

PLANE PRINT

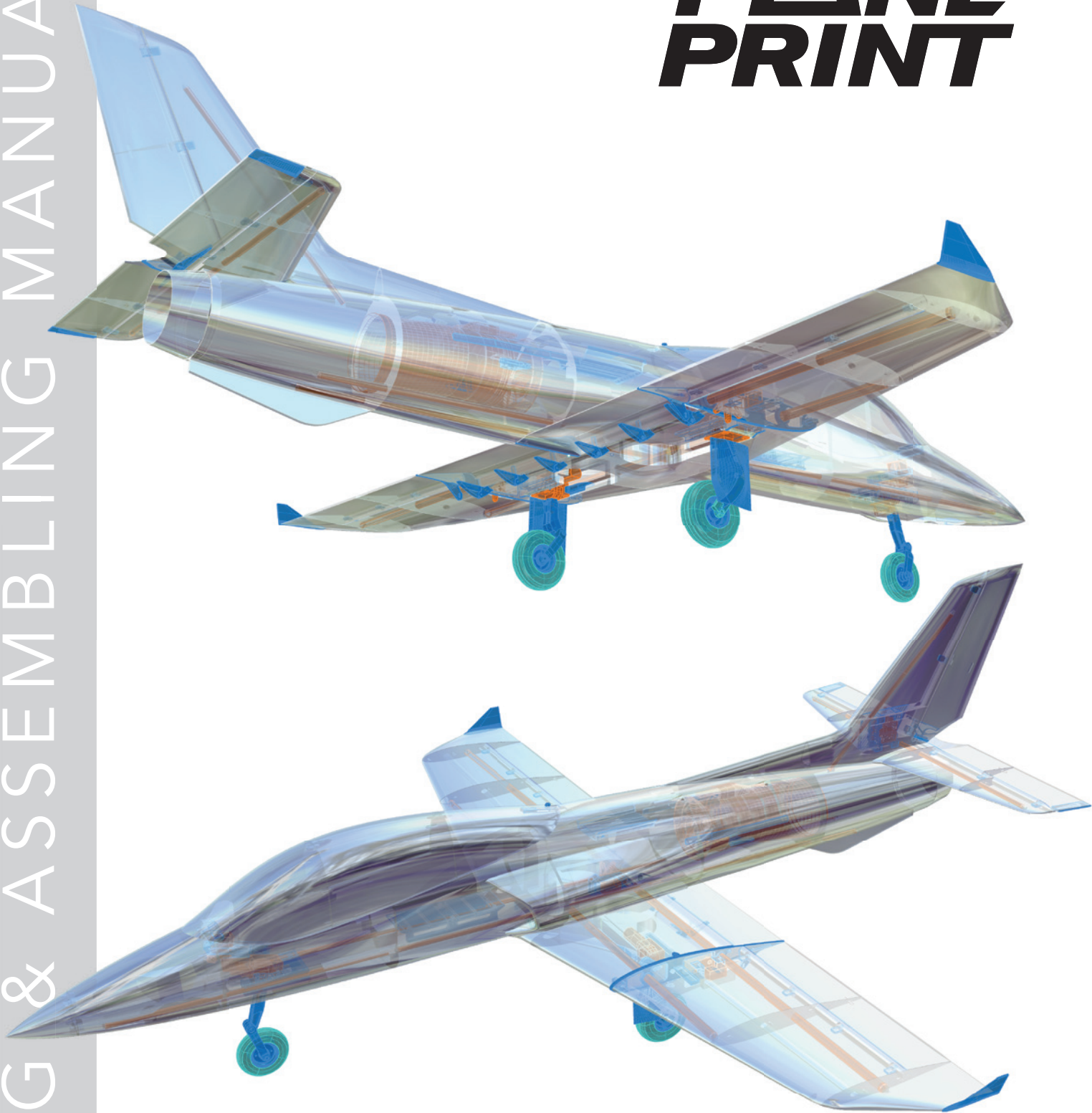

PLANE PRINT **APEX**

3D-printable RC Sports EDF Jet – 70 to 80 mm EDF



www.planepprint.com

the **ONLY** place where you can get original Planeprint STL files **legally!**

© Copyright info:

The design of this aircraft is subject to the copyright of René Marshall and **PLANEPRINT** and may **not** be used or modified for any other purpose.

PLANEPRINT APEX

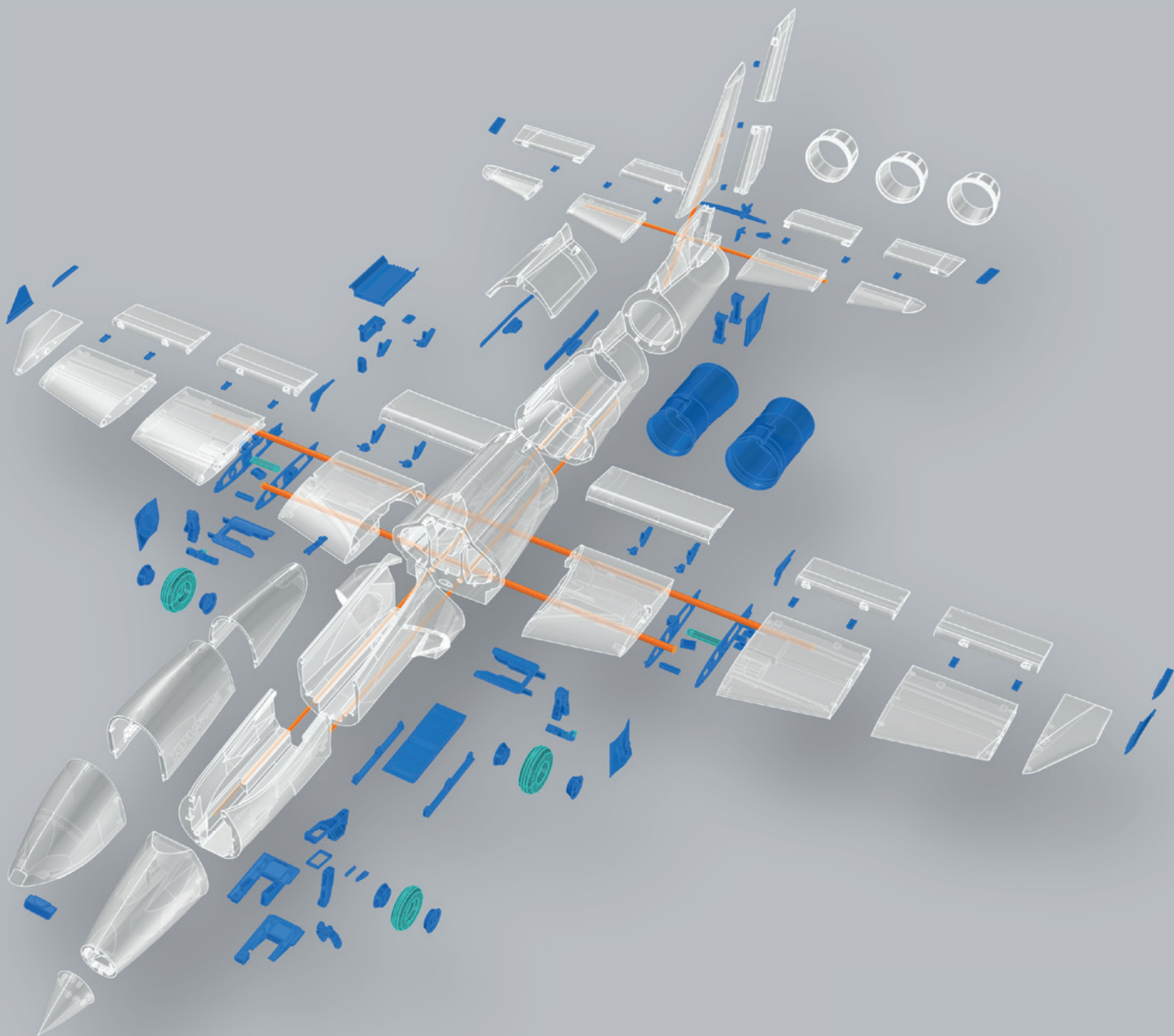

LW-PLA



PLA



TPU



CARBON

RC Components

ENGINE 6S EDF 70 MM – FMS or Wemotec Mini Fan, Stream Fan (We use the FMS)

BEC-CONTROLLER suitable for your EDF (**Make sure to use sufficiently dimensioned plug connections!**)

RECEIVER 8 Channel (2 Ailerons, 1 Flap, 1 Retract, 1 Nose Wheel, 1 Elevator, 1 Rudder, 1 Controller)

BATTERY 6S LiPo Battery, 3000 - 5000 mAh

SERVOS 6 pieces like KST Clubman CM509MG V6 or equivalent (**Metal gears should be preferred**)

Maximum dimensions:

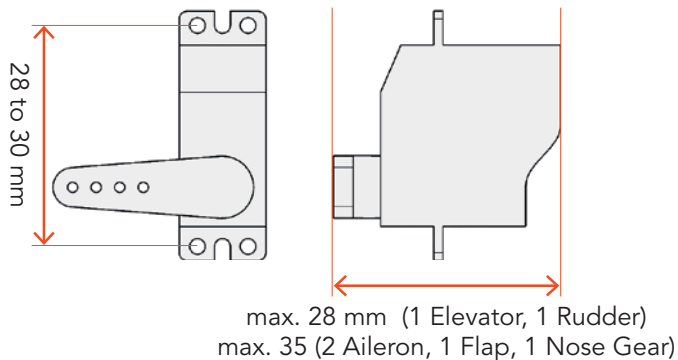

SERVO EXTENSION CABLE 600 mm 2 pieces – Elevator, Rudder
400 mm 4 pieces – main Gear, Ailerons
200 mm 2 pieces – Nose Gear, Nose Wheel
Distribution cable one to three 1 piece – Retract

SERVOLESS RETRACTS Two normal and one steerable Nose Wheel
(we used: 40g Landing Gear, AliExpress – for 3.500g Models)

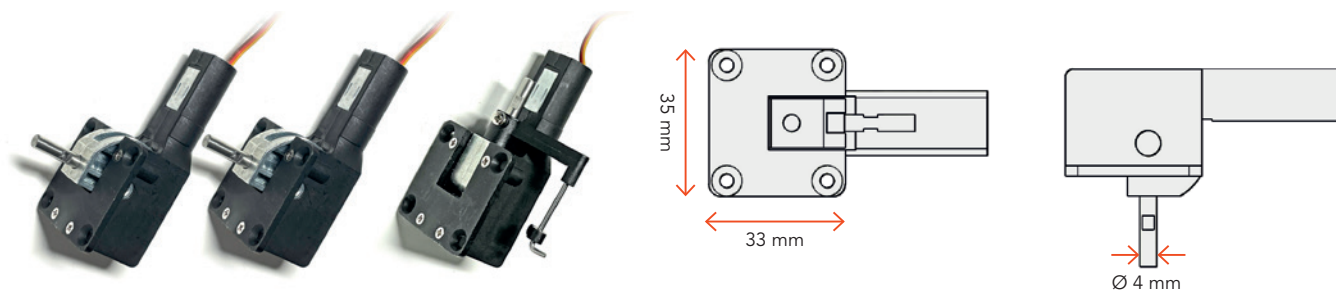

Required accessoires – basic equipment

Links to recommended accessories can be found on www.planeprint.com/apex (scroll down)

- LW-PLA (**cannot be replaced by PLA!**), ~900 grams
- PLA oder better **Tough PLA**, ~220 grams
- LW-TPU Colorfabb VarioShore (A95 possible), ~50 grams

Materials

- CA super glue (liquid and liquid medium)
- CA activator
- some M2 tapping screws
([search for: M2 flat head tapping screw assortment](#))
- some M3 Metal screws
([search for: M3 metal screw assortment](#))
- Metal screw Countersunk head 4*26mm, 1 piece
([can also be replaced with steel wire or a carbon rod](#))
- Metal screw Countersunk head 4*30mm, 2 pieces
([can also be replaced with steel wire or a carbon rod](#))
- Carbon tube Ø10mm*1000mm (inside 8mm), 2 pieces
[Cut the tubes to the following lengths \(mm\): 1000, 678](#)
- Carbon tube Ø6mm*1000mm (inside 4mm), 3 pieces
[Cut the tubes to the following lengths \(mm\): 1000, 805, 430, 259](#)
- Steel wire Ø1*1000mm, 2 pieces
- Rod connection hole Ø1mm, 1 piece
- Threaded inserts M3, 5 pieces ([optional, see description gear](#))
- Neodym-Super-Magnet 5x5x5mm, 4 pieces ([optional](#))
- Ball bearings 4x9x4mm, 6 pieces
- Self-adhesive Velcro tape
- Velcro strap

Tools

Cutter knife, small Philips screwdriver, Sandpaper P150, Metal saw, Needle nose pliers, Soldering tool

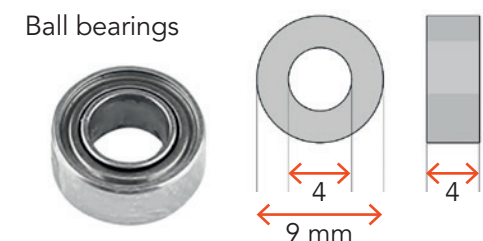
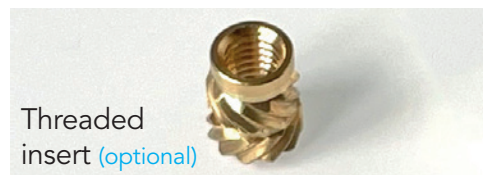
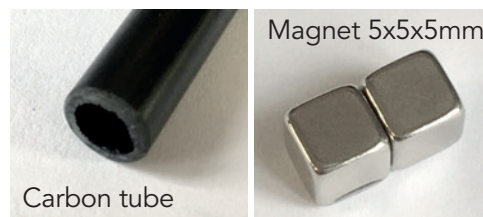



The development of a complex, airworthy RC flight model to express on any standard 3D printer is a very extensive process. **Therefore, we appeal to your fairness not to forward the STL data you have acquired to third parties.**

Thank you for your understanding and have fun with your PLANEPRINT MODEL!

Printing the parts – Printing profiles

This manual is constantly being improved and supplemented, we recommend downloading the **latest version** from our website **before building**.

You can find the description at www.planeprint.com/print

For this model you need the following profiles:



NOTE When printing the PLANEPRINT APEX you should pay particular attention to a light weight of **each** individual part.

PROFILE P5_Gyroid

It is **essential for the necessary stability** of the **LW parts printed with PROFILE_5 are as stable as possible**. Please use a test part to check the strength by fracture tests. It must not break along the layer lines under any circumstances! Also note that the printing temperature for LW-PLA is as low as possible to obtain a wall thickness of 0.4 to 0.6 mm at a flow of 60 to 70 % (depending on brand).

Caution: at too high temperatures, LW-PLA becomes brittle and breaks more easily.

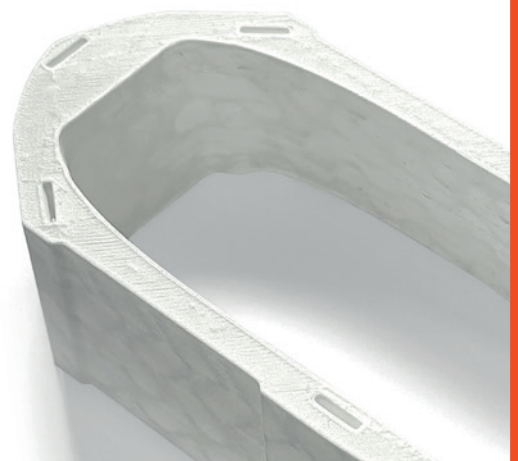

PROFILE P1_Fullbody Tough PLA or PLA



The information about the basic settings you can find on our website at PRINT.
Please note the additional settings for the individual parts!

P1_Controller Mount_ax.stl

MATERIAL PLA, Weight: ~ 10 g

ADDITIONAL SETTINGS

- If it doesn't stick to the print bed, use Brim

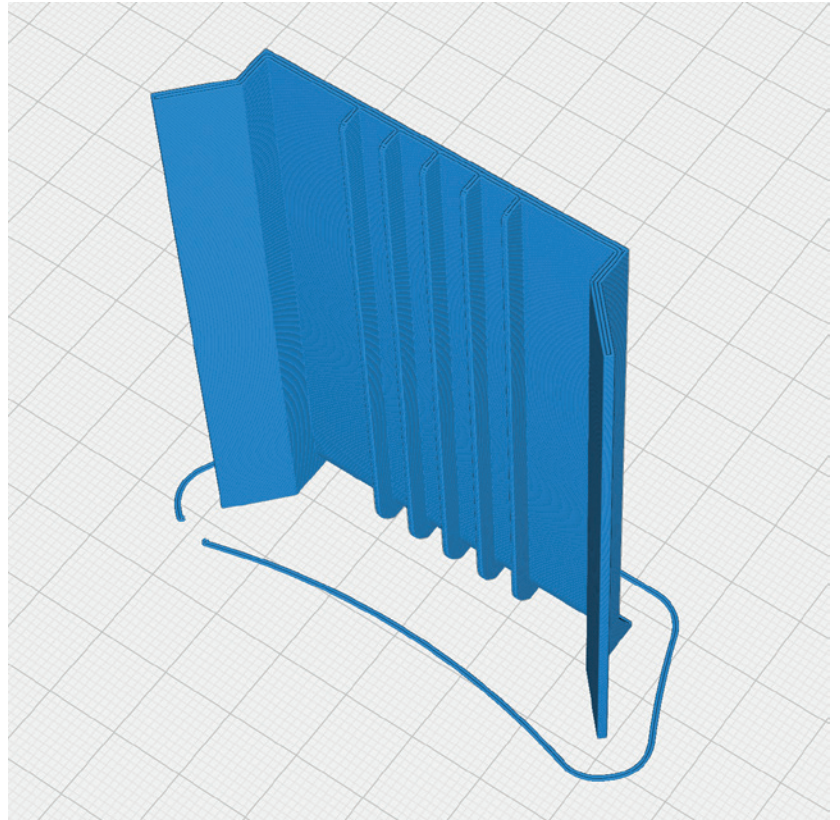

P1_Interconnects_ax.stl

MATERIAL PLA, Weight: ~ 4 g

ADDITIONAL SETTINGS

None required

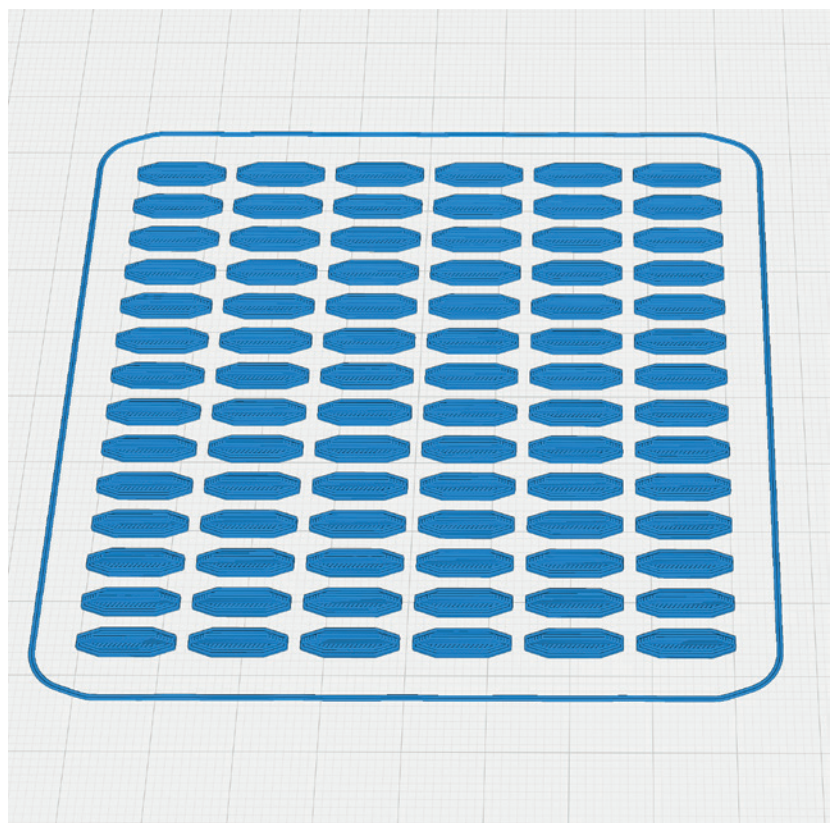

PROFILE P1_Fullbody **Tough PLA or PLA**



The information about the basic settings you can find on our website at PRINT.
Please note the additional settings for the individual parts!

P1_Main Gear_ax.stl

MATERIAL PLA, Weight: ~ 27 g

ADDITIONAL SETTINGS

None required

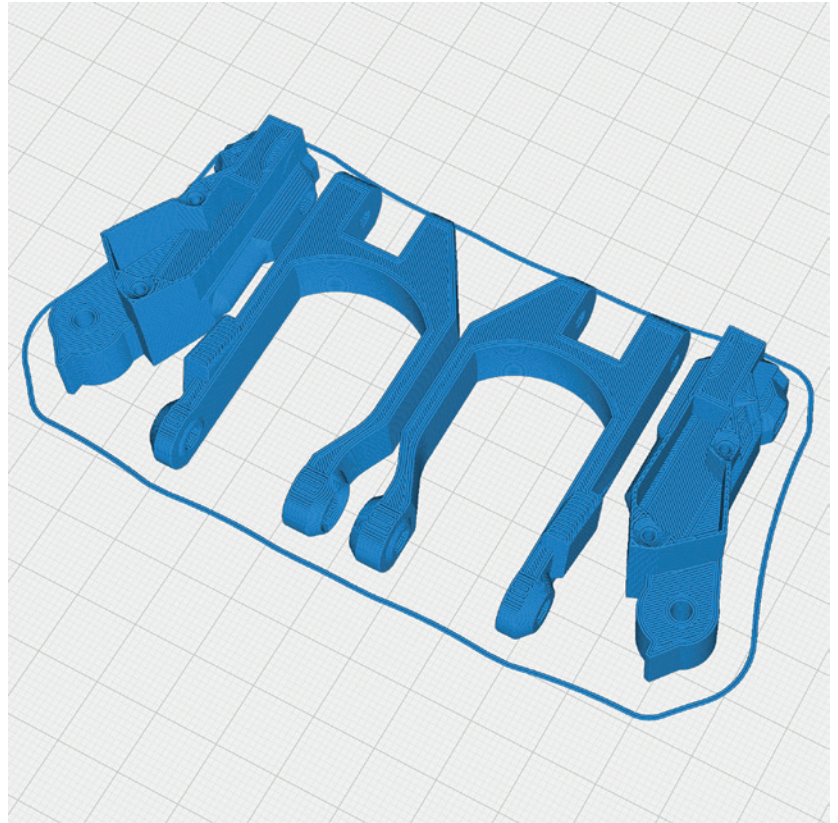

P1_Nose Gear_ax.stl

MATERIAL PLA, Weight: ~ 10 g

ADDITIONAL SETTINGS

None required



PROFILE P1_Fullbody Tough PLA or PLA



The information about the basic settings you can find on our website at PRINT.
Please note the additional settings for the individual parts!

P1_Parts Aileron_ax.stl

MATERIAL PLA, Weight: ~ 6 g

ADDITIONAL SETTINGS

None required



P1_Parts Elevator_ax.stl

MATERIAL PLA, Weight: ~ 6 g

ADDITIONAL SETTINGS

None required

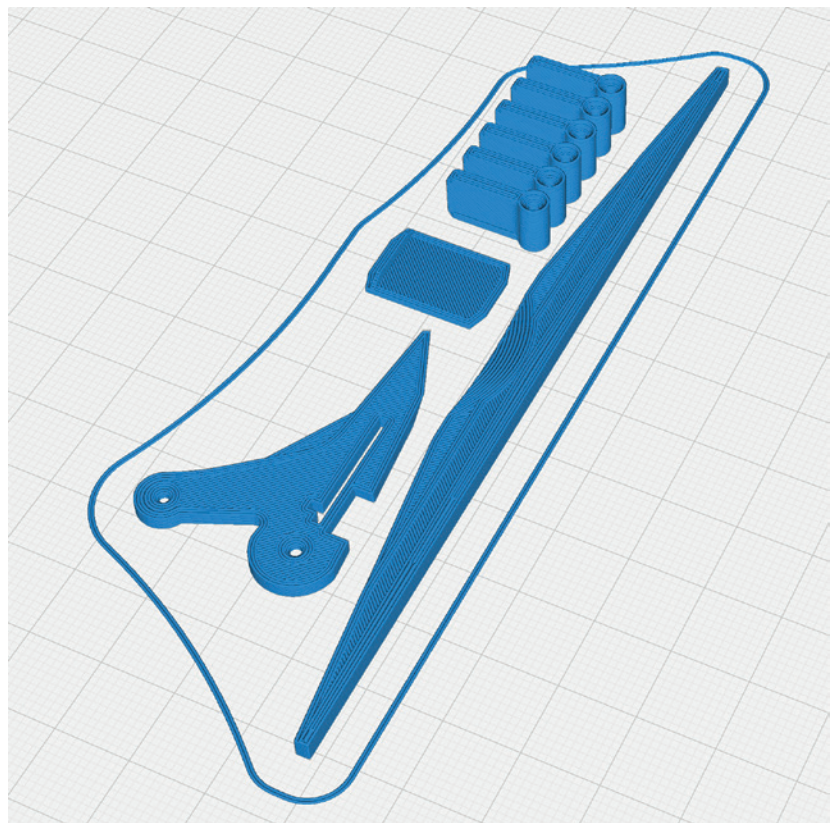

PROFILE P1_Fullbody Tough PLA or PLA



The information about the basic settings you can find on our website at PRINT.
Please note the additional settings for the individual parts!

P1_Parts Rudder_ax.stl

MATERIAL PLA, Weight: ~ 4 g

ADDITIONAL SETTINGS

None required



P1_Parts_ax.stl

MATERIAL PLA, Weight: ~ 11 g

ADDITIONAL SETTINGS

None required

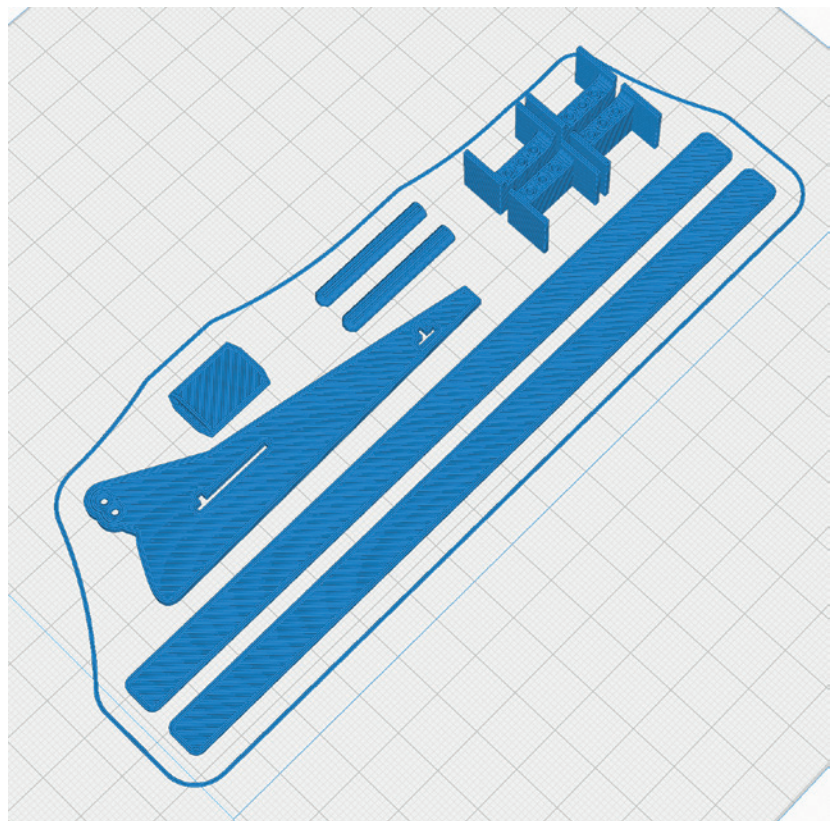

PROFILE P2_Hollowbody Tough PLA or PLA



The information about the basic settings you can find on our website at PRINT.
Please note the additional settings for the individual parts!

P2_Battery Mount_ax.stl

MATERIAL PLA, Weight: ~ 5 g

ADDITIONAL SETTINGS

None required

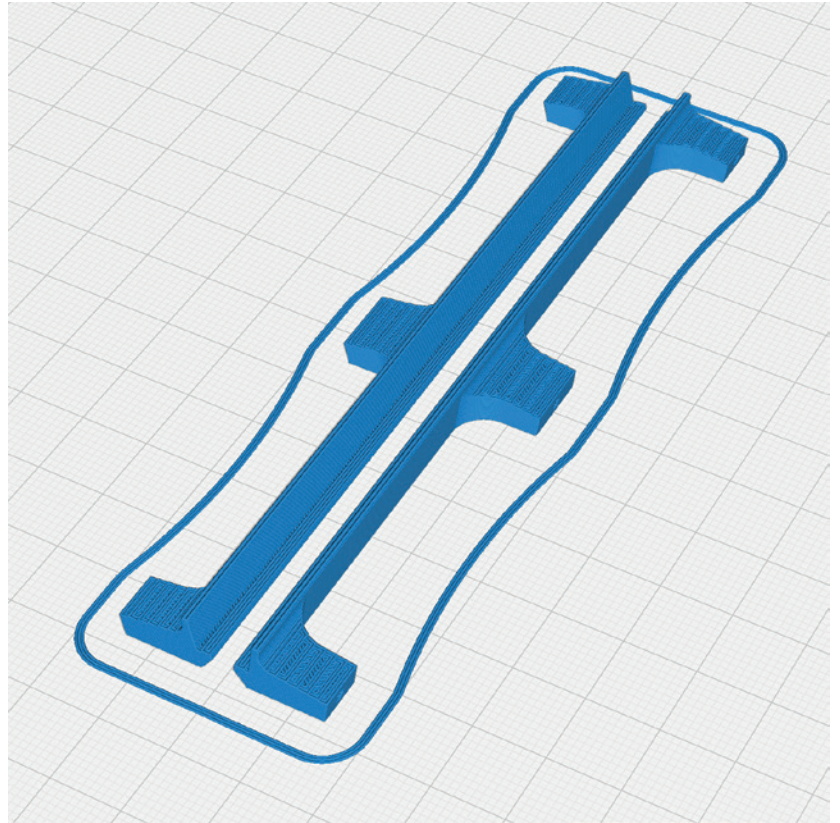

P2_Battery Plate_ax.stl

MATERIAL PLA, Weight: ~ 19 g

ADDITIONAL SETTINGS

- If it doesn't stick to the print bed, use Brim

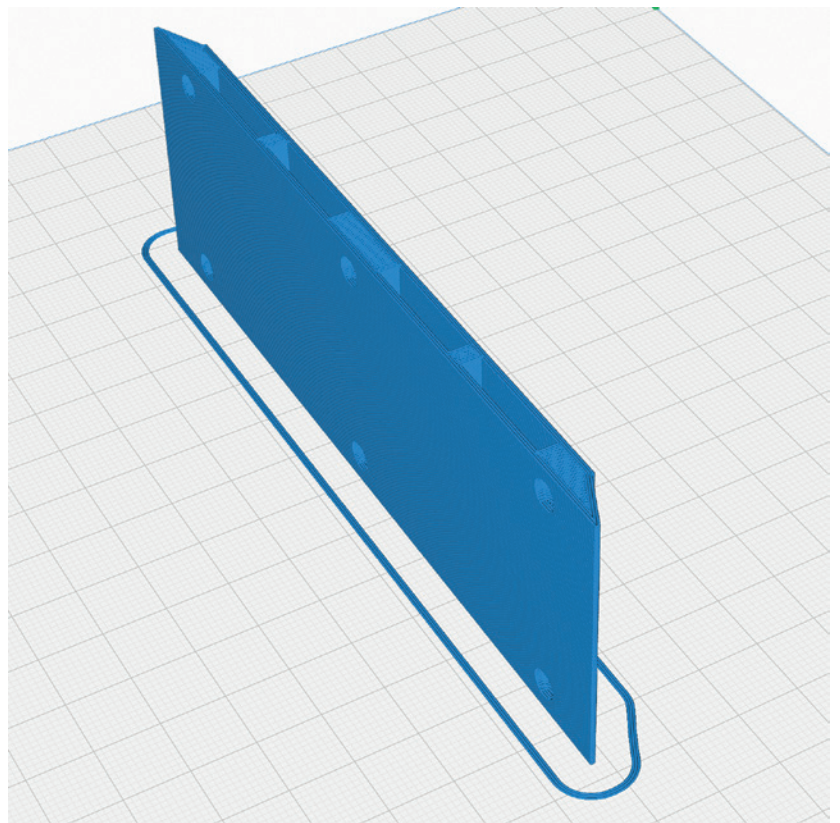

PROFILE P2_Hollowbody Tough PLA or PLA



The information about the basic settings you can find on our website at PRINT.
Please note the additional settings for the individual parts!

P2_EDF Mount 70mm_ax.stl or
P2_EDF Mount 80mm_ax.stl

MATERIAL PLA, Weight: ~ 3 g

ADDITIONAL SETTINGS

None required

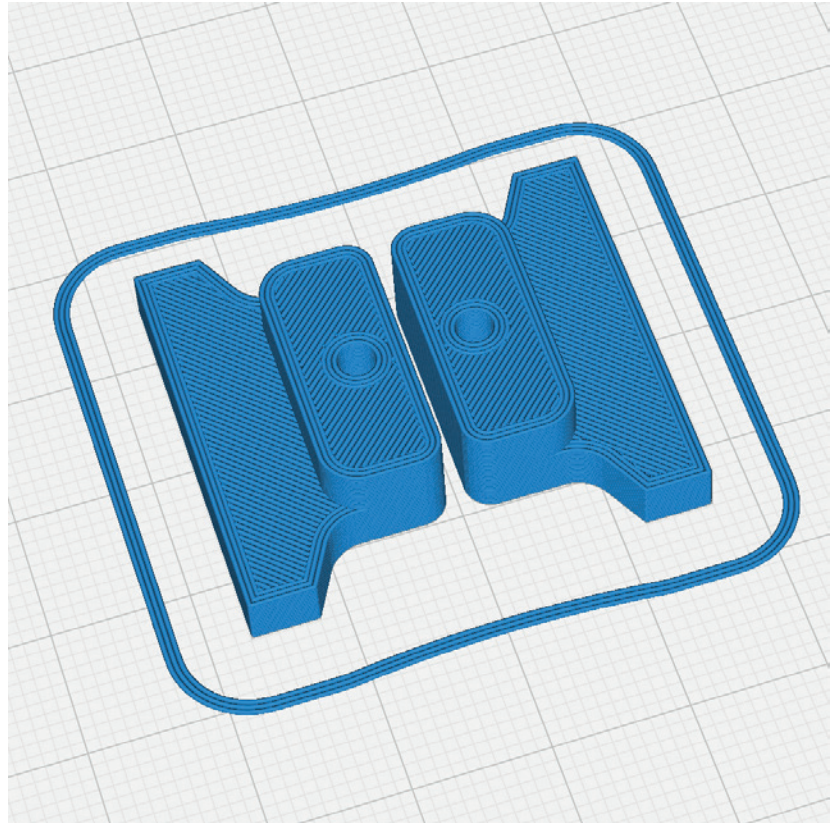

P2_ELE Protectors_ax.stl

MATERIAL PLA, Weight: ~ 2 g

ADDITIONAL SETTINGS

None required

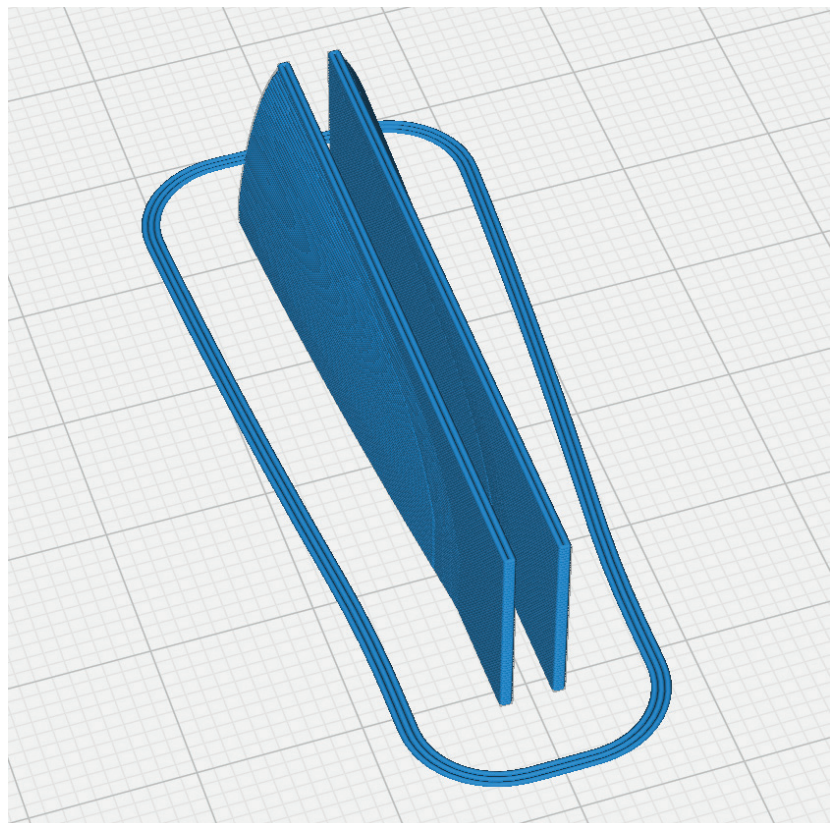

PROFILE P2_Hollowbody Tough PLA or PLA



The information about the basic settings you can find on our website at PRINT.
Please note the additional settings for the individual parts!

P2_Gearmount Nose_ax.stl

MATERIAL PLA, Weight: ~ 19 g

ADDITIONAL SETTINGS

- activate Support

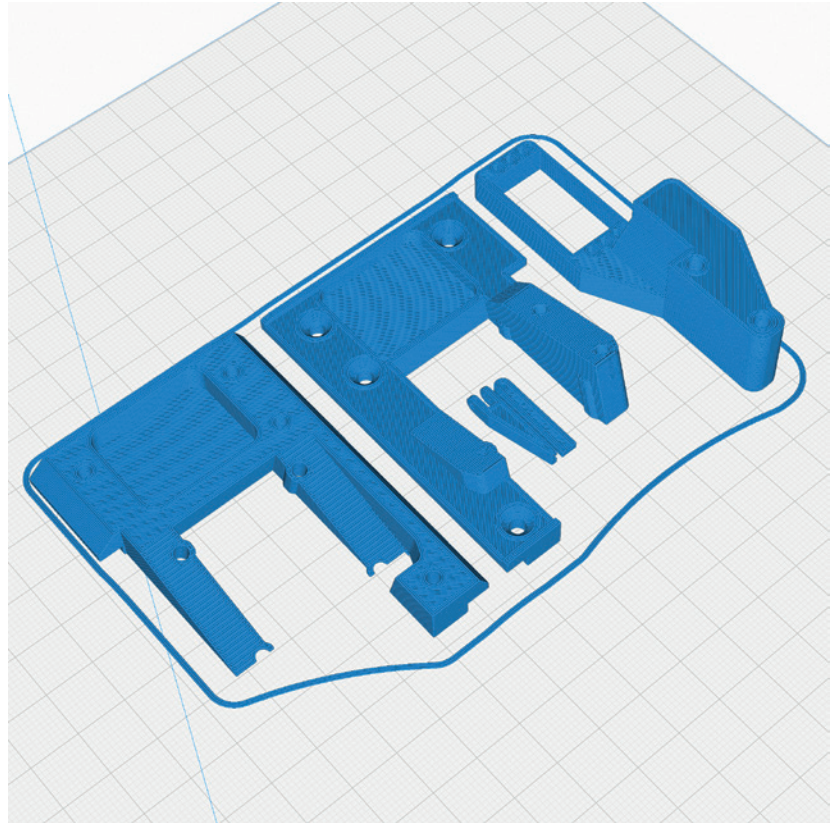

P2_Hinges FLAPS_ax.stl

MATERIAL PLA, Weight: ~ 10 g

ADDITIONAL SETTINGS

None required



PROFILE P2_Hollowbody Tough PLA or PLA



The information about the basic settings you can find on our website at PRINT.
Please note the additional settings for the individual parts!

P2_Main Gear Plates_ax.stl

MATERIAL PLA, Weight: ~ 16 g

ADDITIONAL SETTINGS

- Wall Line Count/Perimeters: 3
- Top/Bottom Layers: 3

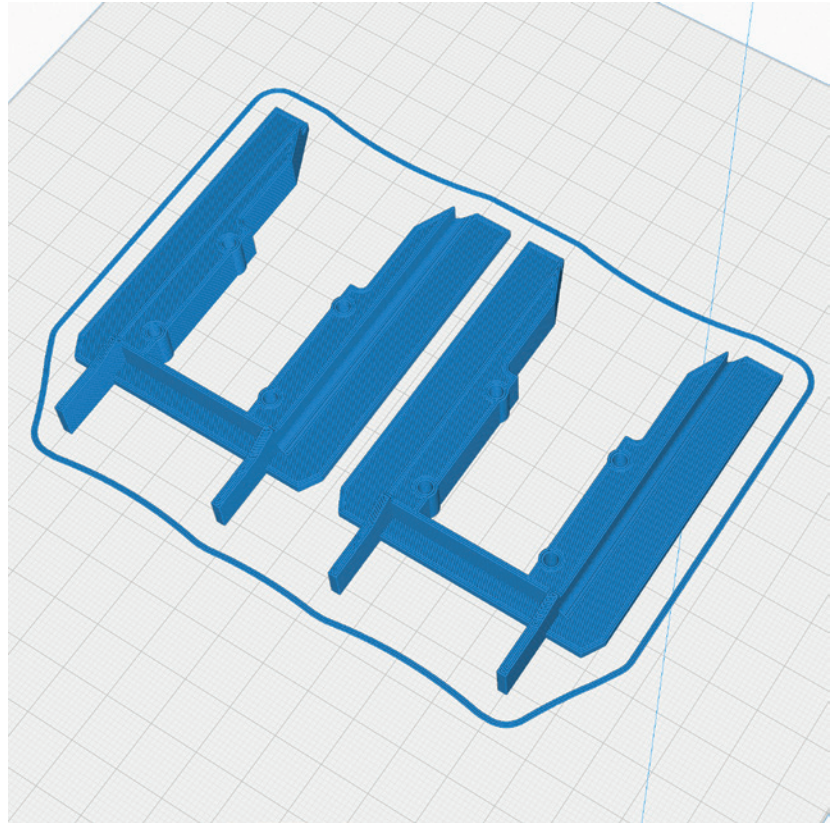

P2_Parts_ax.stl

MATERIAL PLA, Weight: ~ 16 g

ADDITIONAL SETTINGS

None required

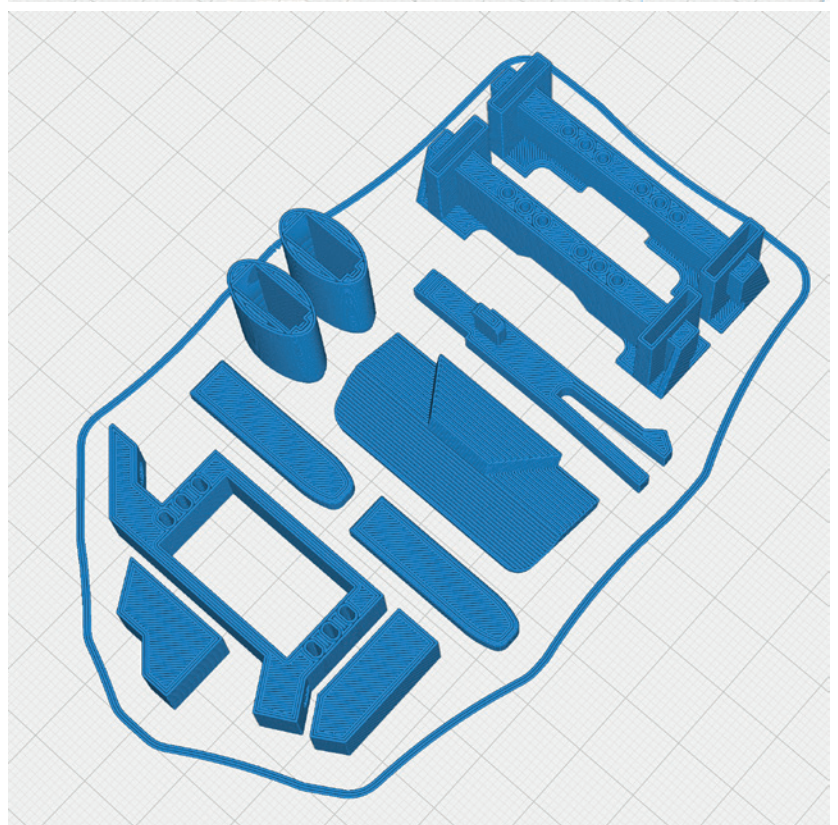

PROFILE P2_Hollowbody Tough PLA or PLA



The information about the basic settings you can find on our website at PRINT.
Please note the additional settings for the individual parts!

P2_Protectors Fuselage_ax.stl

MATERIAL PLA, Weight: ~ 9 g

ADDITIONAL SETTINGS

None required

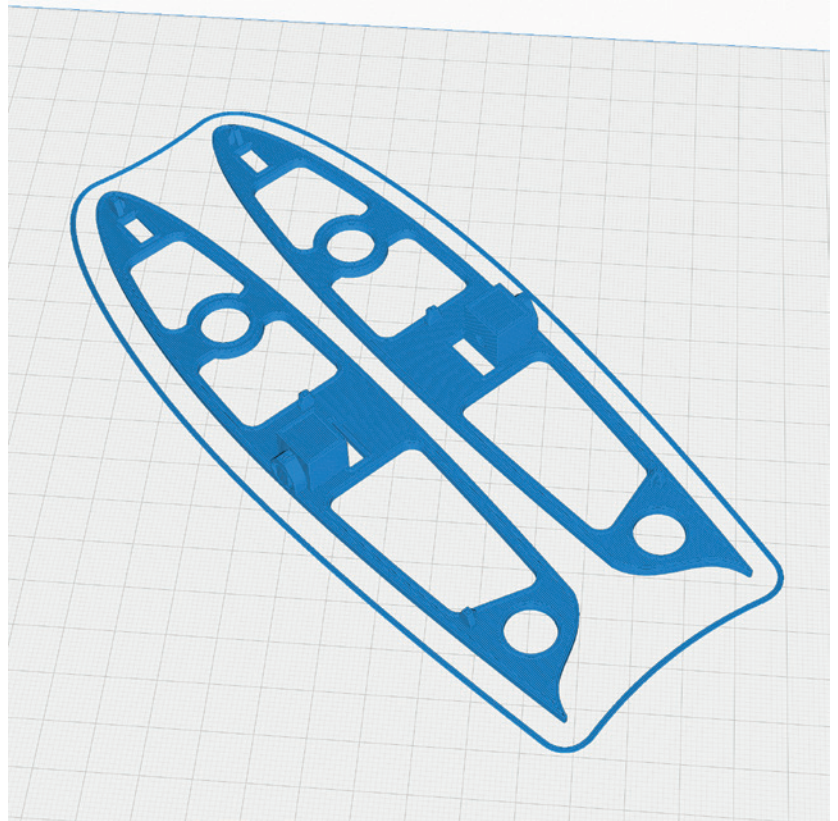

P2_Protectors Wing_ax.stl

MATERIAL PLA, Weight: ~ 9 g

ADDITIONAL SETTINGS

None required

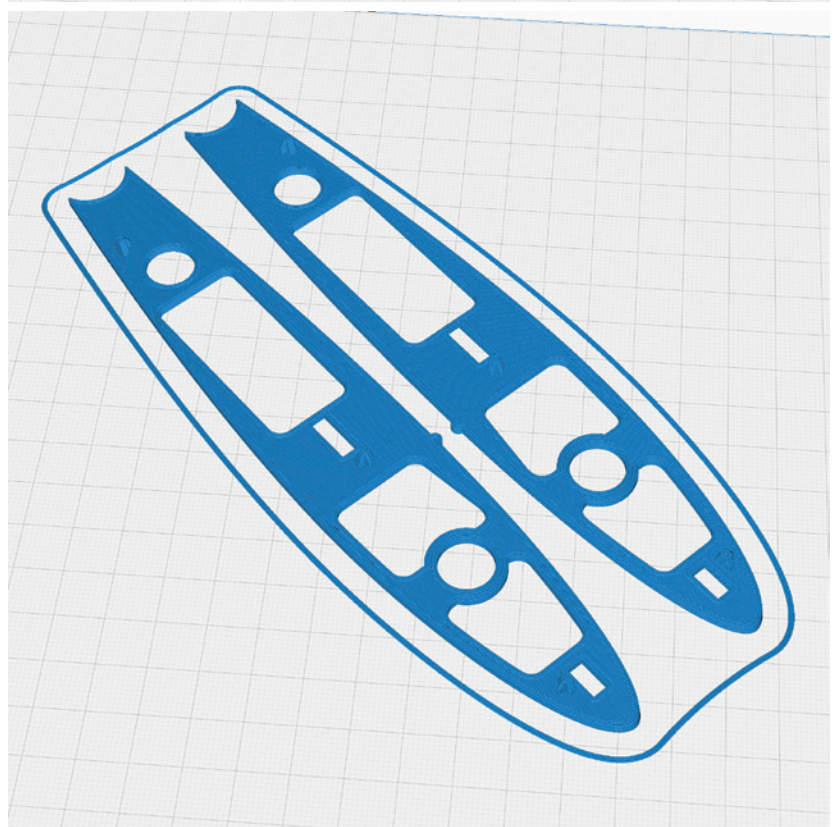

PROFILE P2_Hollowbody Tough PLA or PLA



The information about the basic settings you can find on our website at PRINT.
Please note the additional settings for the individual parts!

P2_Rim main_ax.stl

MATERIAL PLA, Weight: ~ 6 g

ADDITIONAL SETTINGS

- print twice

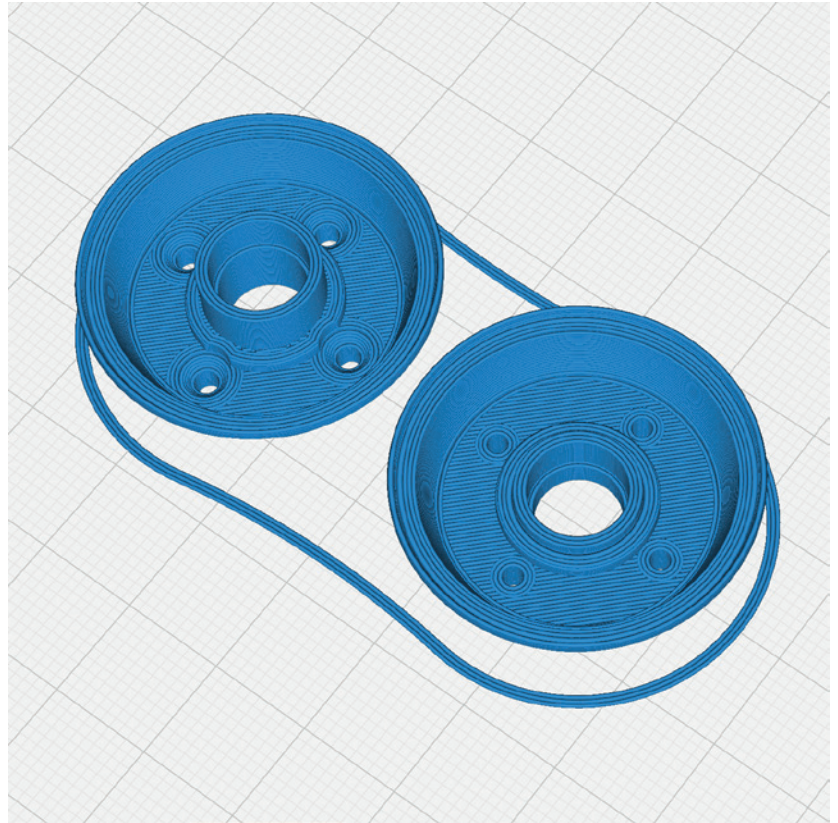

P2_Rim nose_ax.stl

MATERIAL PLA, Weight: ~ 5 g

ADDITIONAL SETTINGS

None required

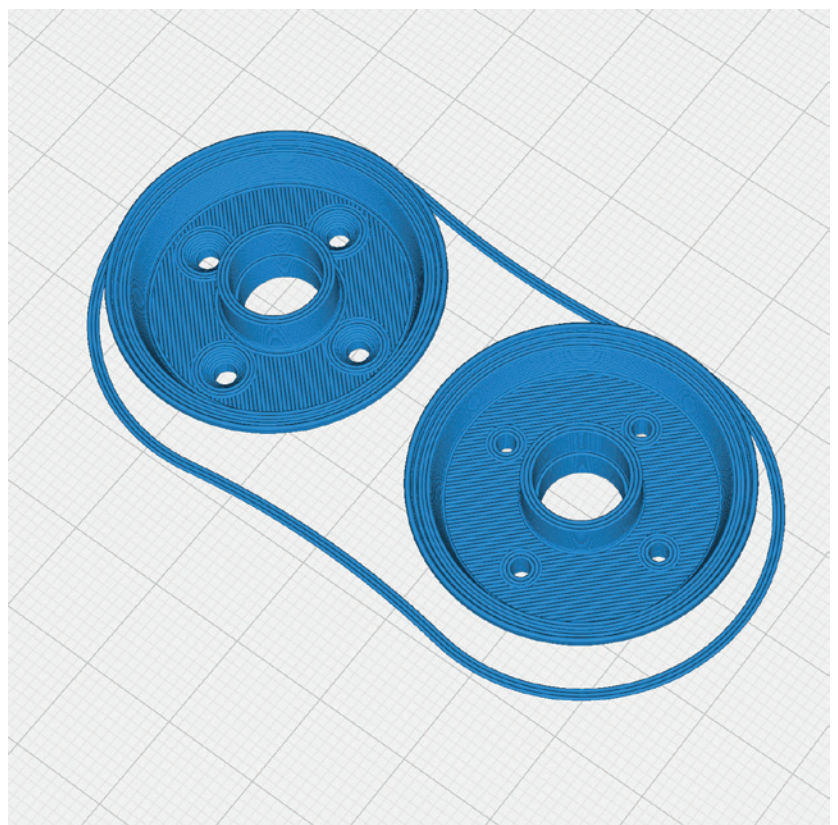

PROFILE P2_Hollowbody Tough PLA or PLA



The information about the basic settings you can find on our website at PRINT.
Please note the additional settings for the individual parts!

P2_Servomount Tail_ax.stl

MATERIAL PLA, Weight: ~ 5 g

ADDITIONAL SETTINGS

None required

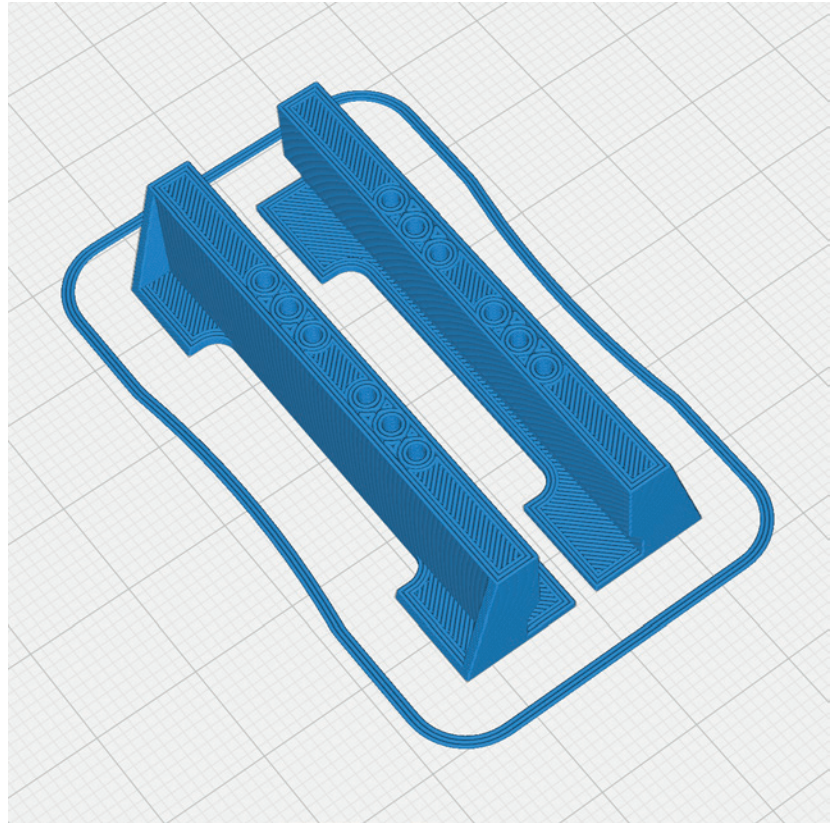

P2_Winglets_ax.stl or P2_Wingtips_ax.stl

MATERIAL PLA, Weight: ~ 5 g

ADDITIONAL SETTINGS

- Wall Line Count/Perimeters: 1
- Infill Density: 8 %
- Seam Gap Distance: -1mm
- set Brim

You can choose between wingtips and winglets

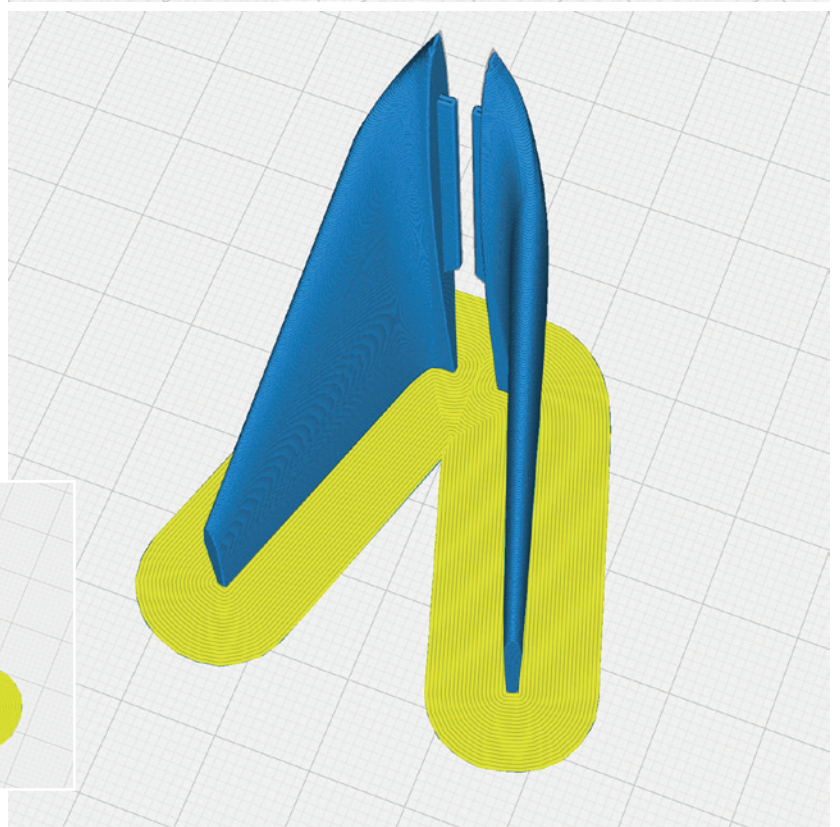

SPIRALIZE/VASE MODE – Tough PLA or PLA

The following parts must be sliced with the Funktion **Spiralize Outer Contour** (Cura) or **Spiral Vase** (Prusa Slicer). For these parts, only the outer wall (1 line/perimeter) is printed without Z-seam, no top layers.

V_Gear Covers_ax.stl

MATERIAL PLA, ~ 6 g

SETTINGS

- Wall Line Count/Perimeters: 1
- Spiralize Outer Contour (Cura)/
Spiral Vase (Prusa)
- Top/Bottom Layers: 0
- Brim

TIP If the walls of your print are too thin, you can increase the wall thickness (to 0.5).

Remove the yellow-marked support with a pair of scissors

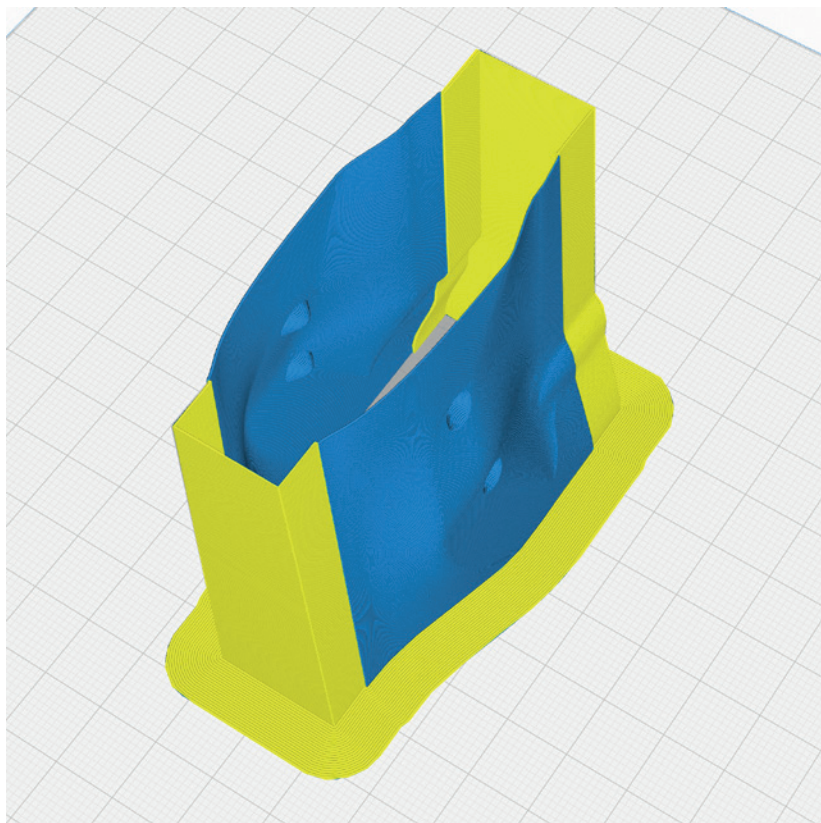

V_Tube FMS70mm_ax.stl or V_Tube FMS80mm_ax.stl

MATERIAL PLA, ~ 6 g

SETTINGS

- Wall Line Count/Perimeters: 1
- Spiralize Outer Contour (Cura)/
Spiral Vase (Prusa)
- Top/Bottom Layers: 0
- Brim

TIP If the walls of your print are too thin, you can increase the wall thickness (to 0.5).

Remove the yellow-marked support

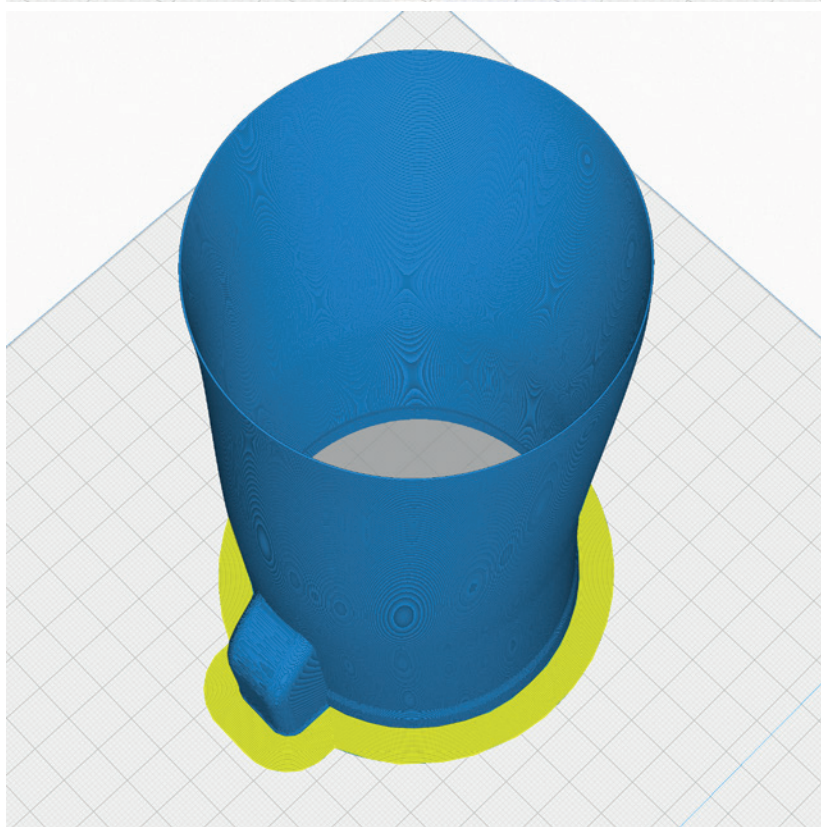

PROFILE P4_Flex LW TPU (A95/VarioShore)



The information about the basic settings you can find on our website at PRINT.
Please note the additional settings for the individual parts!

P4_Tire main_ax.stl

MATERIAL VarioShore or TPU A95

ADDITIONAL SETTINGS

- Print this twice

VarioShore with Flow 70 %:

- Wall Line Count/Perimeters: 5
- Top Layers: 5
- Bottom Layers: 5
- Infill Density: 10 %
- Infill Pattern: Gyroid

TPU A95:

- Wall Line Count: 3
- Top Layers: 3
- Infill Density: 6 %
- Infill Pattern: Gyroid

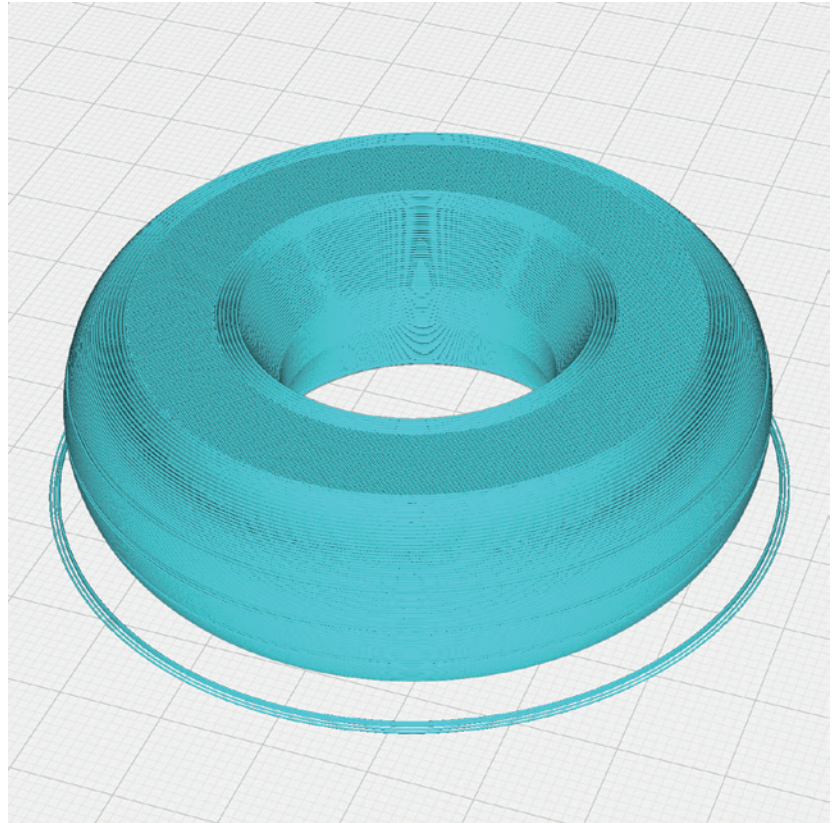

P4_Tire nose_ax.stl

MATERIAL VarioShore or TPU A95

ADDITIONAL SETTINGS

VarioShore with Flow 70 %:

- Wall Line Count/Perimeters: 5
- Top Layers: 5
- Bottom Layers: 5
- Infill Density: 10 %
- Infill Pattern: Gyroid

TPU A95:

- Wall Line Count: 3
- Top Layers: 3
- Infill Density: 6 %
- Infill Pattern: Gyroid

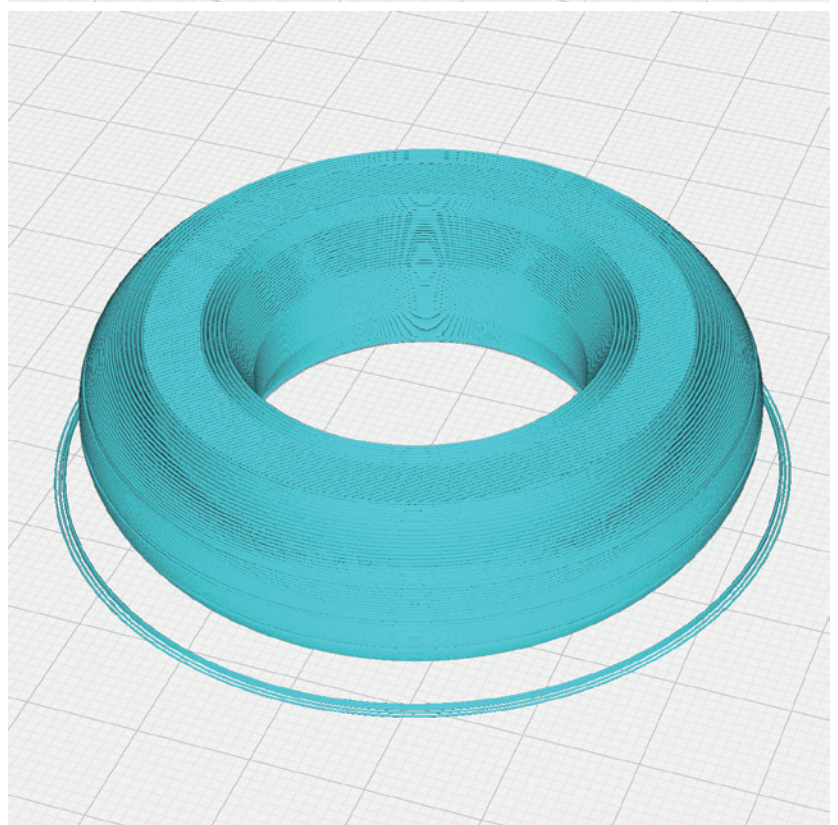

PROFILE P4_Flex LW TPU (A95/VarioShore)



The information about the basic settings you can find on our website at PRINT.
Please note the additional settings for the individual parts!

P4_Wingmount_ax.stl

MATERIAL TPU, Weight: ~ 3 g

ADDITIONAL SETTINGS

- Wall Line Count/Perimeters: 10

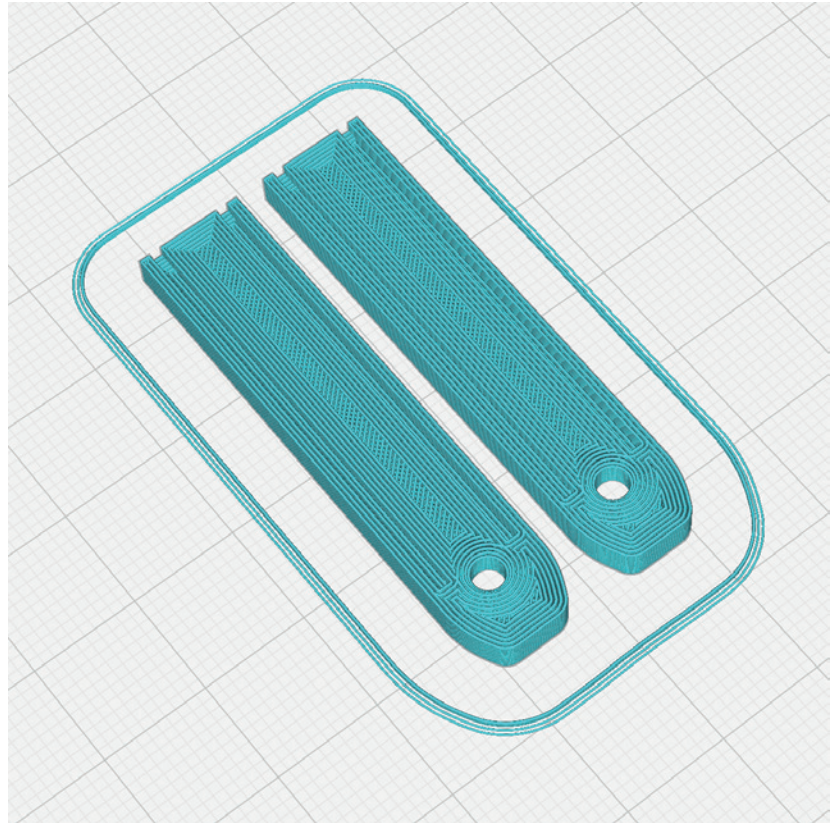

PROFILE P5_Gyroid LW-PLA (foaming)!



The information about the basic settings you can find on our website at PRINT.

Please note the additional settings for the individual parts!

It is essential to print these parts with foaming LW-PLA (pre-foamed is heavier)!

Basic settings for LW-PLA: Please follow the instructions in our **WINGTEST AND CALIBRATION TOOL** on our website for correct adjustment! Print only one STL at a time!

P5_Aileron L_ax.stl and P5_Aileron R_ax.stl

MATERIAL LW PLA, Weight: ~ 19 g

TIME ~ 2 hours 30 minutes

ADDITIONAL SETTINGS

Individual STL files are also available for this part (in the OPTIONAL PARTS folder)

Remove the support marked in yellow using a sharp knife and sandpaper (**please be careful with the knife**)

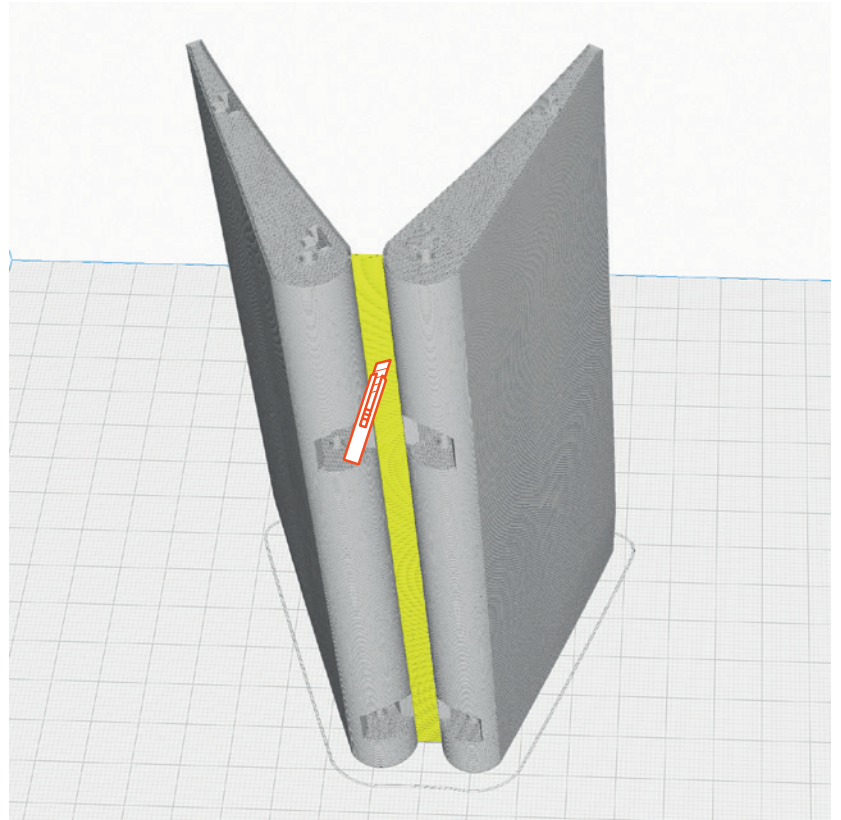
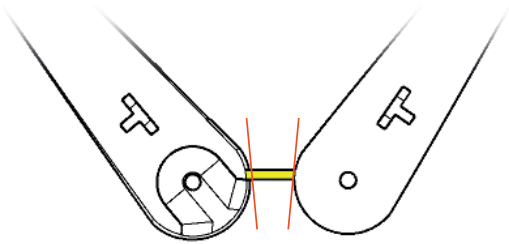

P5_Canopy 1_ax.stl

MATERIAL LW PLA, Weight: ~ 20 g

TIME ~ 2 hours 10 minutes

ADDITIONAL SETTINGS

None required

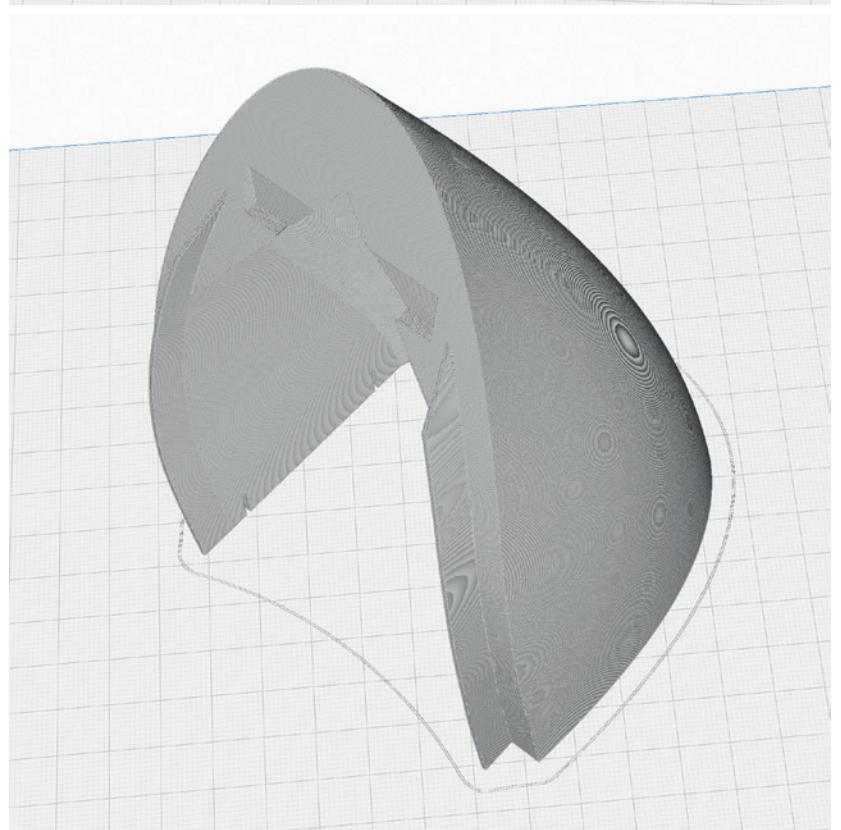

PROFILE P5_Gyroid LW-PLA (foaming)!



The information about the basic settings you can find on our website at PRINT.

Please note the additional settings for the individual parts!

It is essential to print these parts with foaming LW-PLA (pre-foamed is heavier)!

Basic settings for LW-PLA: Please follow the instructions in our **WINGTEST AND CALIBRATION TOOL** on our website for correct adjustment! Print only one STL at a time!

P5_Canopy 2_ax.stl

MATERIAL LW PLA, Weight: ~ 24 g

TIME ~ 3 hours

ADDITIONAL SETTINGS

None required

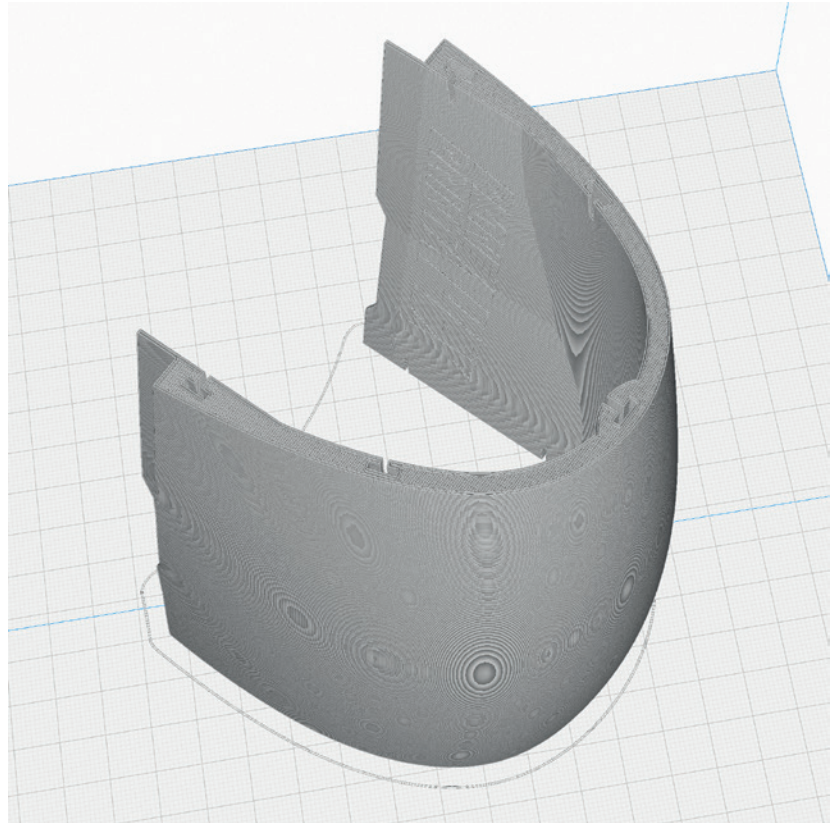

P5_Canopy 3_ax.stl

MATERIAL LW PLA, Weight: ~ 14 g

TIME ~ 1 hour 40 minutes

ADDITIONAL SETTINGS

None required

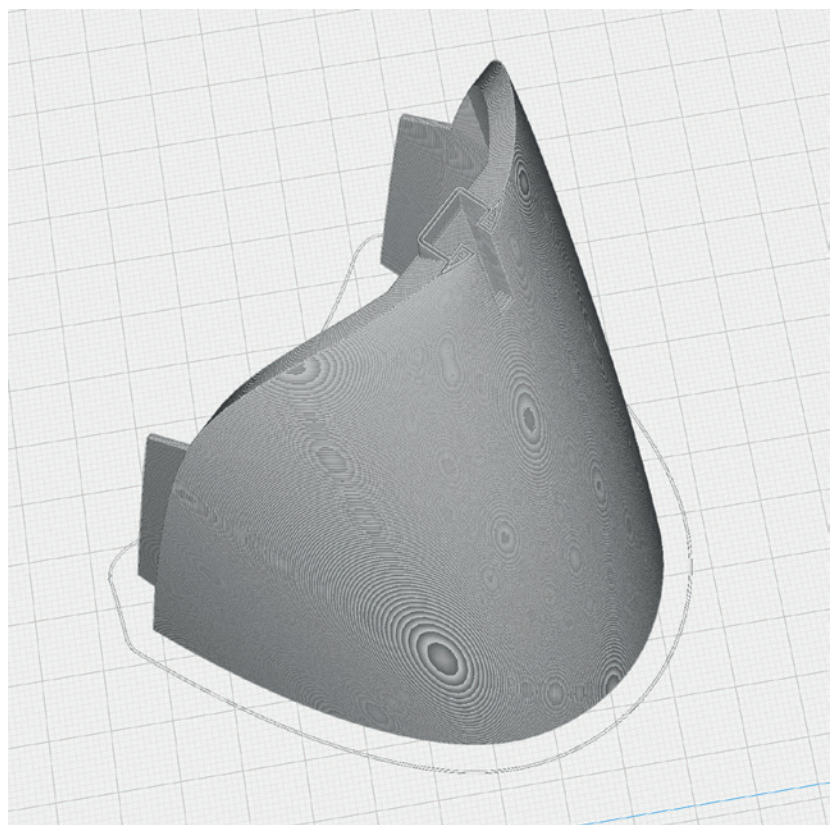

PROFILE P5_Gyroid LW-PLA (foaming)!



The information about the basic settings you can find on our website at PRINT.

Please note the additional settings for the individual parts!

It is essential to print these parts with foaming LW-PLA (pre-foamed is heavier)!

Basic settings for LW-PLA: Please follow the instructions in our **WINGTEST AND CALIBRATION TOOL** on our website for correct adjustment! Print only one STL at a time!

P5_EDF Cover_ax.stl

MATERIAL LW PLA, Weight: ~ 18 g

TIME ~ 2 hours

ADDITIONAL SETTINGS

None required

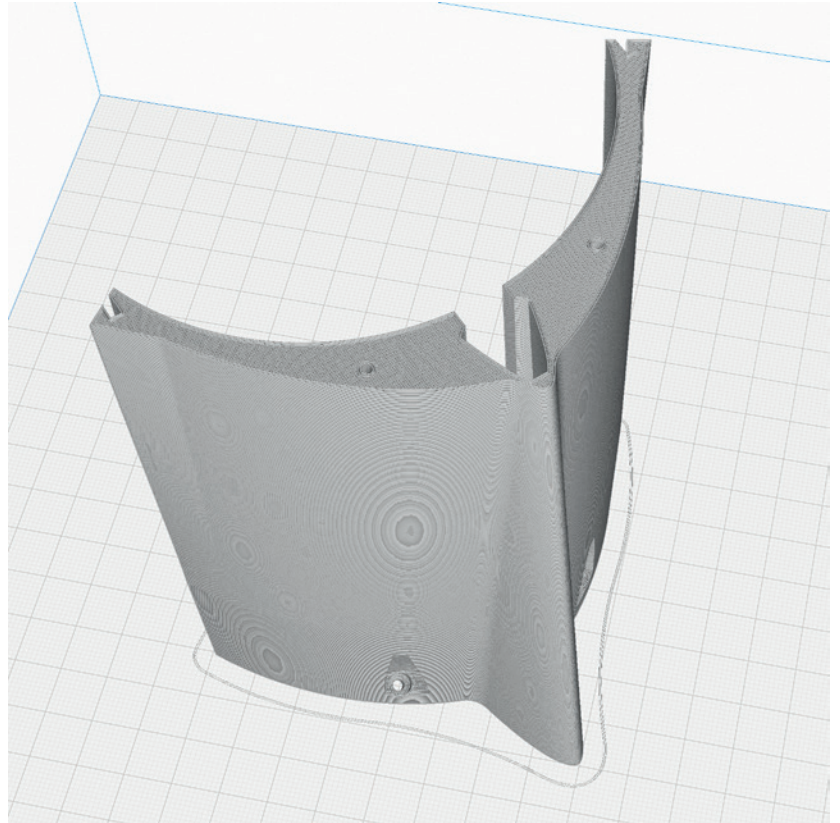

P5_Elevator L_ax.stl and P5_Elevator R_ax.stl

MATERIAL LW PLA, Weight: ~ 14 g

TIME ~ 1 hour 40 minutes

ADDITIONAL SETTINGS

Individual STL files are also available for this part (in the OPTIONAL PARTS folder)

Remove the support marked in yellow using a sharp knife and sandpaper (**please be careful with the knife**)

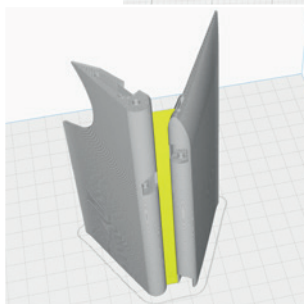
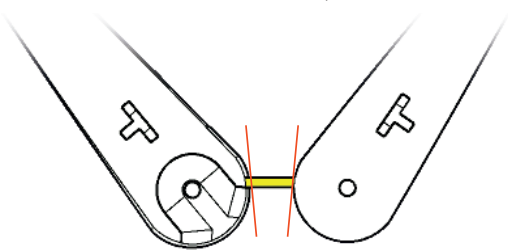
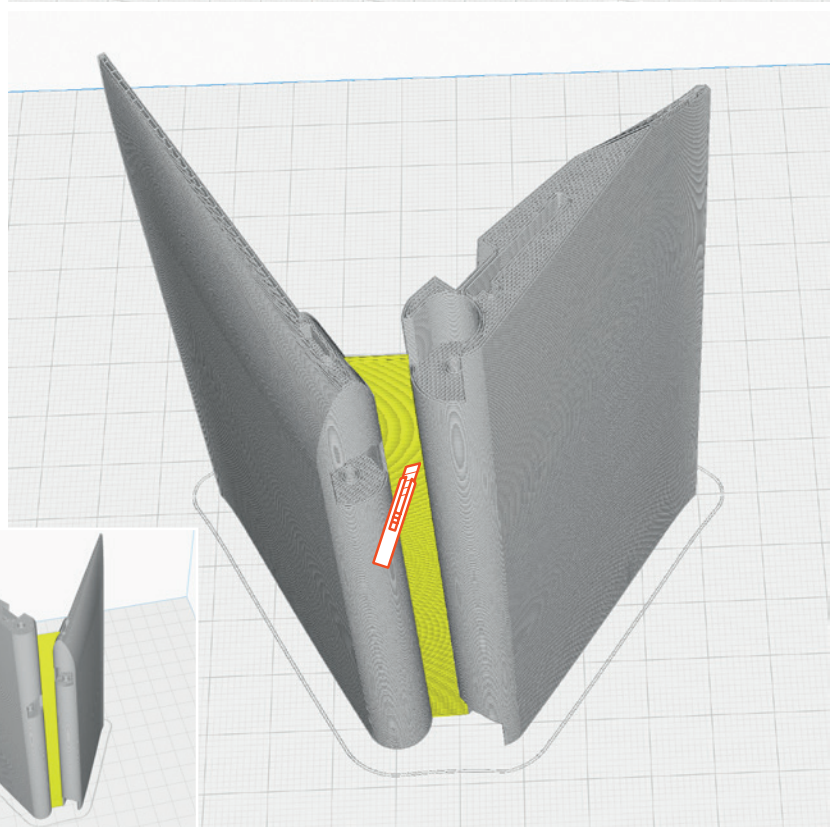

PROFILE P5_Gyroid LW-PLA (foaming)!



The information about the basic settings you can find on our website at PRINT.

Please note the additional settings for the individual parts!

It is essential to print these parts with foaming LW-PLA (pre-foamed is heavier)!

Basic settings for LW-PLA: Please follow the instructions in our **WINGTEST AND CALIBRATION TOOL** on our website for correct adjustment! Print only one STL at a time!

P5_Exhaust Nozzle XX*mm_ax.stl

MATERIAL LW PLA, Weight: ~ 7 g

TIME ~ 50 minutes

ADDITIONAL SETTINGS

None required

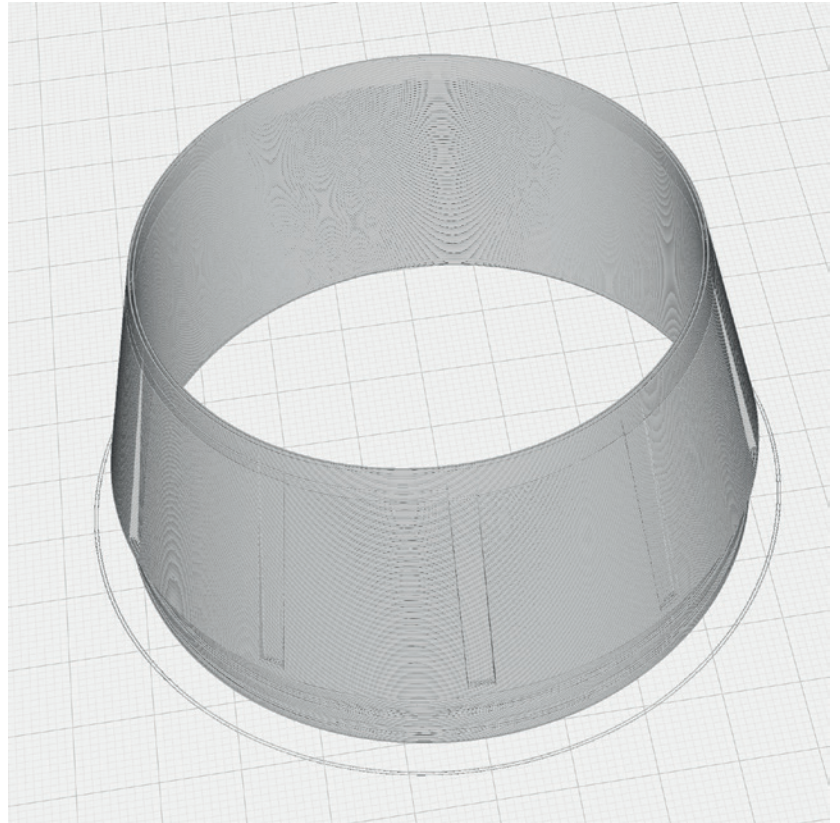

[*See page 44](#)

P5_Flaps_ax.stl

MATERIAL LW PLA, Weight: ~ 32 g

TIME ~ 3 hours 50 minutes

ADDITIONAL SETTINGS

Individual STL files are also available for this part (in the OPTIONAL PARTS folder)

Remove the support marked in yellow using a sharp knife and sandpaper (**please be careful with the knife**)

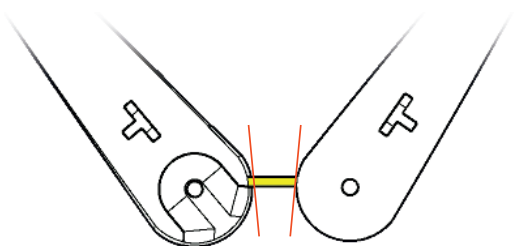
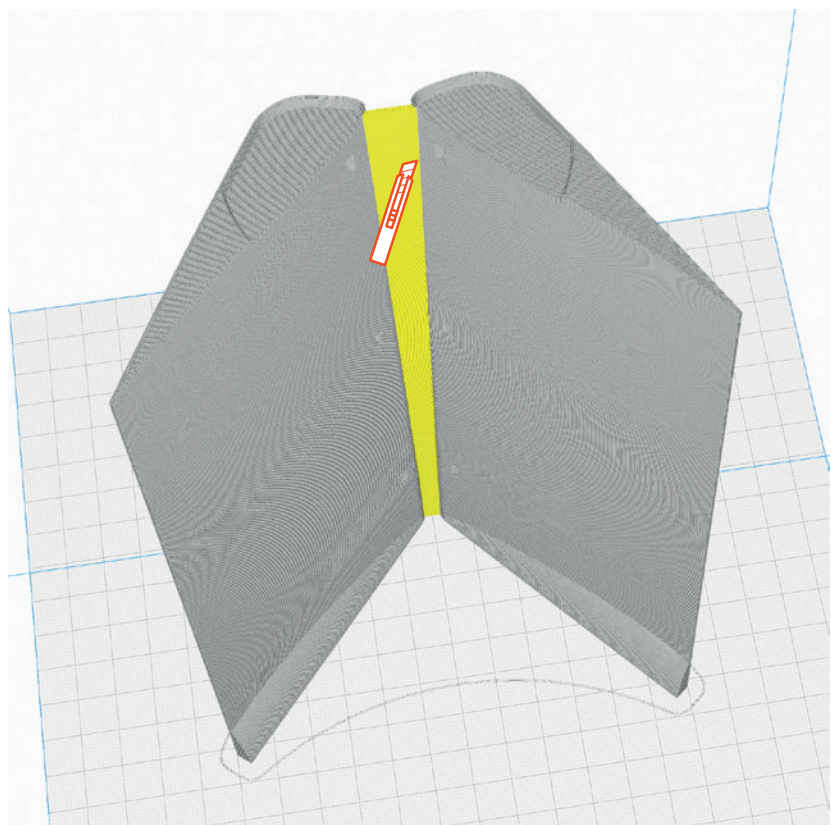

PROFILE P5_Gyroid LW-PLA (foaming)!



The information about the basic settings you can find on our website at PRINT.

Please note the additional settings for the individual parts!

It is essential to print these parts with foaming LW-PLA (pre-foamed is heavier)!

Basic settings for LW-PLA: Please follow the instructions in our **WINGTEST AND CALIBRATION TOOL** on our website for correct adjustment! Print only one STL at a time!

P5_FUS 1_ax.stl

MATERIAL LW PLA, Weight: ~ 33 g

TIME ~ 4 hours

ADDITIONAL SETTINGS

- use Brim

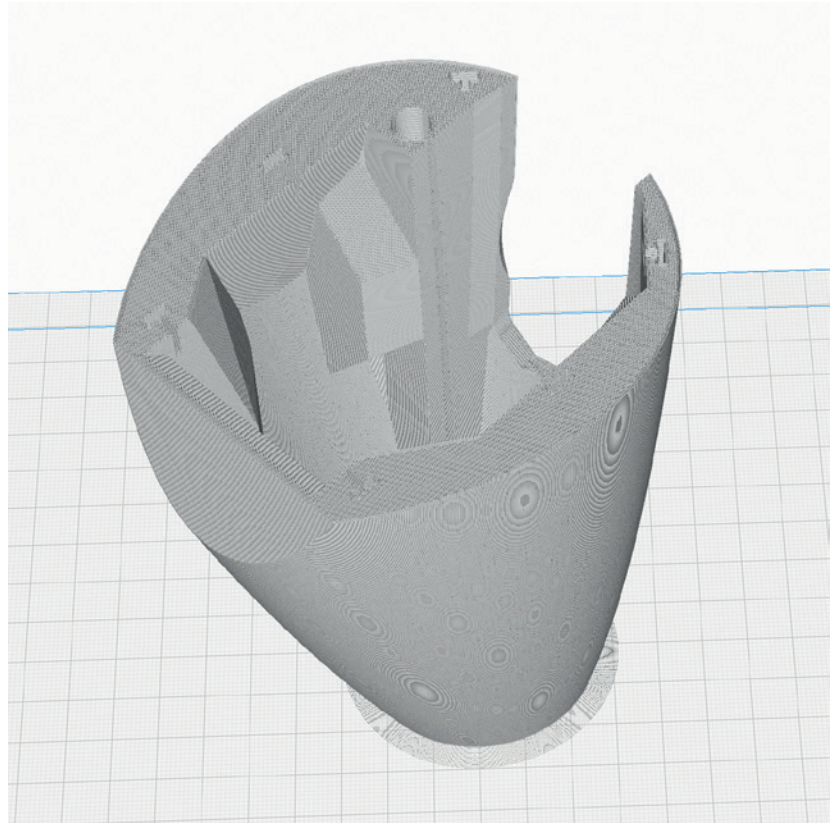

P5_FUS 2_ax.stl

MATERIAL LW PLA, Weight: ~ 45 g

TIME ~ 5 hours 30 minutes

ADDITIONAL SETTINGS

None required

Remove the support marked in yellow using a sharp knife and sandpaper (**please be careful with the knife**)

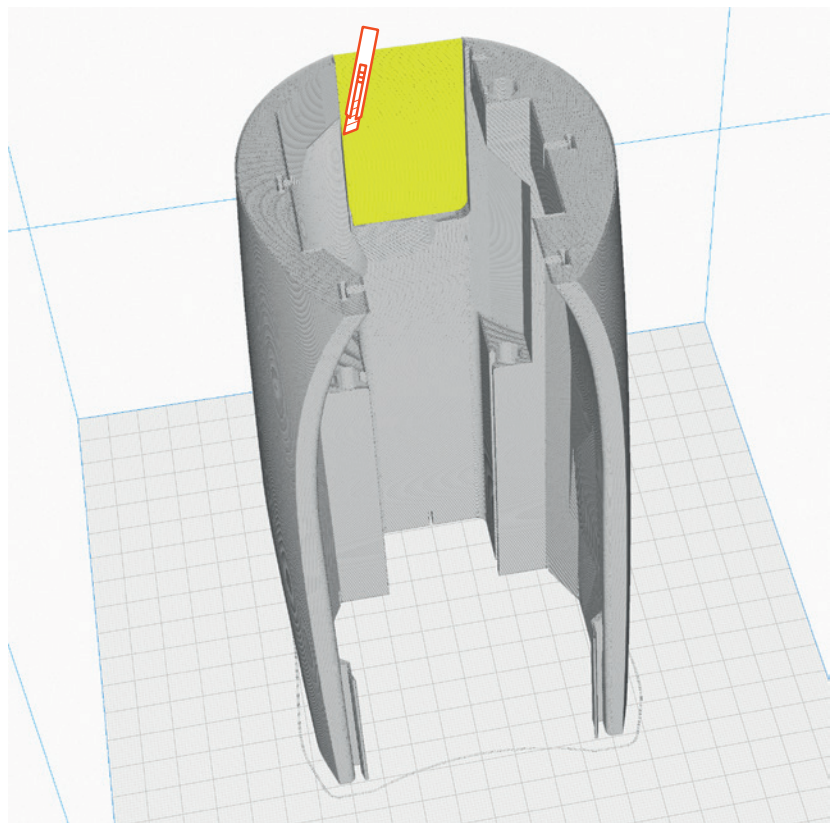

PROFILE P5_Gyroid LW-PLA (foaming)!



The information about the basic settings you can find on our website at PRINT.

Please note the additional settings for the individual parts!

It is essential to print these parts with foaming LW-PLA (pre-foamed is heavier)!

Basic settings for LW-PLA: Please follow the instructions in our **WINGTEST AND CALIBRATION TOOL** on our website for correct adjustment! Print only one STL at a time!

P5_FUS 3_ax.stl

MATERIAL LW PLA, Weight: ~ 67 g

TIME ~ 8 hours

ADDITIONAL SETTINGS

None required

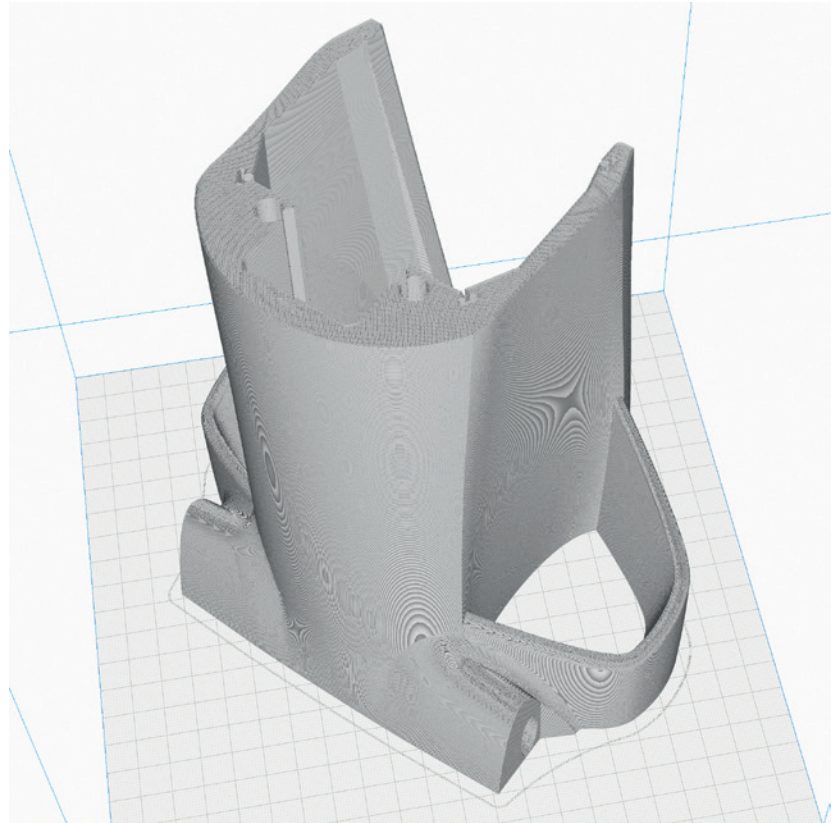

P5_FUS 4_ax.stl

MATERIAL LW PLA, Weight: ~ 95 g

TIME ~ 12 hours

ADDITIONAL SETTINGS

None required

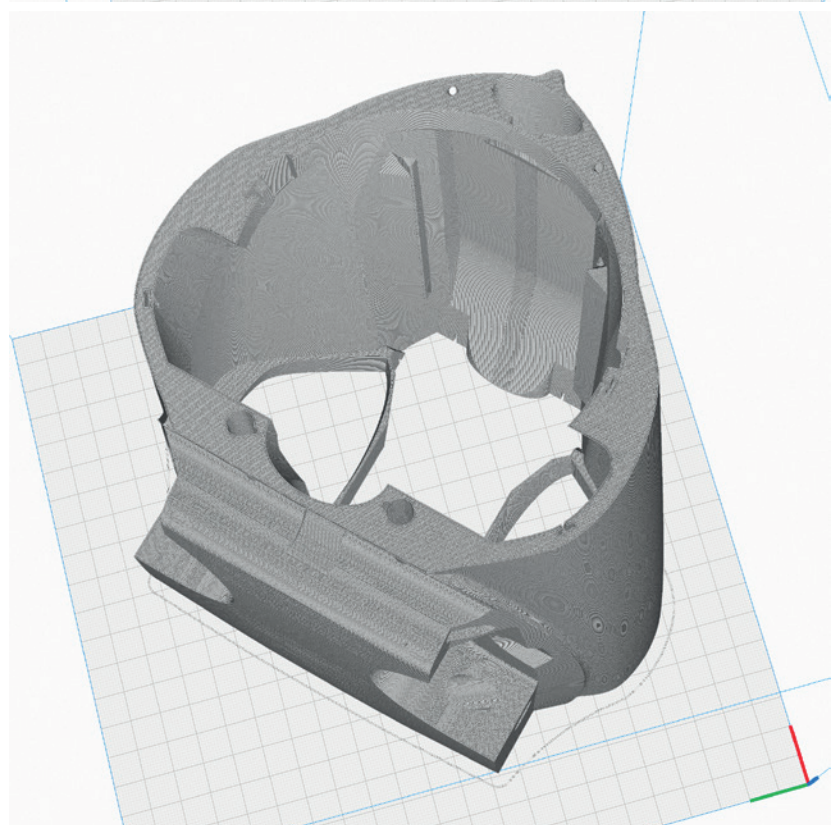

PROFILE P5_Gyroid LW-PLA (foaming)!



The information about the basic settings you can find on our website at PRINT.

Please note the additional settings for the individual parts!

It is essential to print these parts with foaming LW-PLA (pre-foamed is heavier)!

Basic settings for LW-PLA: Please follow the instructions in our **WINGTEST AND CALIBRATION TOOL** on our website for correct adjustment! Print only one STL at a time!

P5_FUS 5_ax.stl

MATERIAL LW PLA, Weight: ~ 63 g

TIME ~ 8 hours

ADDITIONAL SETTINGS

None required

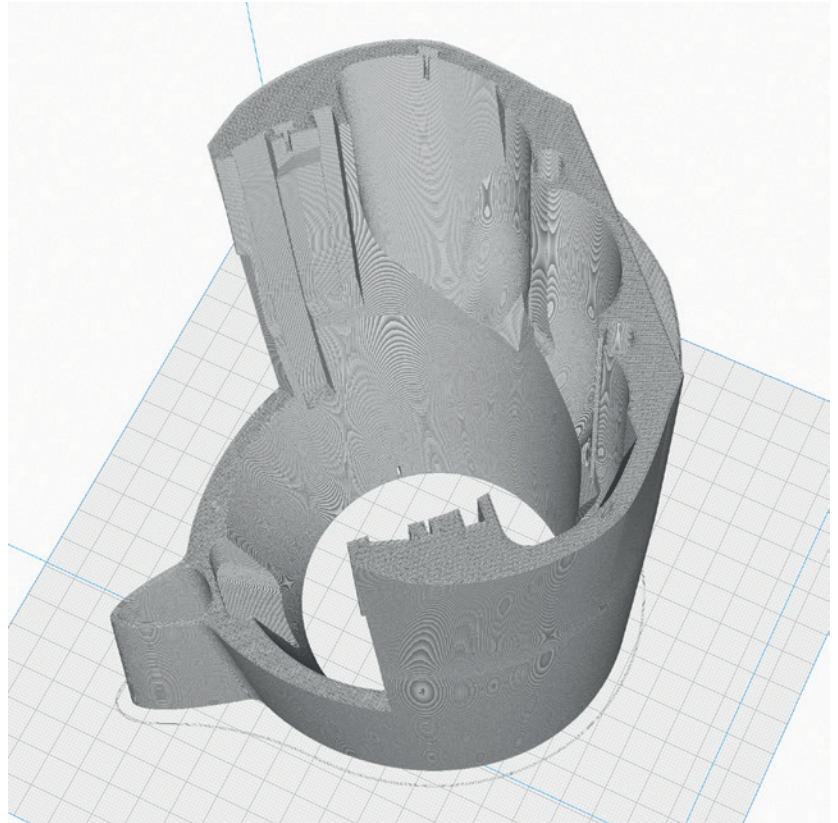

P5_FUS 6_ax.stl

MATERIAL LW PLA, Weight: ~ 70 g

TIME ~ 8 hours

ADDITIONAL SETTINGS

None required

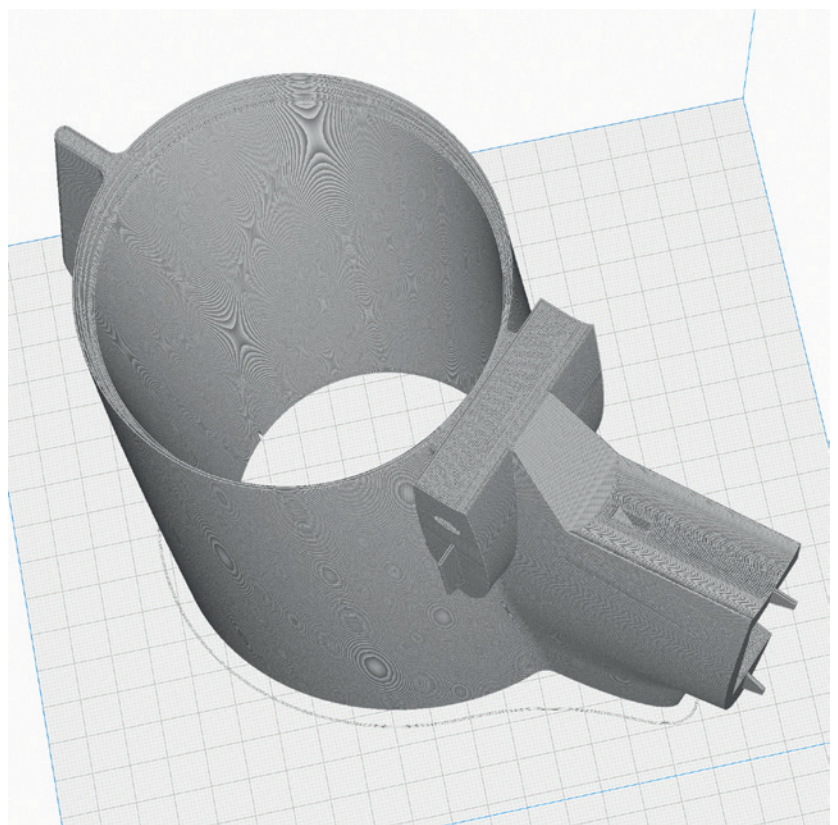

PROFILE P5_Gyroid LW-PLA (foaming)!



The information about the basic settings you can find on our website at PRINT.

Please note the additional settings for the individual parts!

It is essential to print these parts with foaming LW-PLA (pre-foamed is heavier)!

Basic settings for LW-PLA: Please follow the instructions in our **WINGTEST AND CALIBRATION TOOL** on our website for correct adjustment! Print only one STL at a time!

P5_HS L1_ax.stl and
P5_HS R1_ax.stl

MATERIAL LW PLA, Weight: ~ 14 g

TIME ~ 1 hour 15 minutes

ADDITIONAL SETTINGS

None required

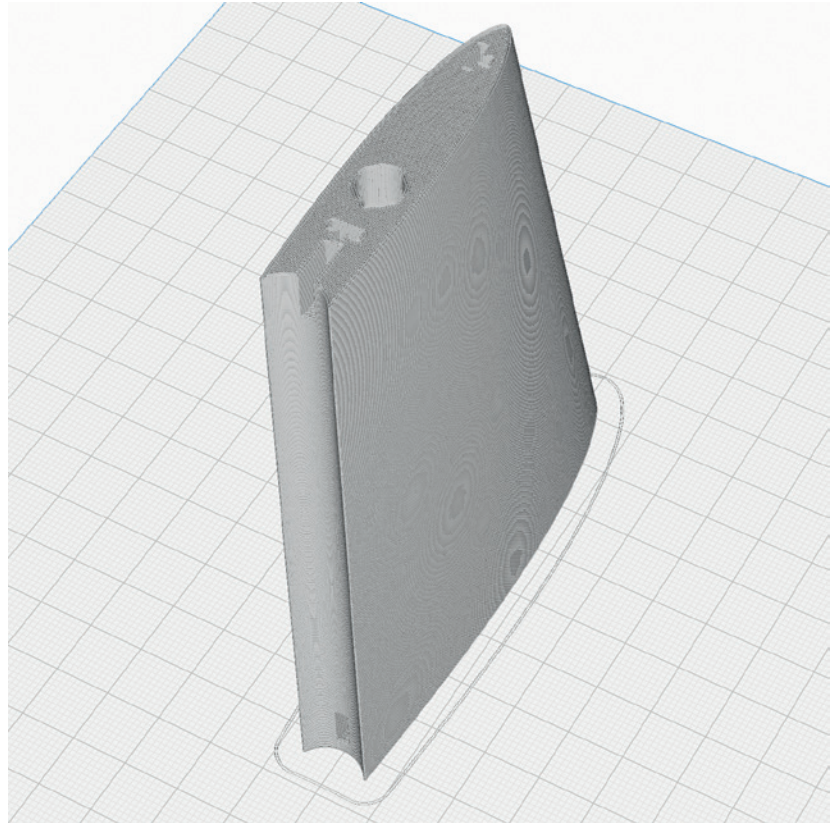

P5_HS L2_ax.stl and
P5_HS R2_ax.stl

MATERIAL LW PLA, Weight: ~ 5 g

TIME ~ 40 minutes

ADDITIONAL SETTINGS

None required

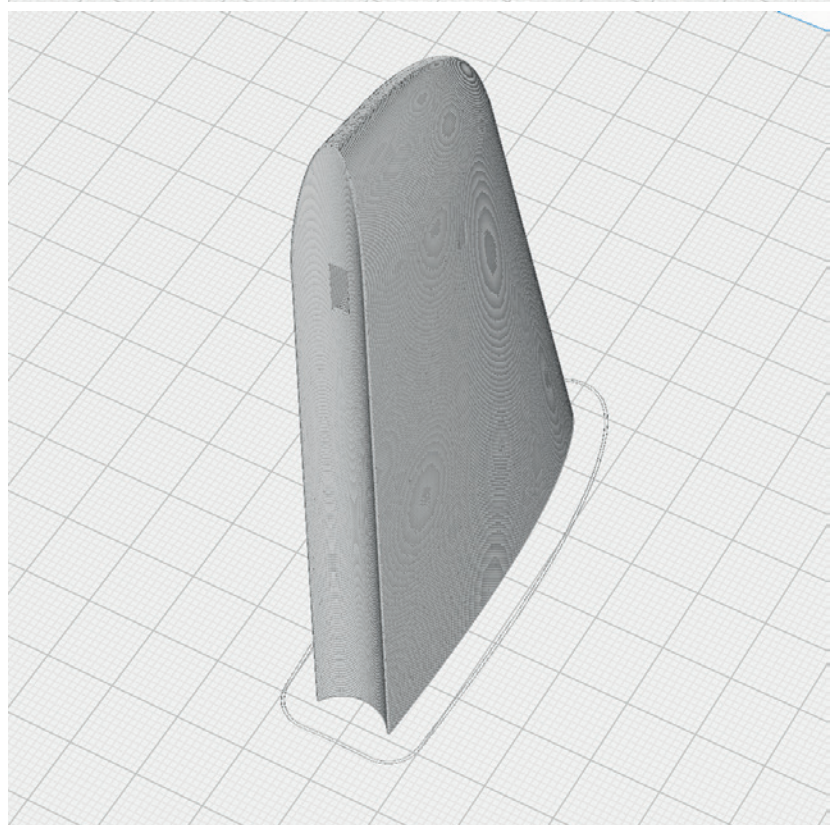

PROFILE P5_Gyroid LW-PLA (foaming)!



The information about the basic settings you can find on our website at PRINT.

Please note the additional settings for the individual parts!

It is essential to print these parts with foaming LW-PLA (pre-foamed is heavier)!

Basic settings for LW-PLA: Please follow the instructions in our **WINGTEST AND CALIBRATION TOOL** on our website for correct adjustment! Print only one STL at a time!

P5_Nose_ax.stl

MATERIAL LW PLA, Weight: ~ 5 g

TIME ~ 30 minutes

ADDITIONAL SETTINGS

None required

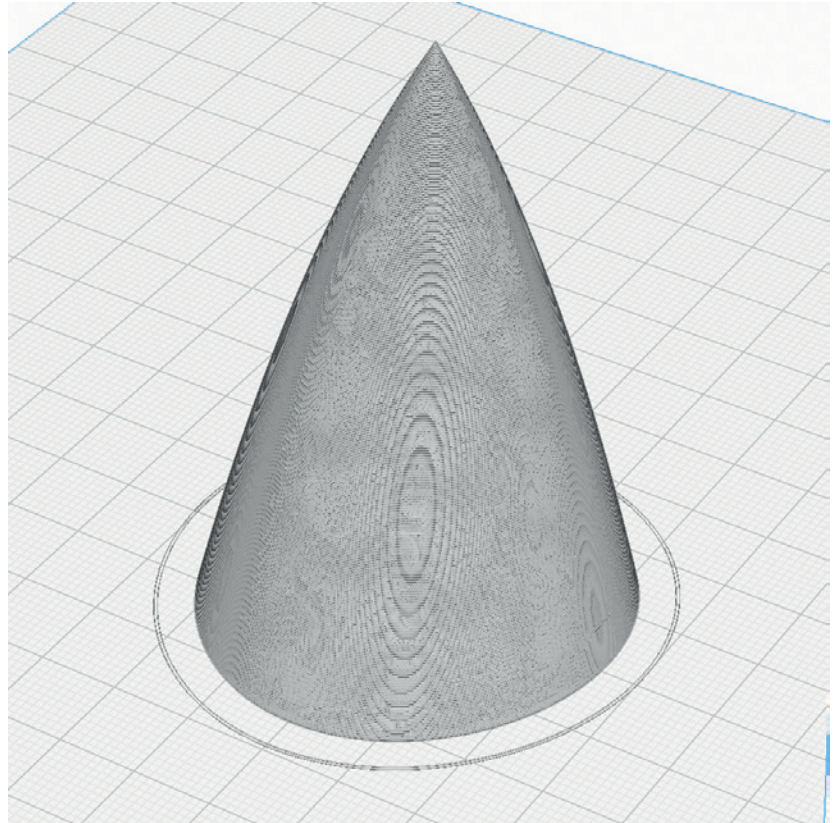

P5_Rudder 1_ax.stl

MATERIAL LW PLA, Weight: ~ 8 g

TIME ~ 1 hour

ADDITIONAL SETTINGS

None required

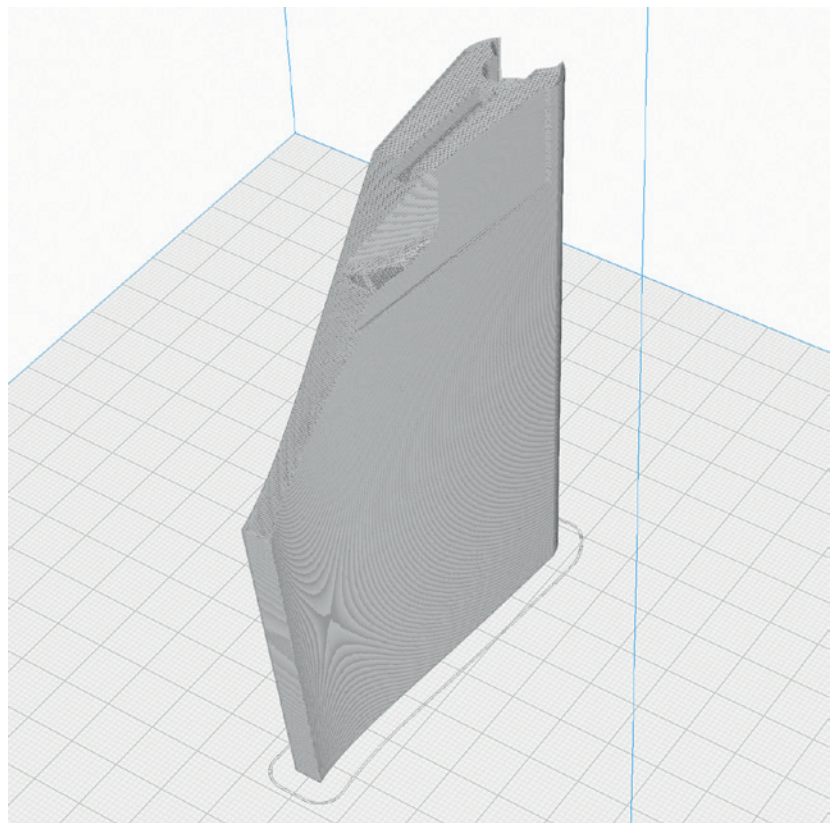

PROFILE P5_Gyroid LW-PLA (foaming)!



The information about the basic settings you can find on our website at PRINT.

Please note the additional settings for the individual parts!

It is essential to print these parts with foaming LW-PLA (pre-foamed is heavier)!

Basic settings for LW-PLA: Please follow the instructions in our **WINGTEST AND CALIBRATION TOOL** on our website for correct adjustment! Print only one STL at a time!

P5_Rudder 2_ax.stl

MATERIAL LW PLA, Weight: ~ 9 g

TIME ~ 1 hour

ADDITIONAL SETTINGS

None required

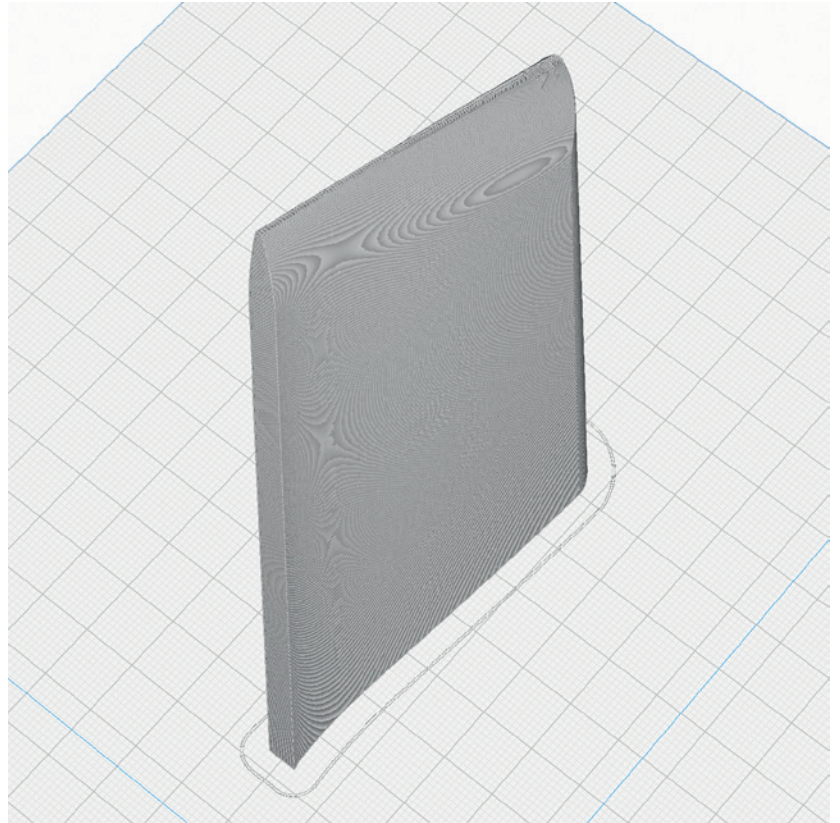

P5_Servo Cover Tail_ax.stl

MATERIAL LW PLA, Weight: ~ 3 g

TIME ~ 15 minutes

ADDITIONAL SETTINGS

- use Brim

If the holes don't fit your servos, this version is available for manual adjustment.

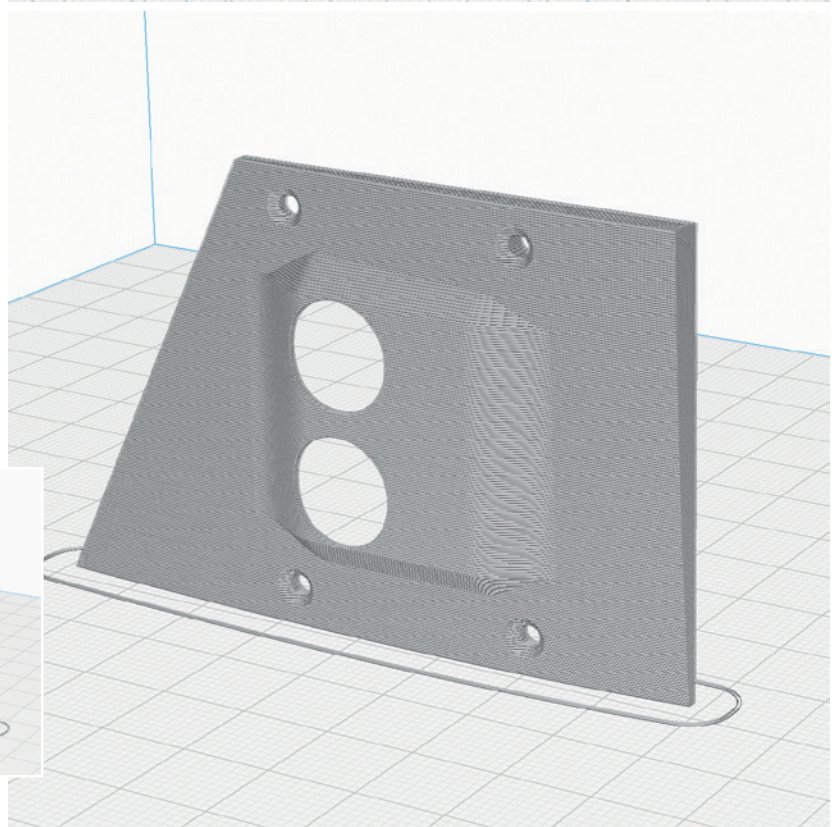
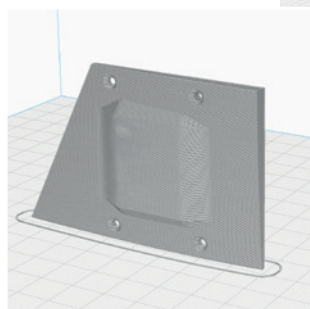

PROFILE P5_Gyroid LW-PLA (foaming)!



The information about the basic settings you can find on our website at PRINT.

Please note the additional settings for the individual parts!

It is essential to print these parts with foaming LW-PLA (pre-foamed is heavier)!

Basic settings for LW-PLA: Please follow the instructions in our **WINGTEST AND CALIBRATION TOOL** on our website for correct adjustment! Print only one STL at a time!

P5_VS_ax.stl

MATERIAL LW PLA, Weight: ~ 18 g

TIME ~ 2 hours 20 minutes

ADDITIONAL SETTINGS

None required

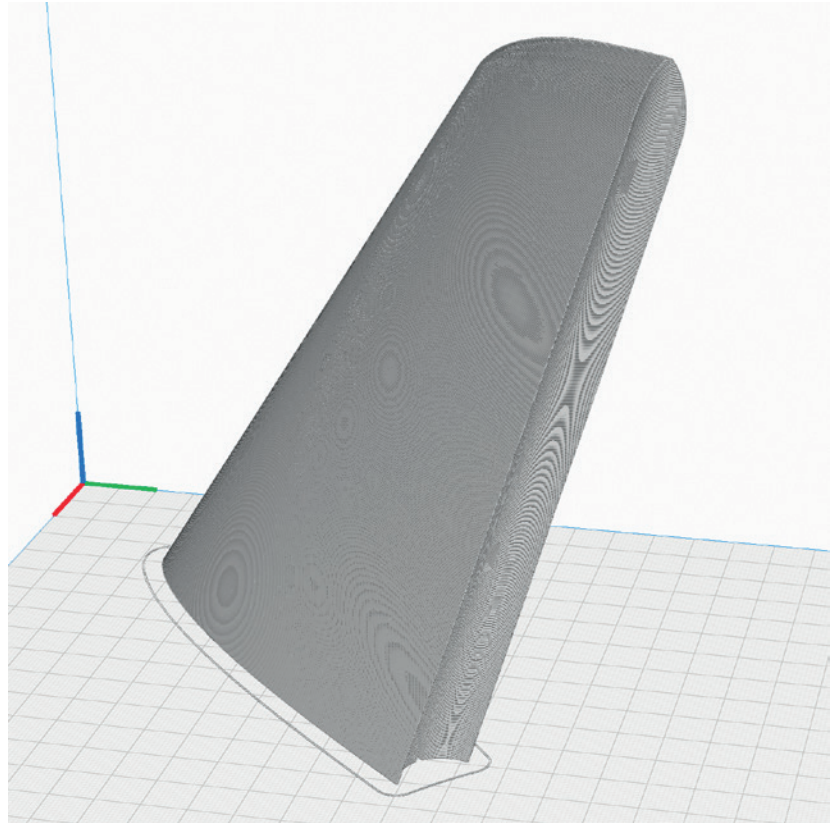

P5_Wing L1_ax.stl or P5_Wing R1_ax.stl

MATERIAL LW PLA, Weight: ~ 40 g

TIME ~ 5 hours

ADDITIONAL SETTINGS

None required

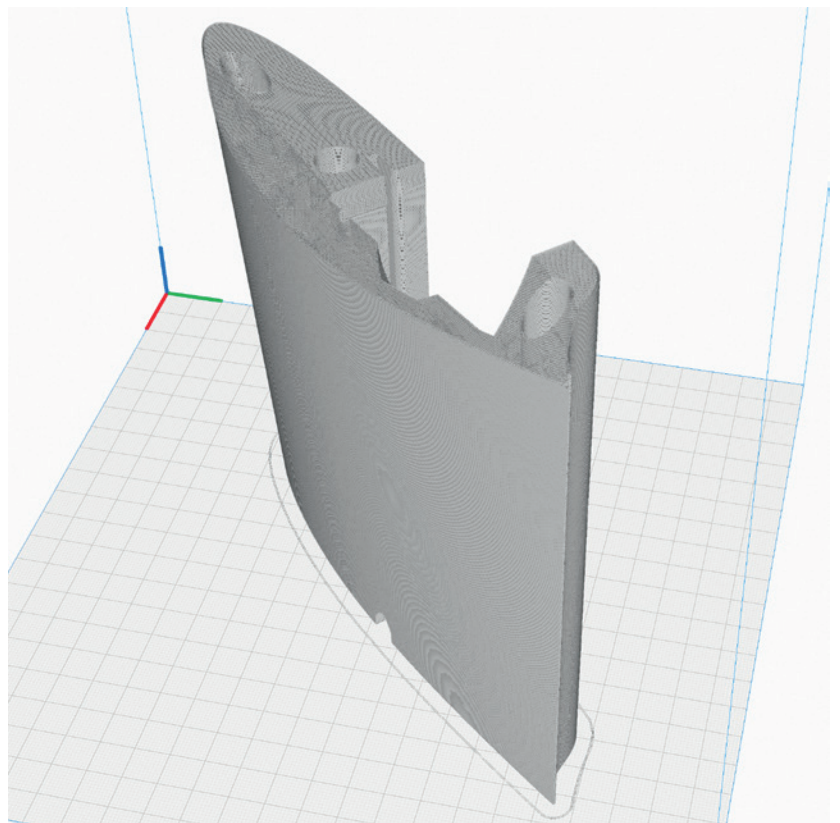

PROFILE P5_Gyroid LW-PLA (foaming)!



The information about the basic settings you can find on our website at PRINT.

Please note the additional settings for the individual parts!

It is essential to print these parts with foaming LW-PLA (pre-foamed is heavier)!

Basic settings for LW-PLA: Please follow the instructions in our **WINGTEST AND CALIBRATION TOOL** on our website for correct adjustment! Print only one STL at a time!

P5_Wing L2_ax.stl or
P5_Wing R2_ax.stl

MATERIAL LW PLA, Weight: ~ 38 g

TIME ~ 5 hours

ADDITIONAL SETTINGS

None required

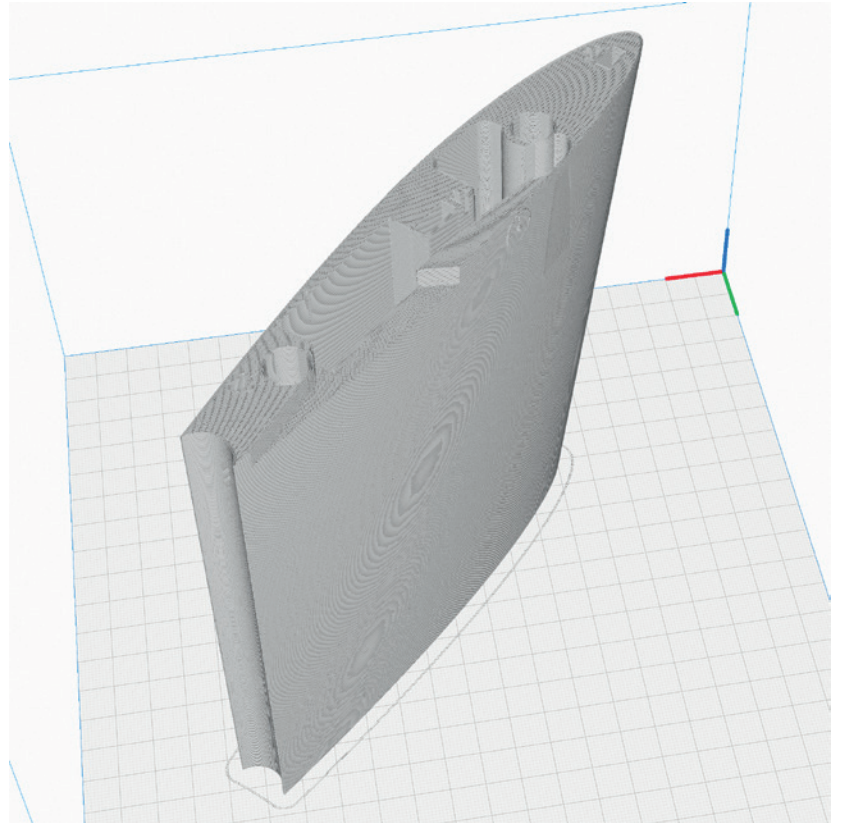

P5_Wing L3_ax.stl or
P5_Wing R3_ax.stl

MATERIAL LW PLA, Weight: ~ 26 g

TIME ~ 3 hours 20 minutes

ADDITIONAL SETTINGS

None required

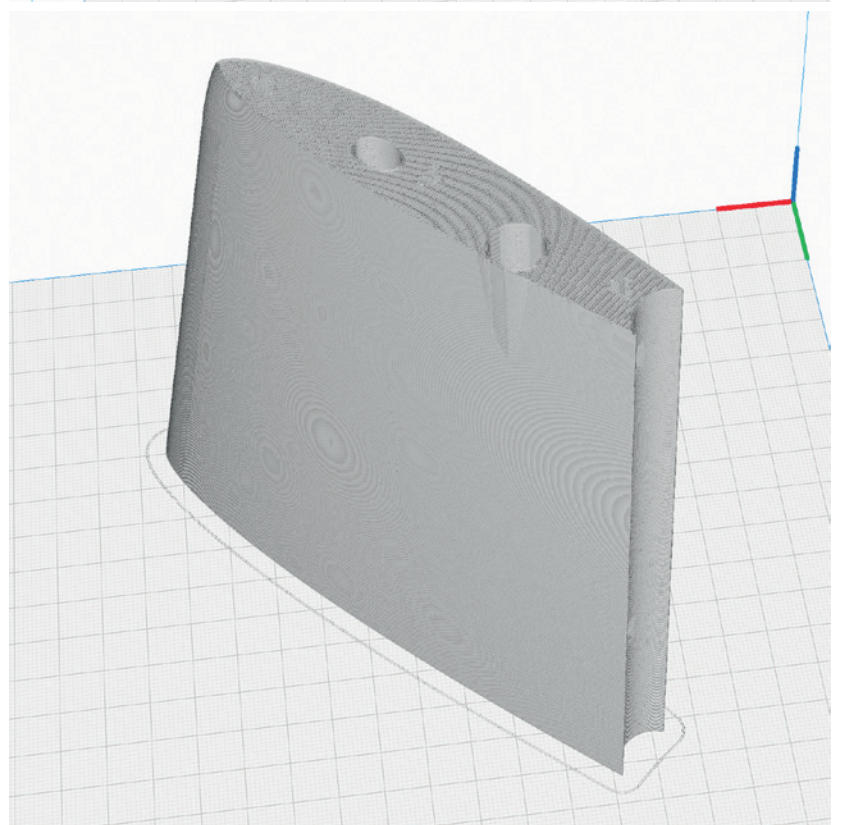

PROFILE P5_Gyroid LW-PLA (foaming)!



The information about the basic settings you can find on our website at PRINT.

Please note the additional settings for the individual parts!

It is essential to print these parts with foaming LW-PLA (pre-foamed is heavier)!

Basic settings for LW-PLA: Please follow the instructions in our **WINGTEST AND CALIBRATION TOOL** on our website for correct adjustment! Print only one STL at a time!

P5_Wing L4_ax.stl [or](#)
P5_Wing R4_ax.stl

MATERIAL LW PLA, Weight: ~ 9 g

TIME ~ 50 minutes

ADDITIONAL SETTINGS

None required

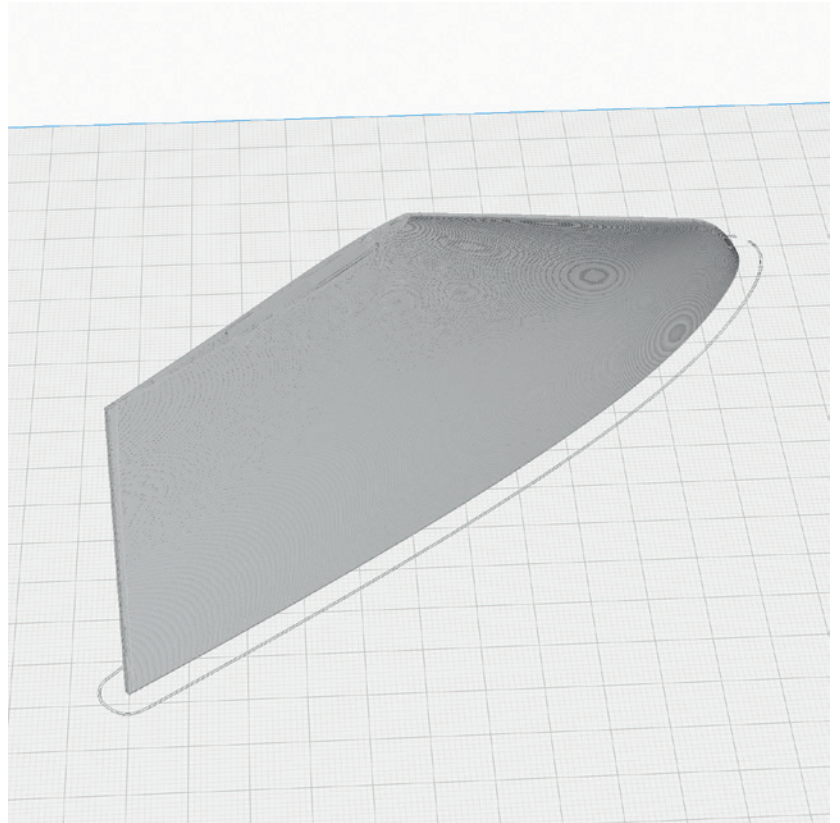

Basic Information:

Gluing the parts printed with PROFILE P5

- STEP 1** As a first step, it is important to **roughen and smooth the adhesive surfaces** with sandpaper.
- STEP 2** Insert the **interconnects into the slots** provided on one side.
- STEP 3** Apply a **lot of glue** to the side with the interconnects. It is important that there is glue everywhere, especially on the outside and inside of the wall surfaces, in order to achieve a perfect connection. The interconnects only serve to align the parts to each other. It is better **not** to apply glue here, otherwise it can happen that the glue suddenly hardens while the parts are being put together and stops the process.

Use medium viscosity CA glue, thinner glue would run down the parts too easily.

After assembly, **align the two parts exactly** and wipe off the excess CA glue from the surface with a cloth. Now spray with activator spray along the gluing surface and carefully press the parts together.

- STEP 4** Clean the glued areas slightly with a **sharp-bladed** cutter.



PROFILES 5 parts are easy to repair

- STEP 1** Using the knife, carefully remove the damaged part about 3 mm from the glue joint between two parts.
- STEP 2** Cut wall and infill and clean the surface with sandpaper. **The top surface of the damaged part remains!**
- STEP 3** The remaining top surface is about 1 mm thick. To compensate for this, you can move the new part to be printed down the Z axis in Cura by 1 mm.

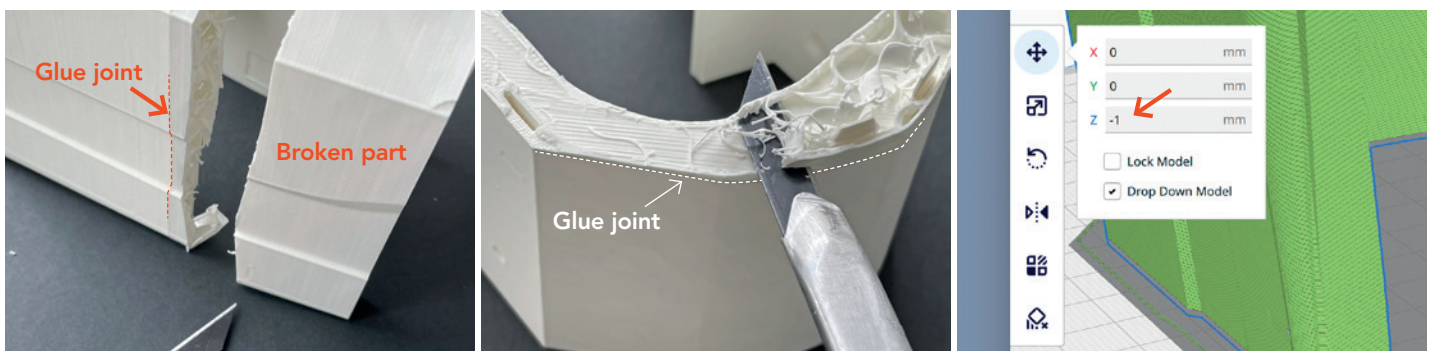

Fuselage assembly



TIP Always put all parts together **BEFORE** gluing and check that everything runs smoothly and fits exactly.

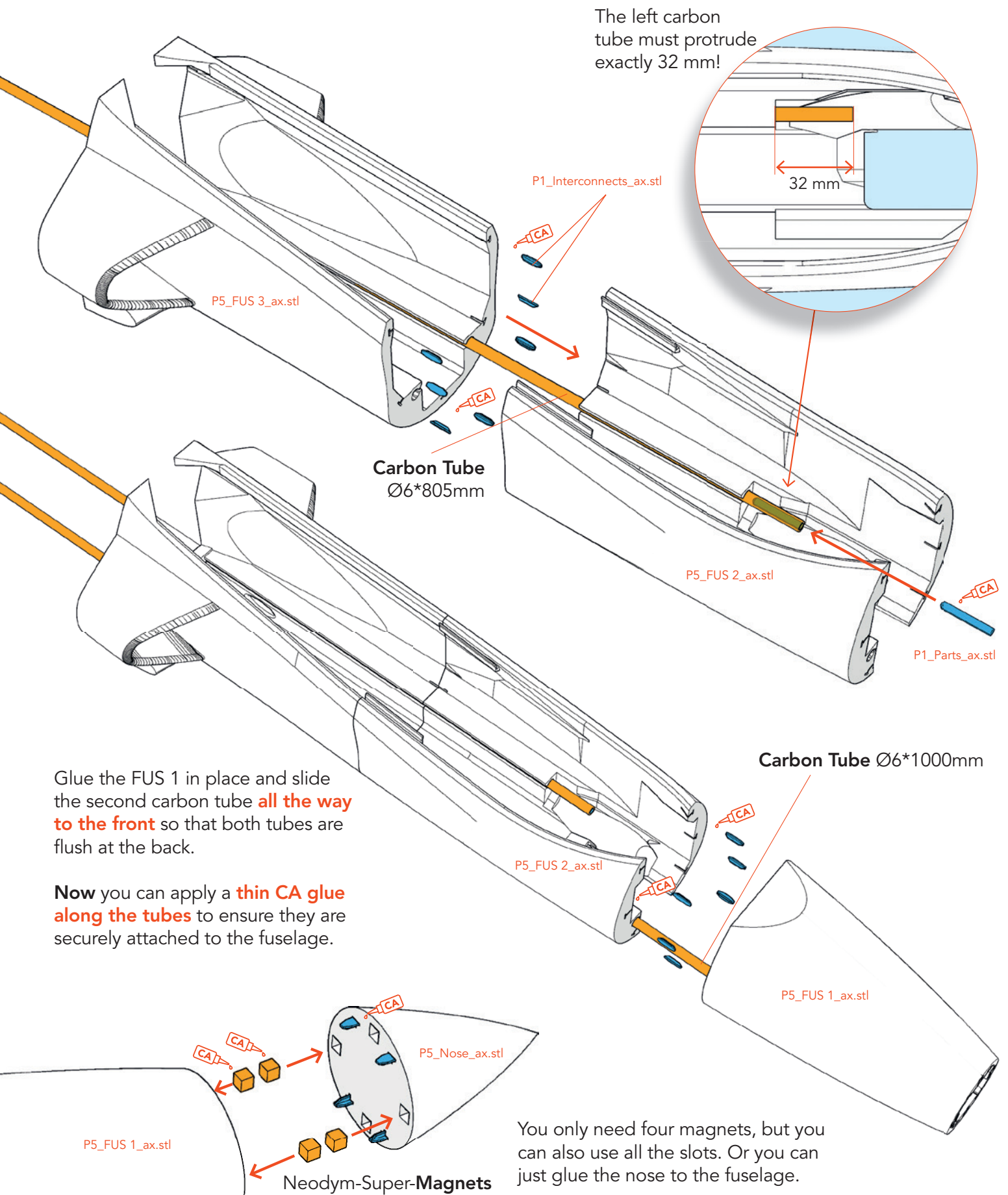

Glue the FUS 1 in place and slide the second carbon tube **all the way to the front** so that both tubes are flush at the back.

Now you can apply a **thin CA glue** along the tubes to ensure they are securely attached to the fuselage.

You only need four magnets, but you can also use all the slots. Or you can just glue the nose to the fuselage.

Fuselage assembly



Apply a **thin CA glue** along the **tubes** to ensure they are securely attached to the fuselage.

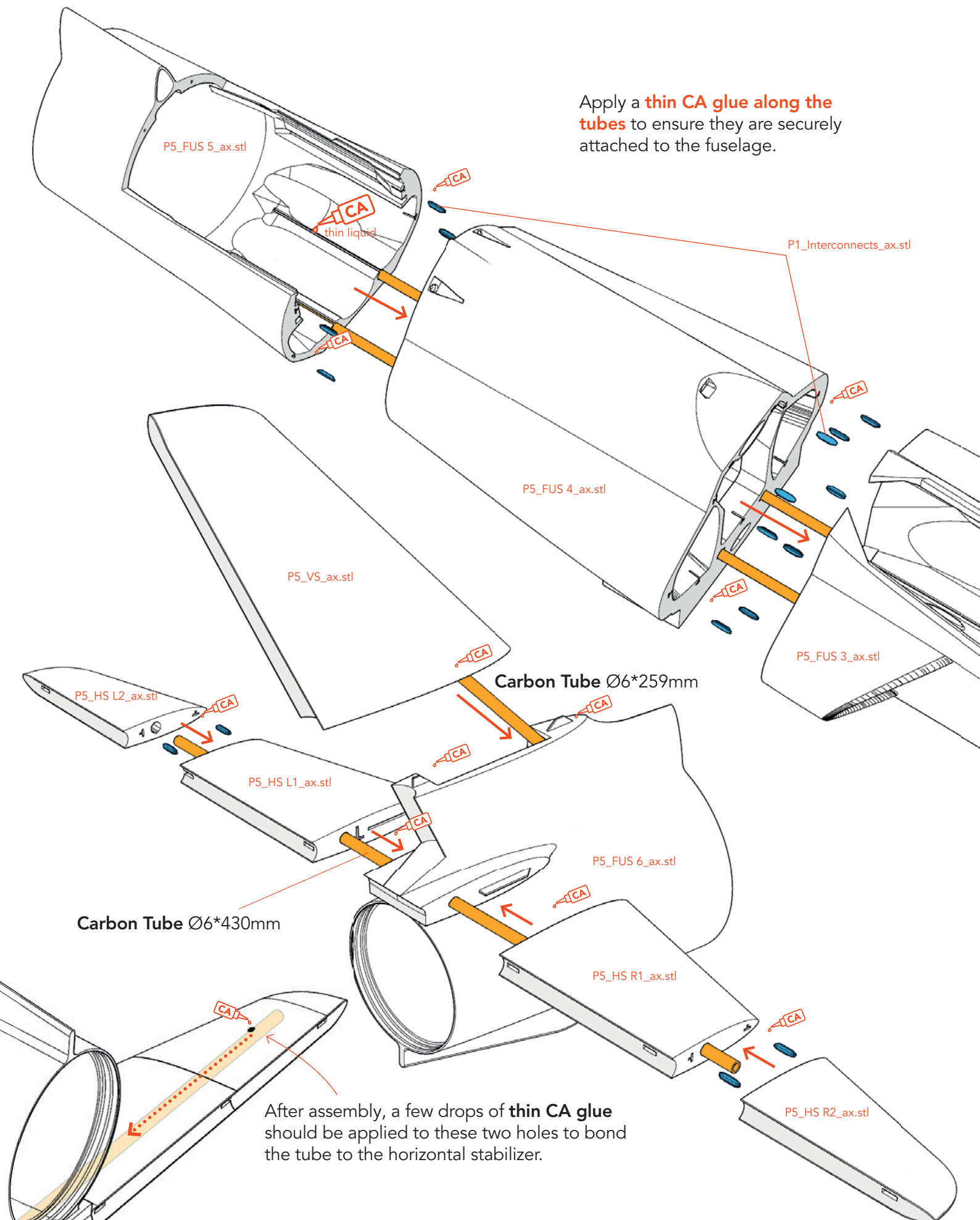

Rudder assembly



Assemble the rudder as shown in the picture, and finally insert the steel wire to serve as a hinge. **Make sure the rudder moves smoothly!**

Steel wire $\varnothing 1 \times 236 \text{mm}$

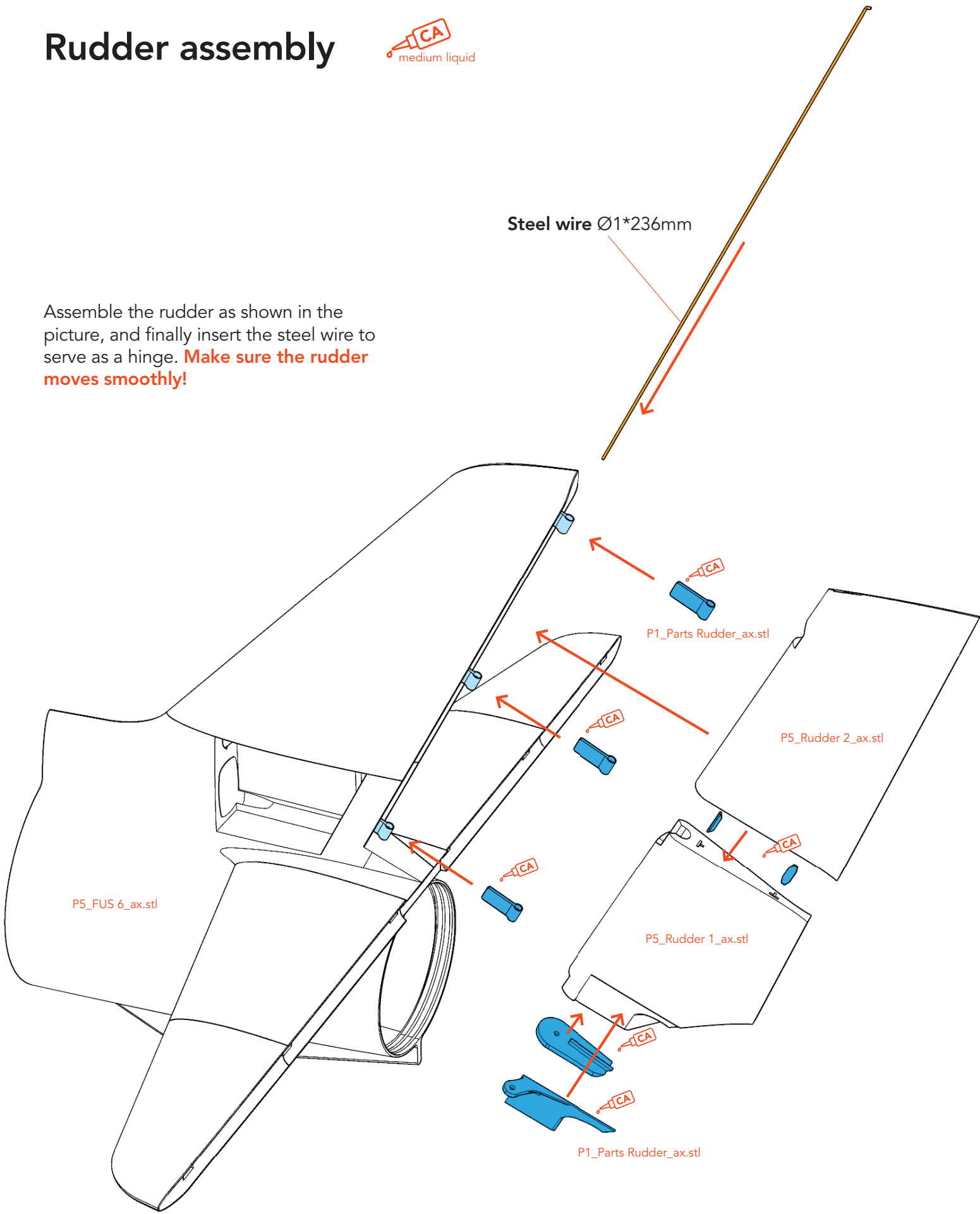

Elevator assembly

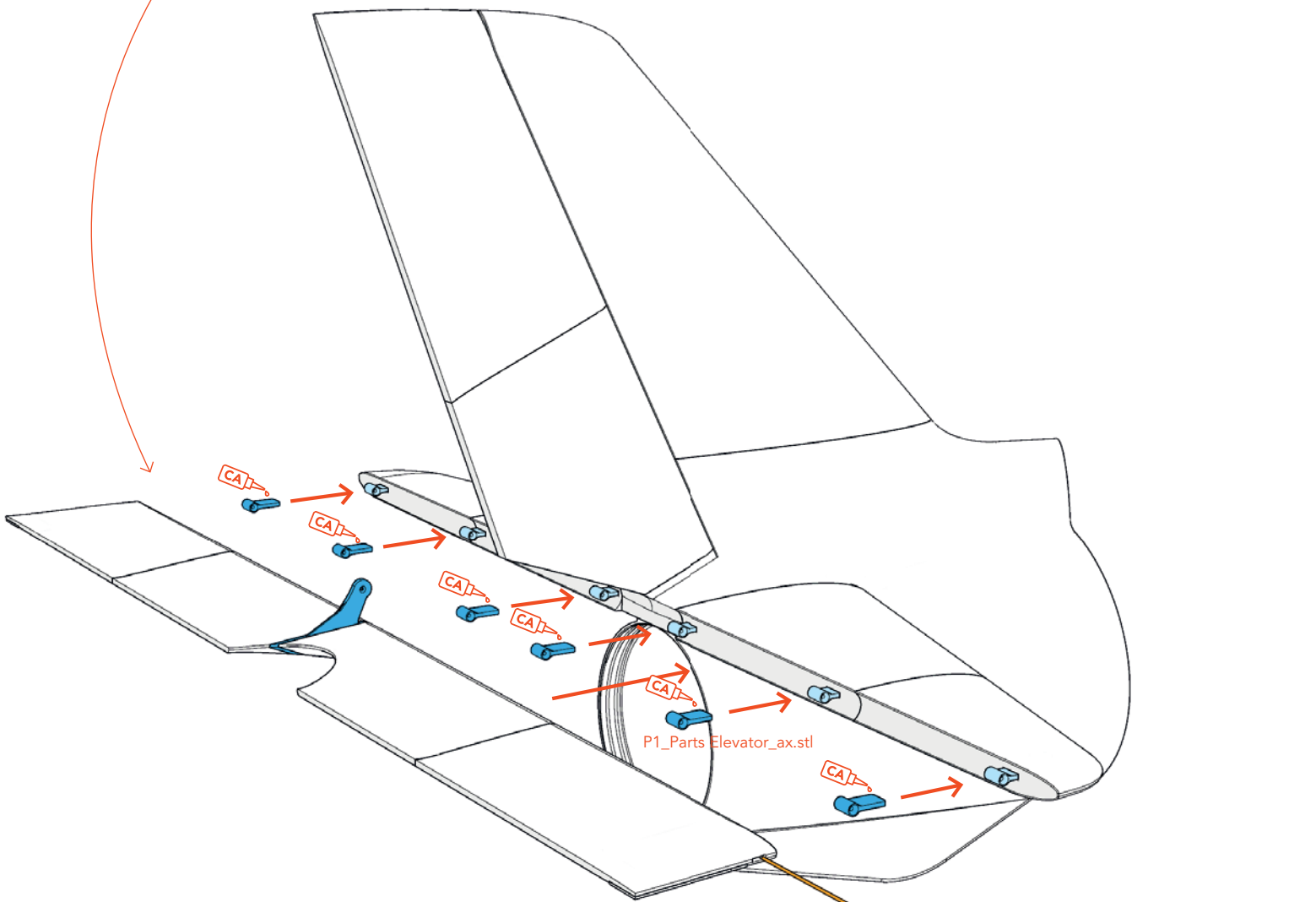
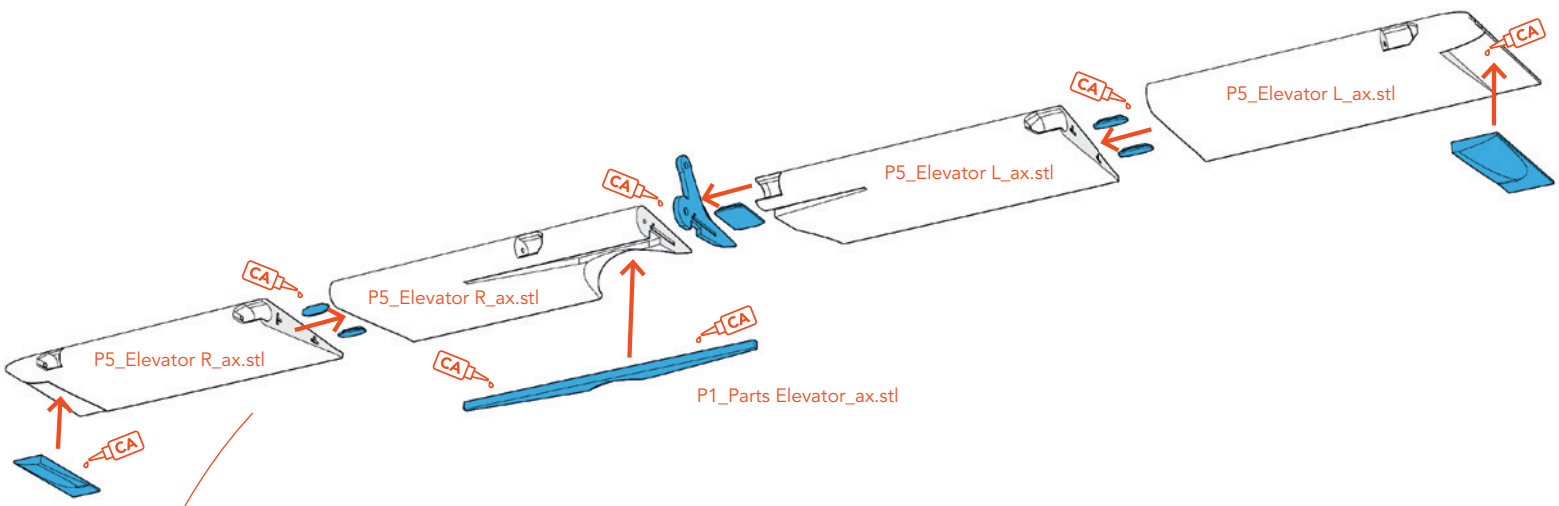

Assemble the elevator as shown in the picture, and finally insert the steel wire to serve as a hinge. **Make sure the elevator moves smoothly!**

Steel wire $\text{Ø}1 \times 487\text{mm}$

Fuselage assembly

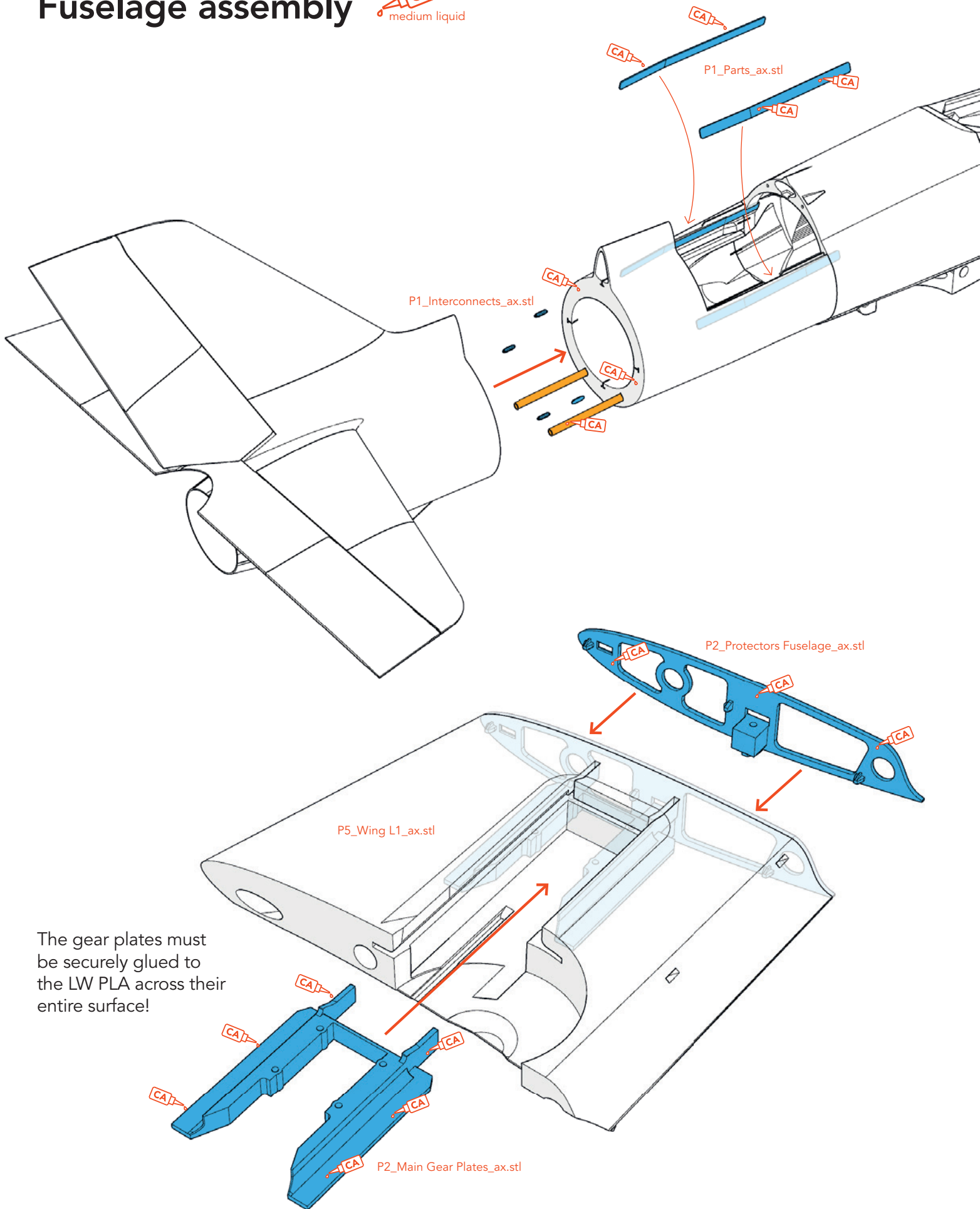

The gear plates must be securely glued to the LW PLA across their entire surface!

Fuselage assembly

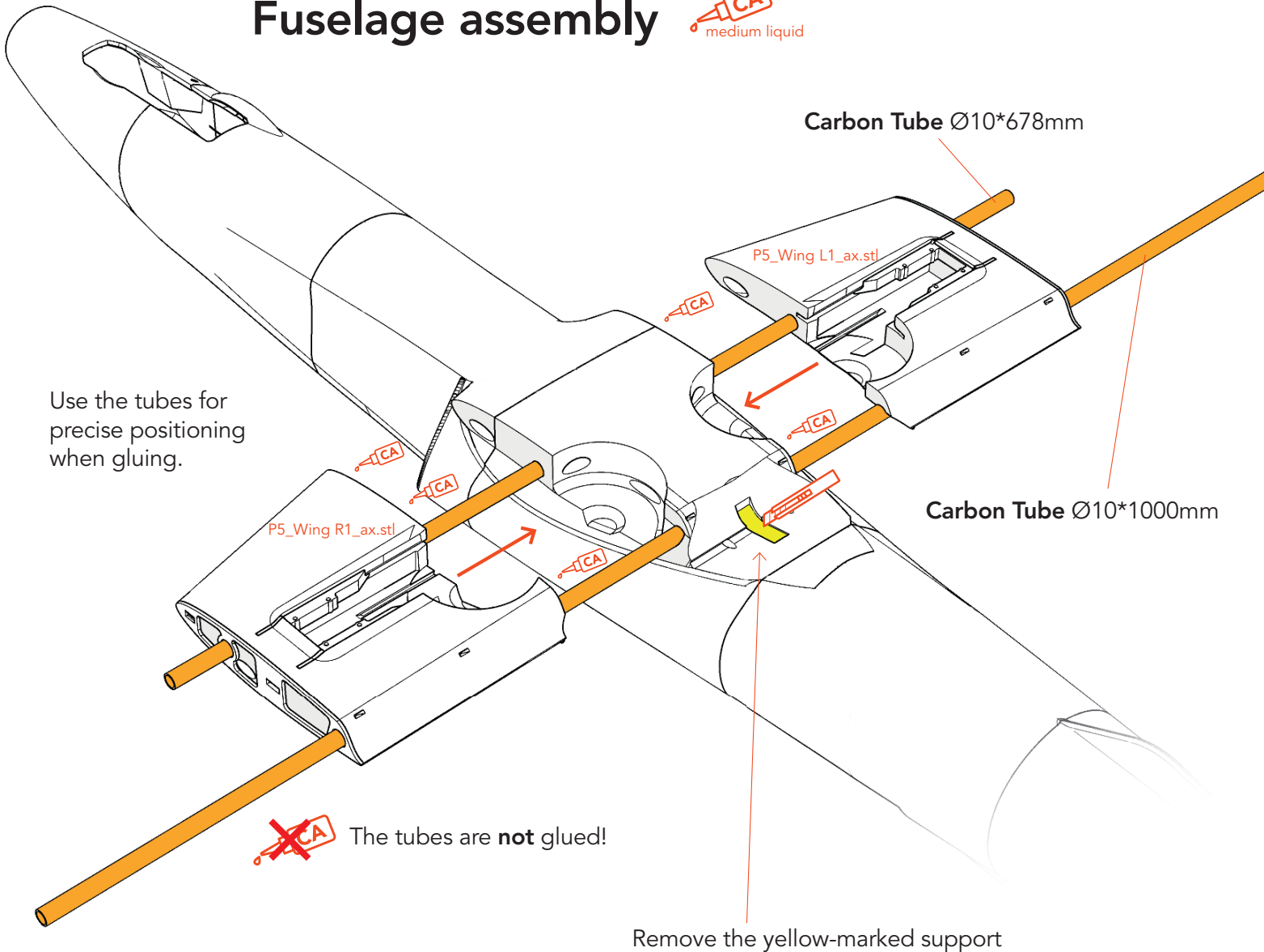

Use the tubes for precise positioning when gluing.

~~CA~~ The tubes are **not** glued!

Remove the yellow-marked support

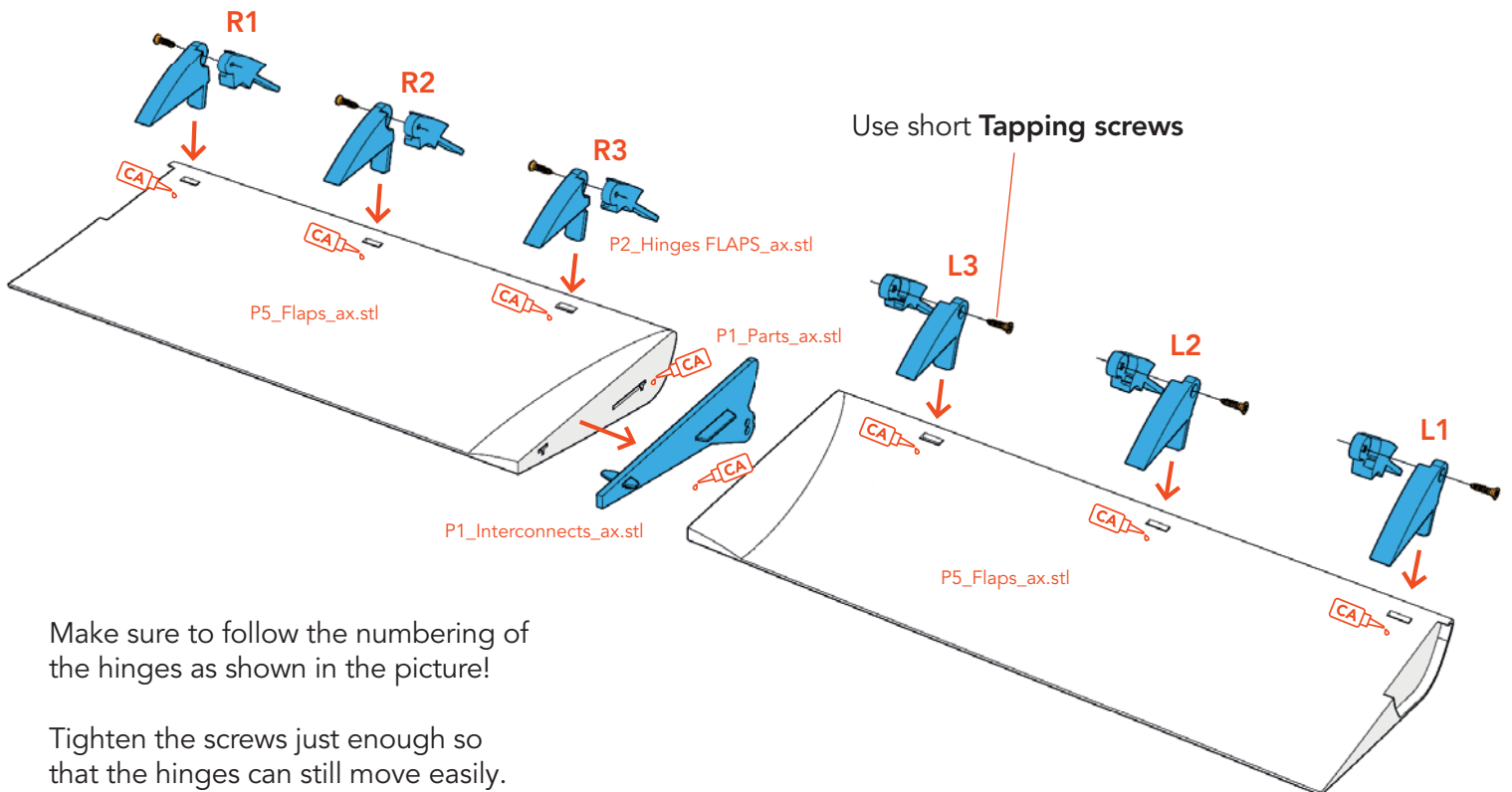

Make sure to follow the numbering of the hinges as shown in the picture!

Tighten the screws just enough so that the hinges can still move easily.

Landing Flaps



First, insert the flap with the hinges into the slots and check that everything moves properly. Then apply thin CA glue to the hinges.

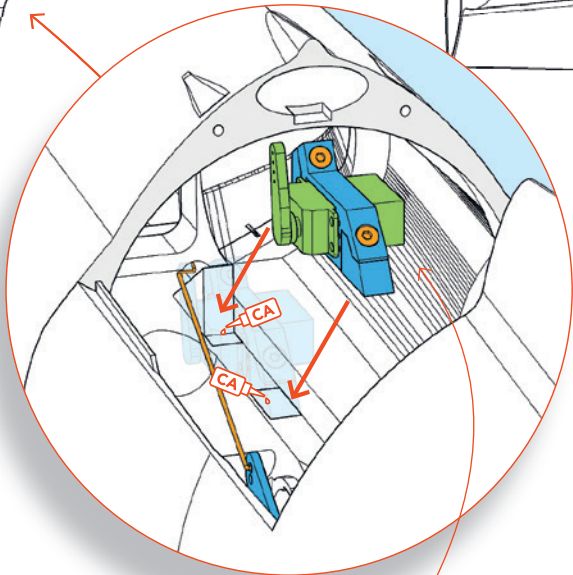
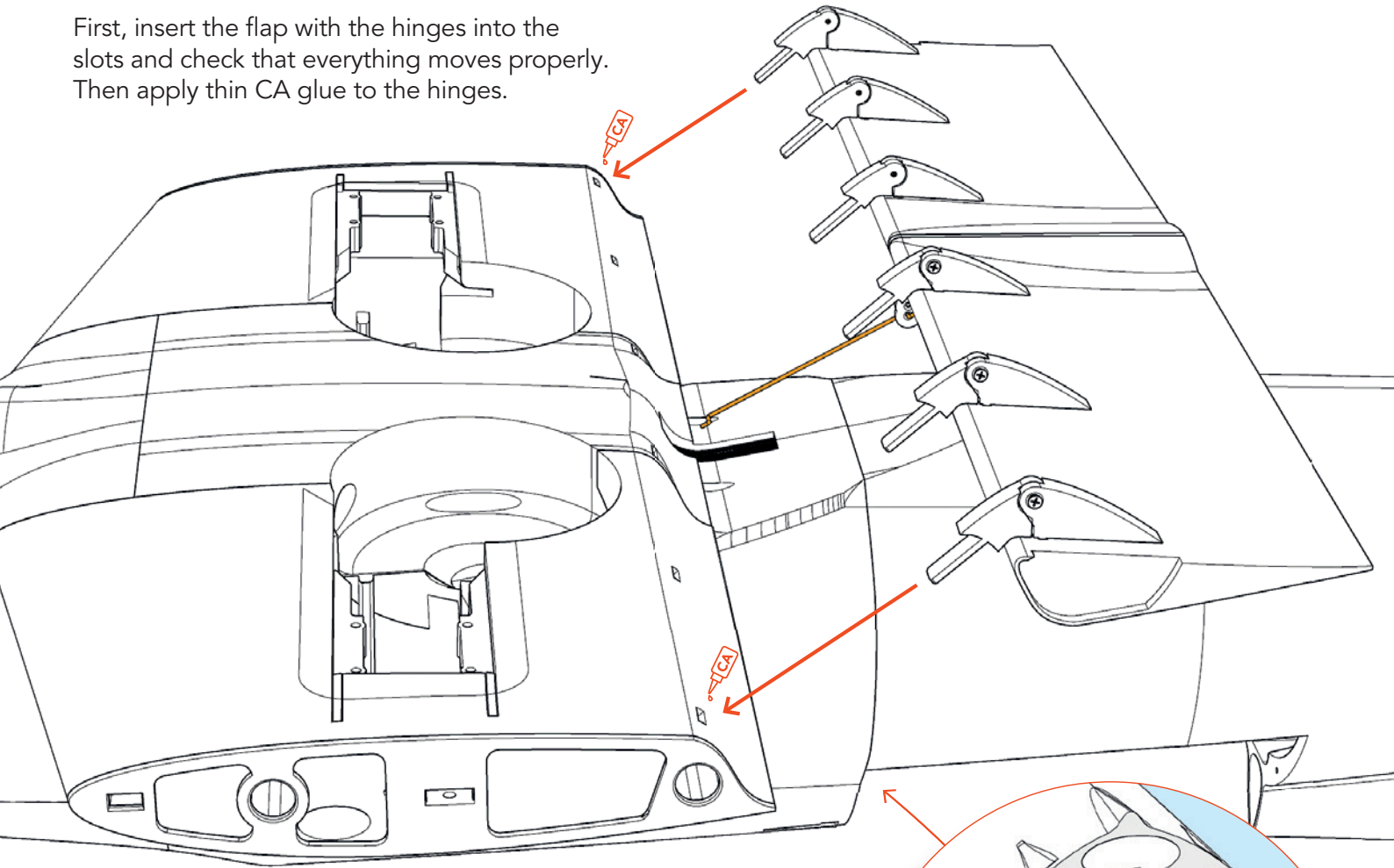

Steel wire $\text{Ø}1 \times 65 \text{ mm}$

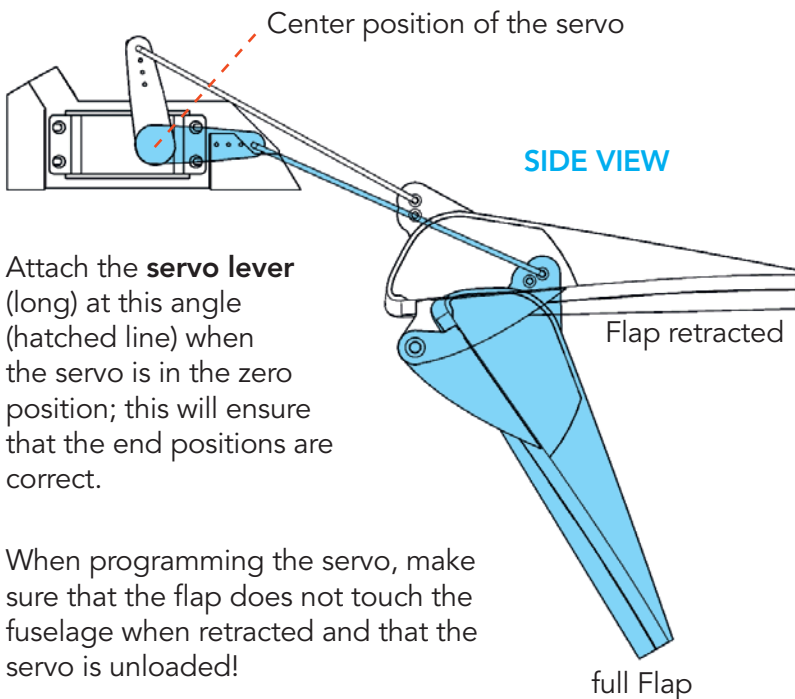

SIDE VIEW

Attach the **servo lever** (long) at this angle (hatched line) when the servo is in the zero position; this will ensure that the end positions are correct.

When programming the servo, make sure that the flap does not touch the fuselage when retracted and that the servo is unloaded!

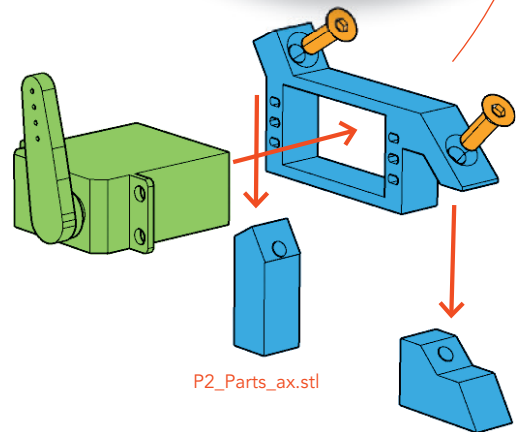

P2_Parts_ax.stl

Wing assembly

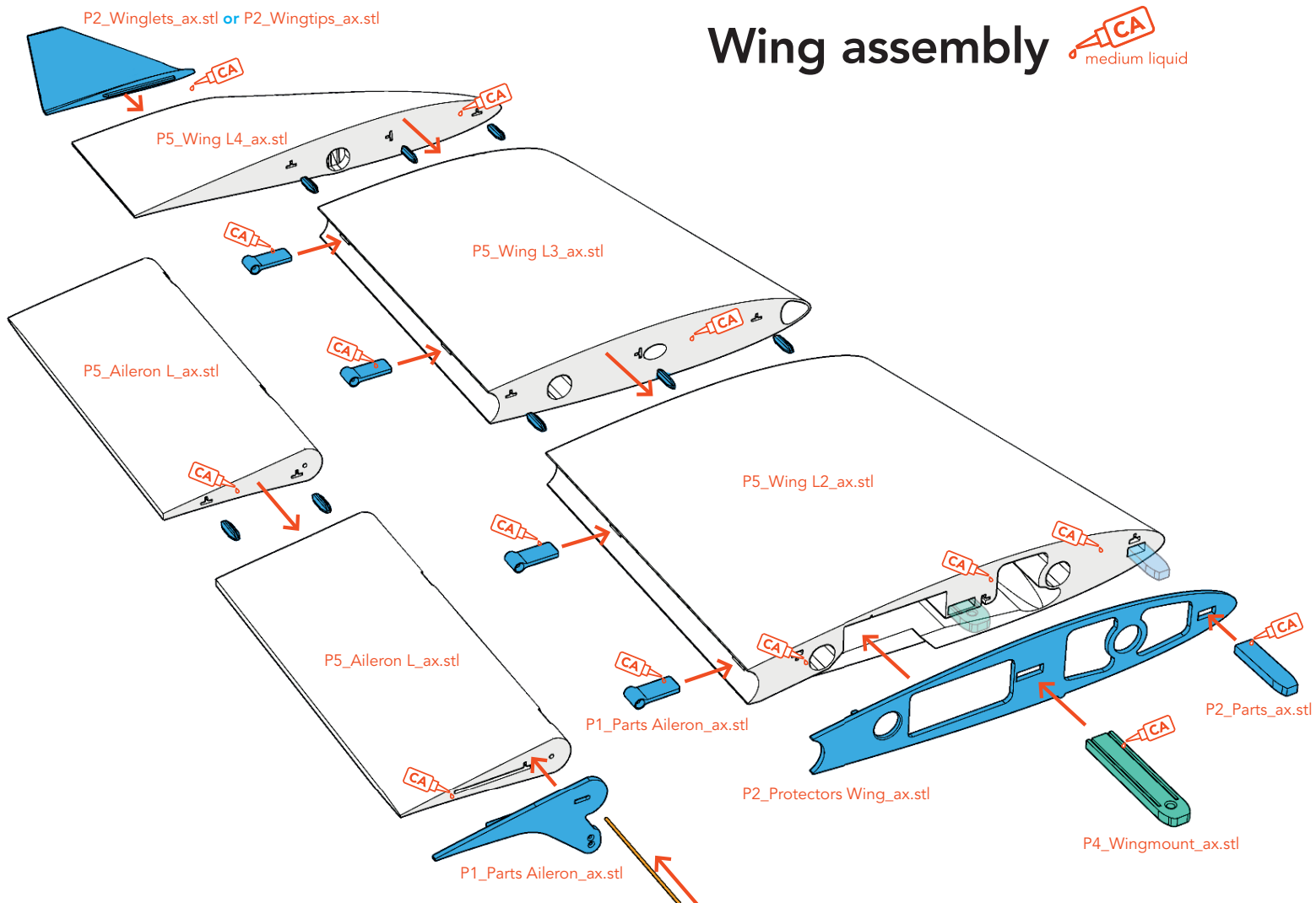

Aileron Servos



Screw the servo onto the brackets and position everything without using any glue. The servo lever should point slightly forward in the neutral position (differential). Only once everything fits perfectly should you apply a small amount of thin CA glue to the brackets.

Steel wire $\varnothing 1 \times 290\text{mm}$

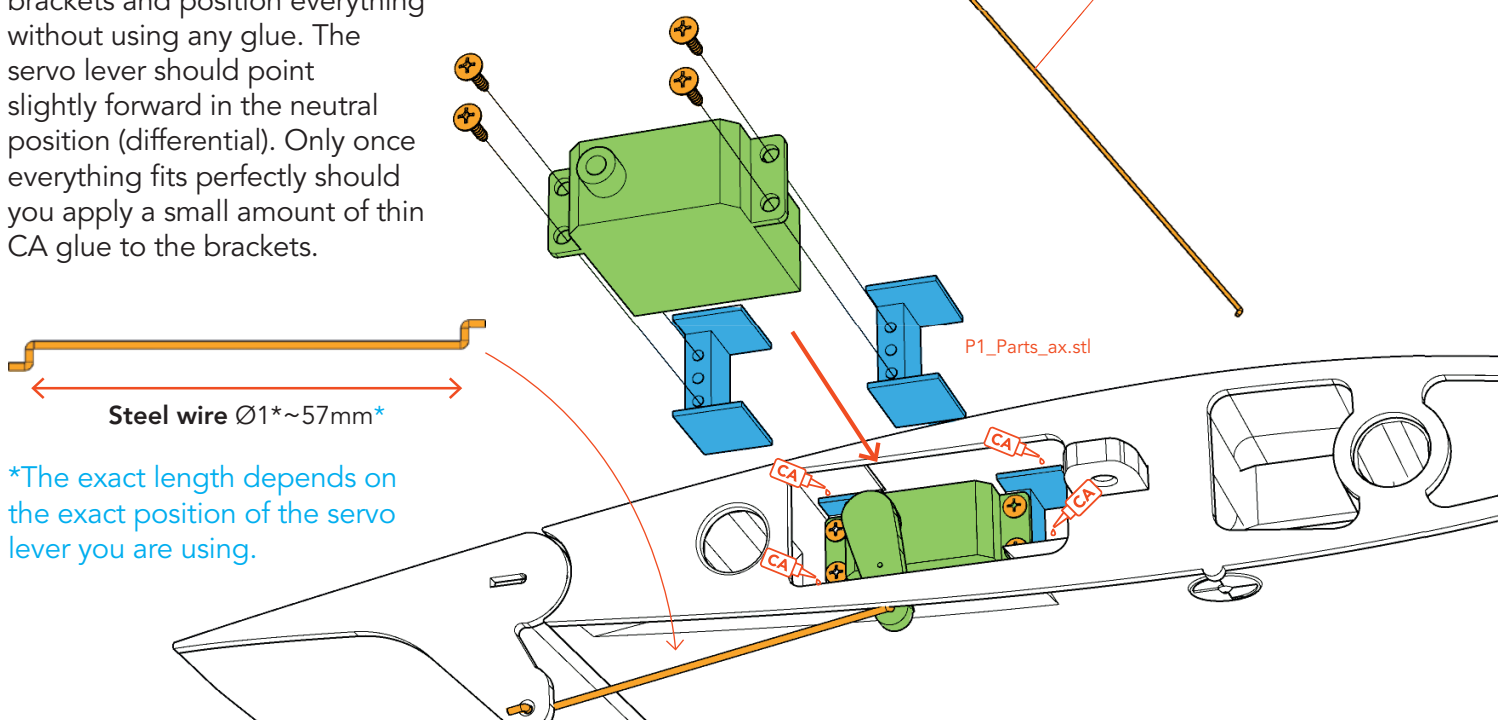

*The exact length depends on the exact position of the servo lever you are using.

Wing fastening

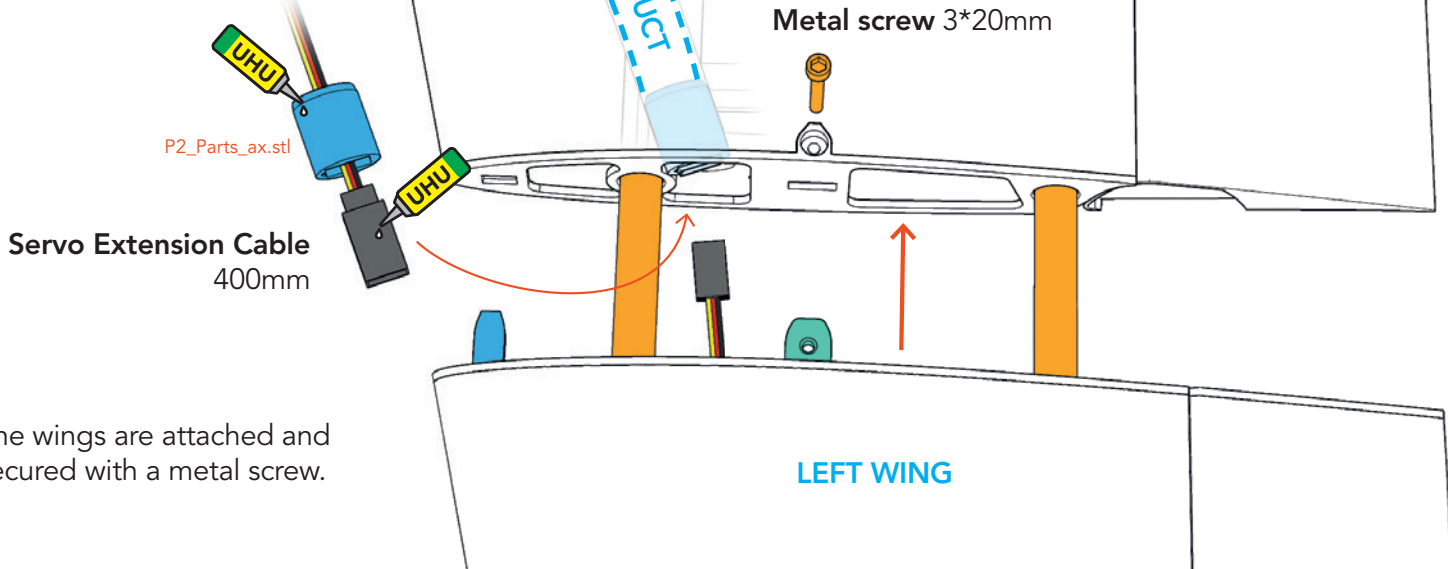

The wings are attached and secured with a metal screw.

Tail Servos

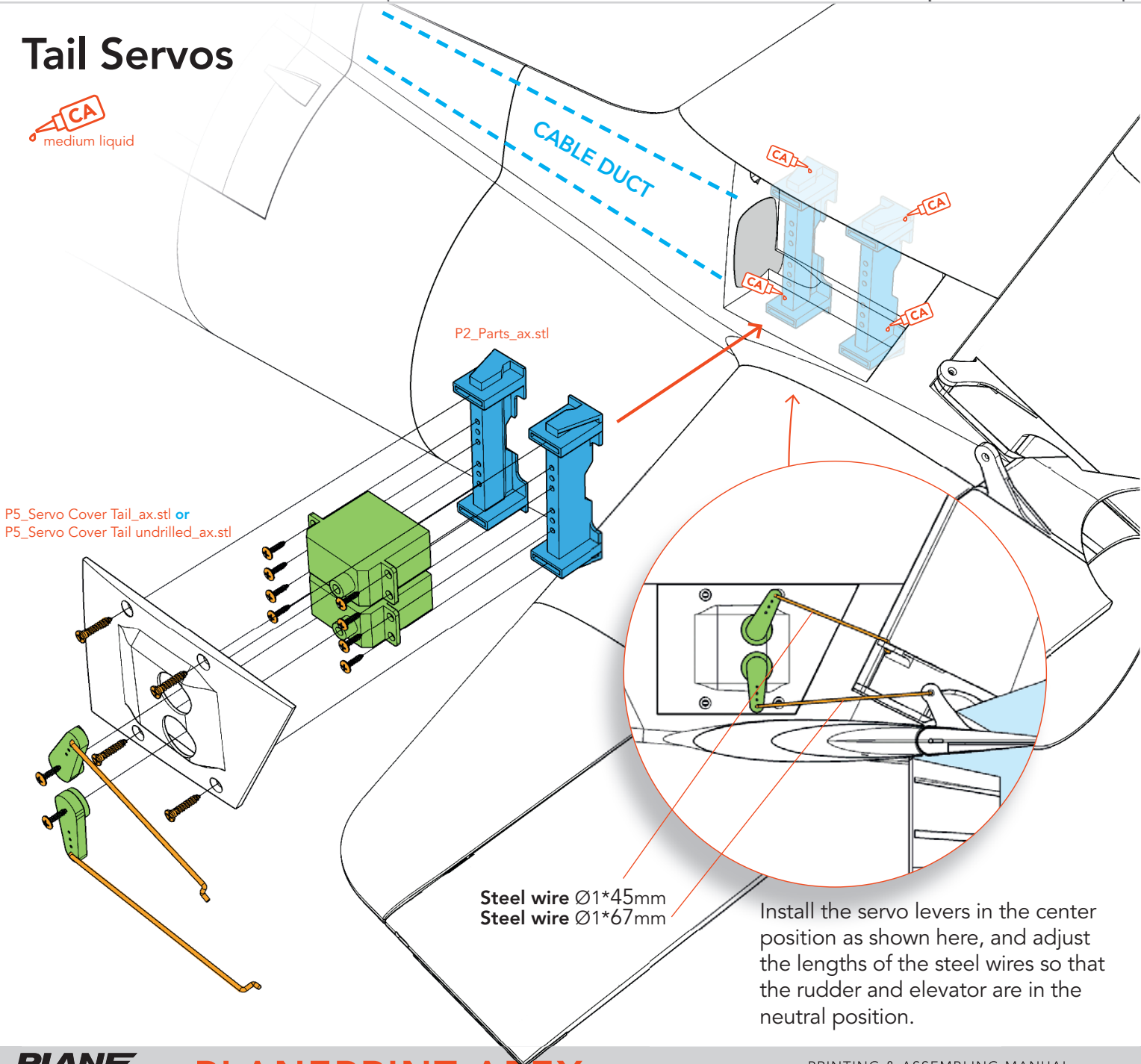

EDF Mount

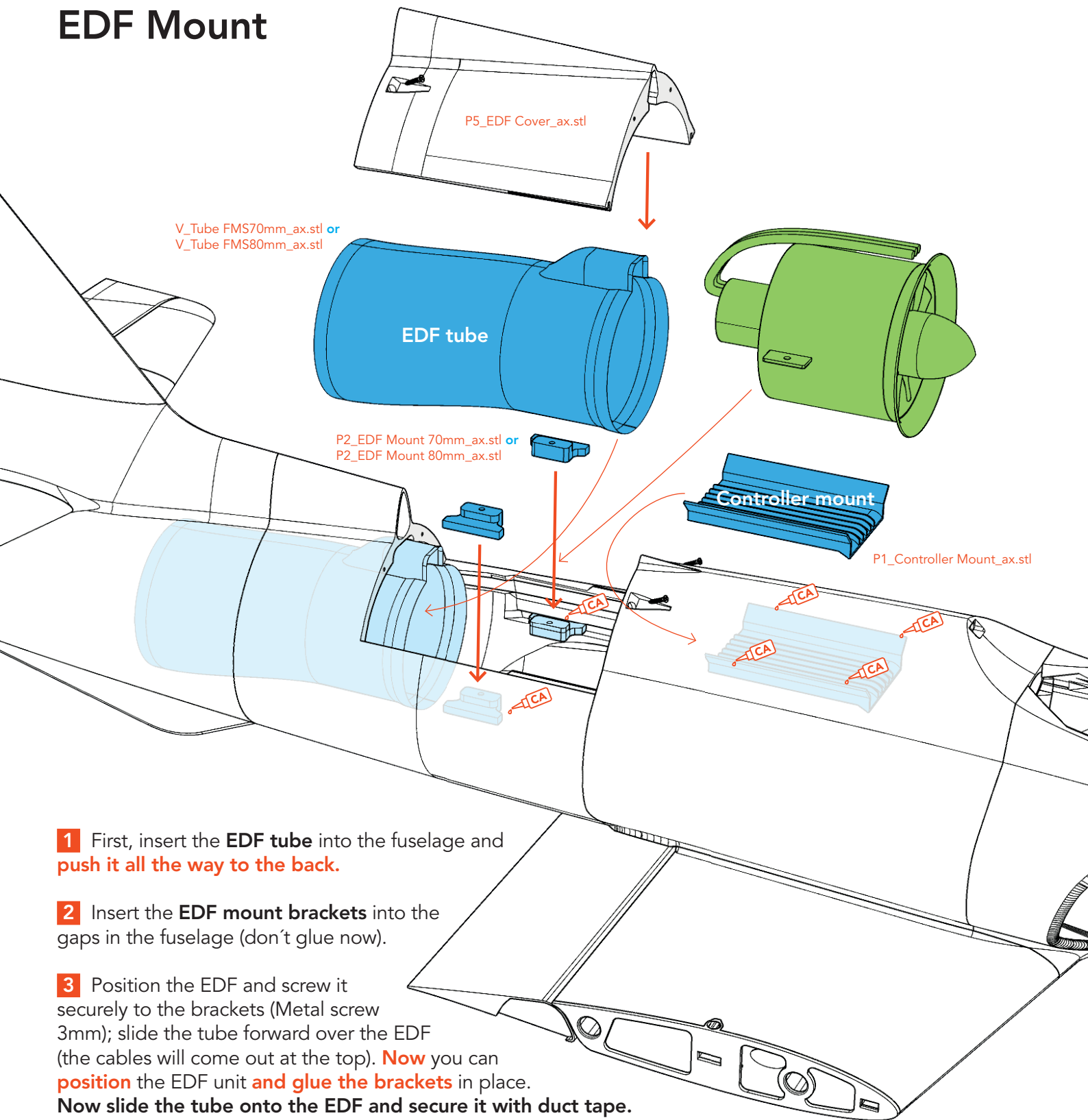

1 First, insert the **EDF tube** into the fuselage and **push it all the way to the back**.

2 Insert the **EDF mount brackets** into the gaps in the fuselage (don't glue now).

3 Position the EDF and screw it securely to the brackets (Metal screw 3mm); slide the tube forward over the EDF (the cables will come out at the top). **Now** you can **position** the EDF unit **and glue the brackets** in place. **Now slide the tube onto the EDF and secure it with duct tape.**

4 Reassemble the EDF and connect the controller. The controller is secured to the top inside of FUS 4 using the controller mount. Before attaching it, check to see what the optimal position is based on the cable length.

5 Secure the EDF cover with 4 tapping screws.

Exhaust nozzle – screw-on **PLANEPRINT Innovation**

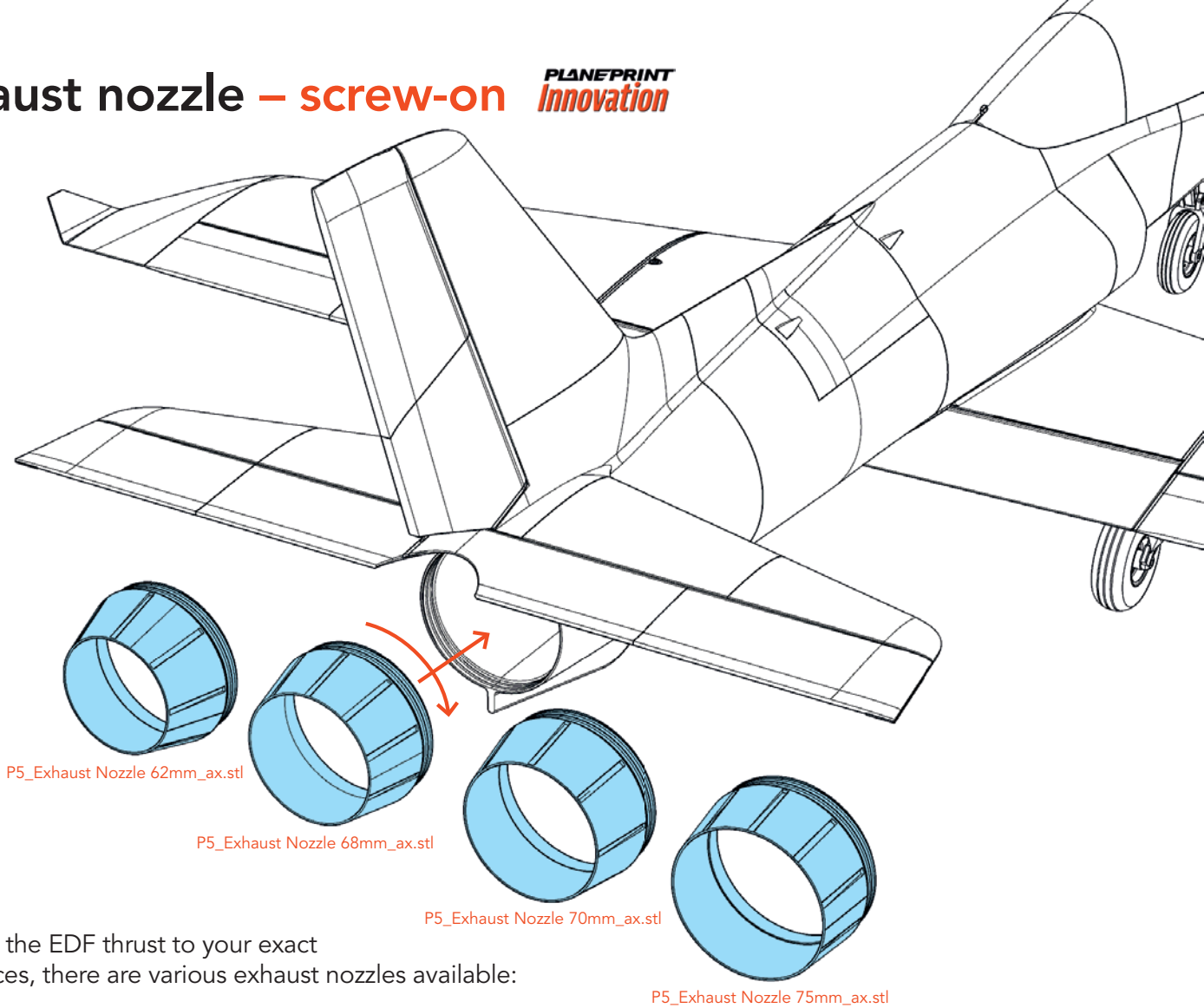

To adjust the EDF thrust to your exact preferences, there are various exhaust nozzles available:

70 mm EDF

Nozzle 68 mm	maximum takeoff thrust	lower top speed
Nozzle 62 mm	lower takeoff thrust	higher top speed

80 mm EDF

Nozzle 75 mm	maximum takeoff thrust	lower top speed
Nozzle 72 mm	lower takeoff thrust	higher top speed

Canopy assembly

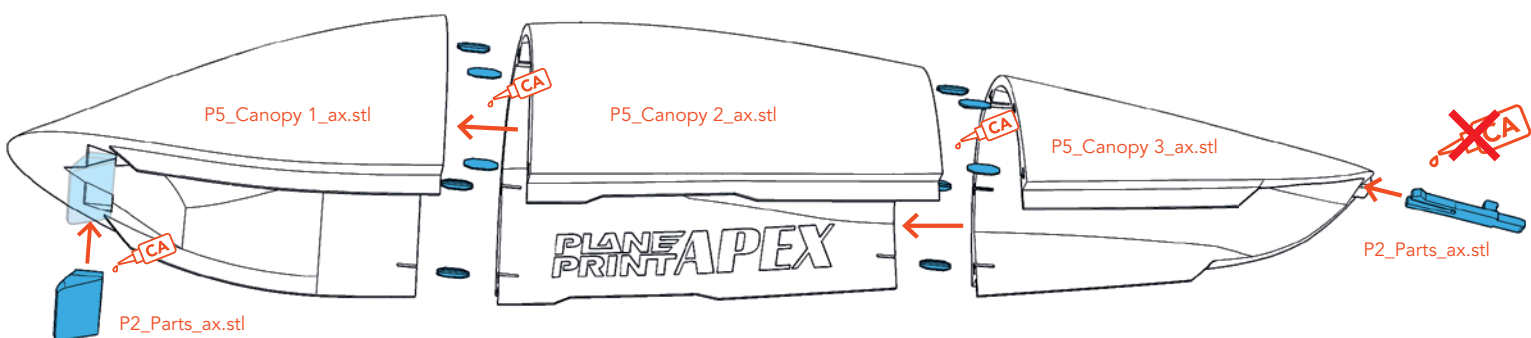

Spring-loaded Nose Gear

PLANEPRINT
Innovation

Secure this screws with a drop of medium CA glue.

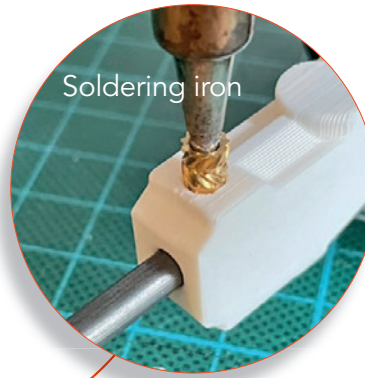

Soldering iron

Threaded inserts

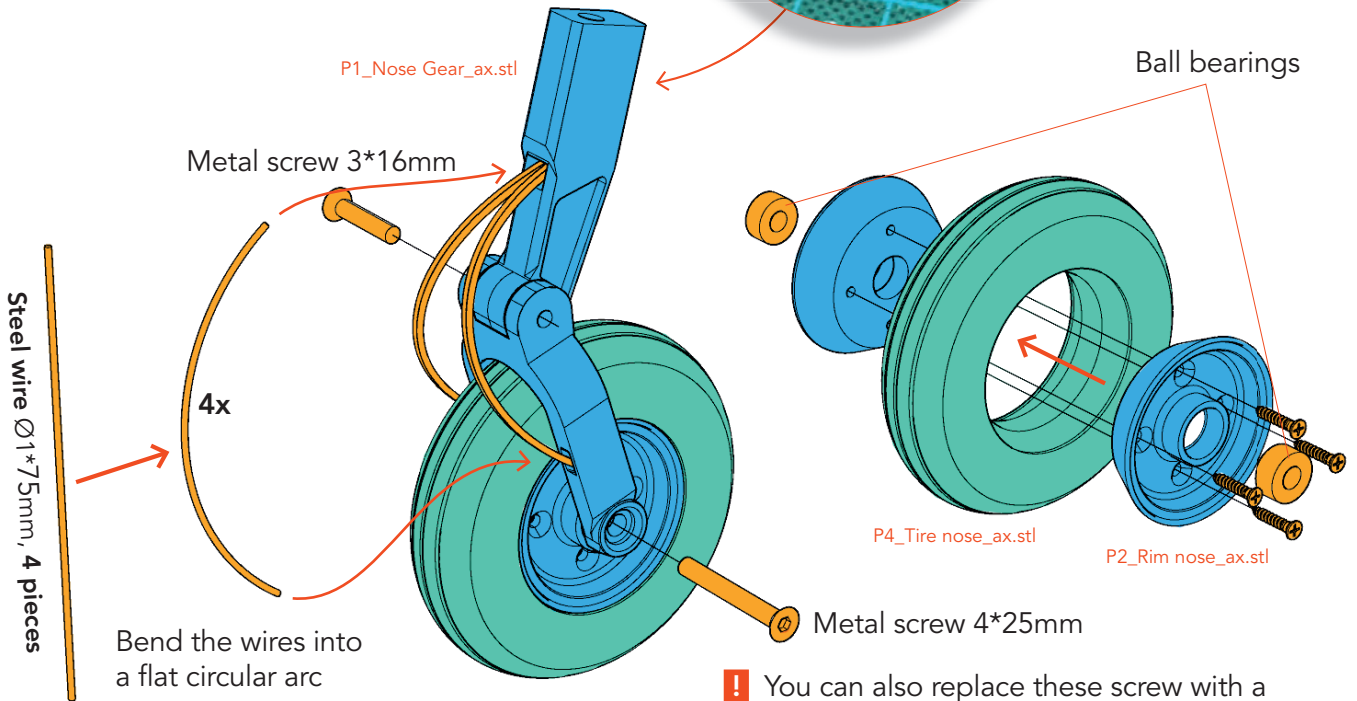

P1_Nose Gear_ax.stl

Metal screw 3*16mm

Ball bearings

Steel wire Ø1*75mm, 4 pieces

4x

Bend the wires into a flat circular arc

P4_Tire nose_ax.stl

P2_Rim nose_ax.stl

Metal screw 4*25mm

! You can also replace these screw with a 4mm-diameter carbon rod or steel wire and secure them with adhesive.

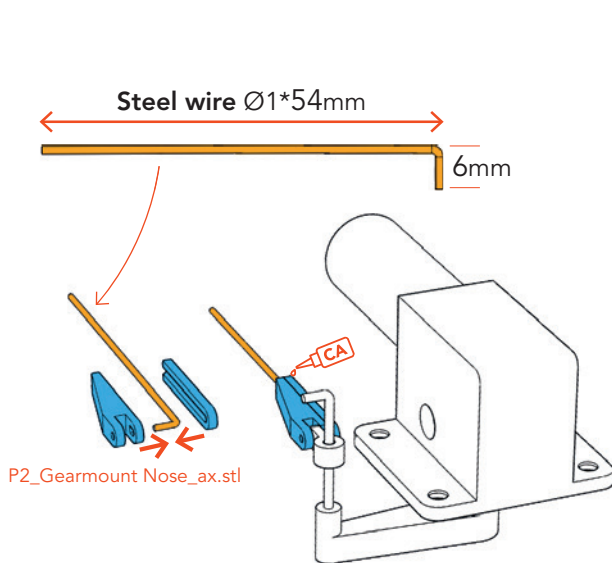

Steel wire Ø1*54mm

6mm

P2_Gearmount Nose_ax.stl

! Attach the retract mechanism to the wire before gluing it!

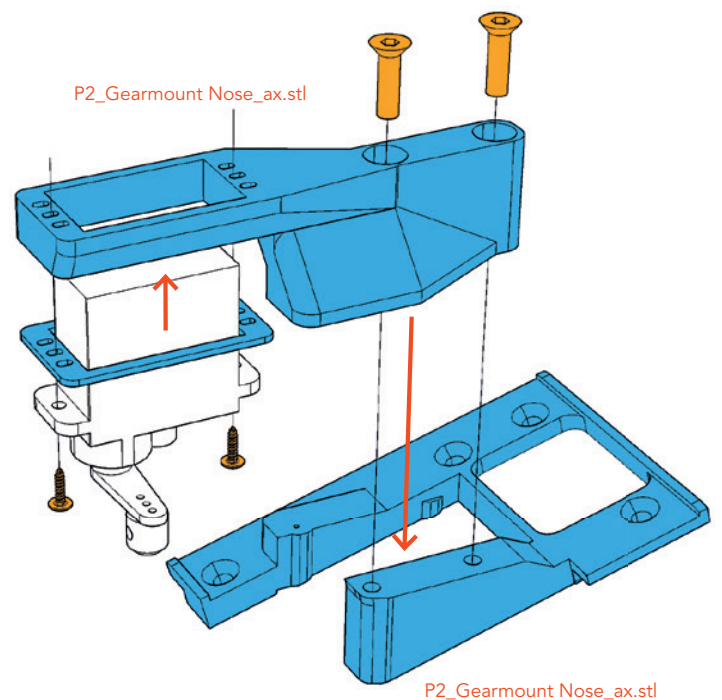

P2_Gearmount Nose_ax.stl

P2_Gearmount Nose_ax.stl

Spring-loaded Nose Gear

The gear mount parts are clamped onto the carbon tubes using 3mm metal screws – they are **not glued** on! This makes it possible to replace them in case of damage.

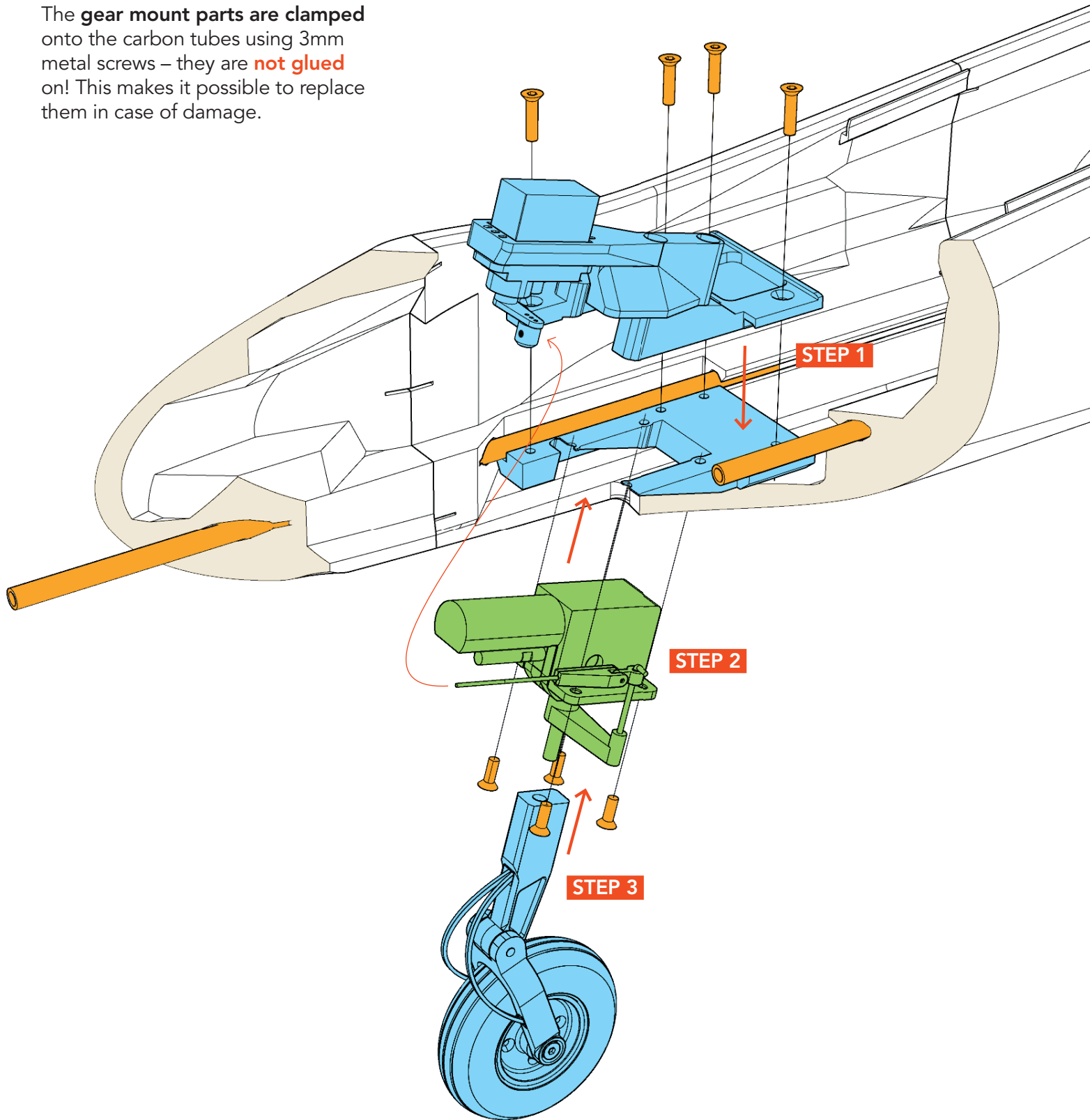

Spring-loaded Main Gear

LEFT GEAR

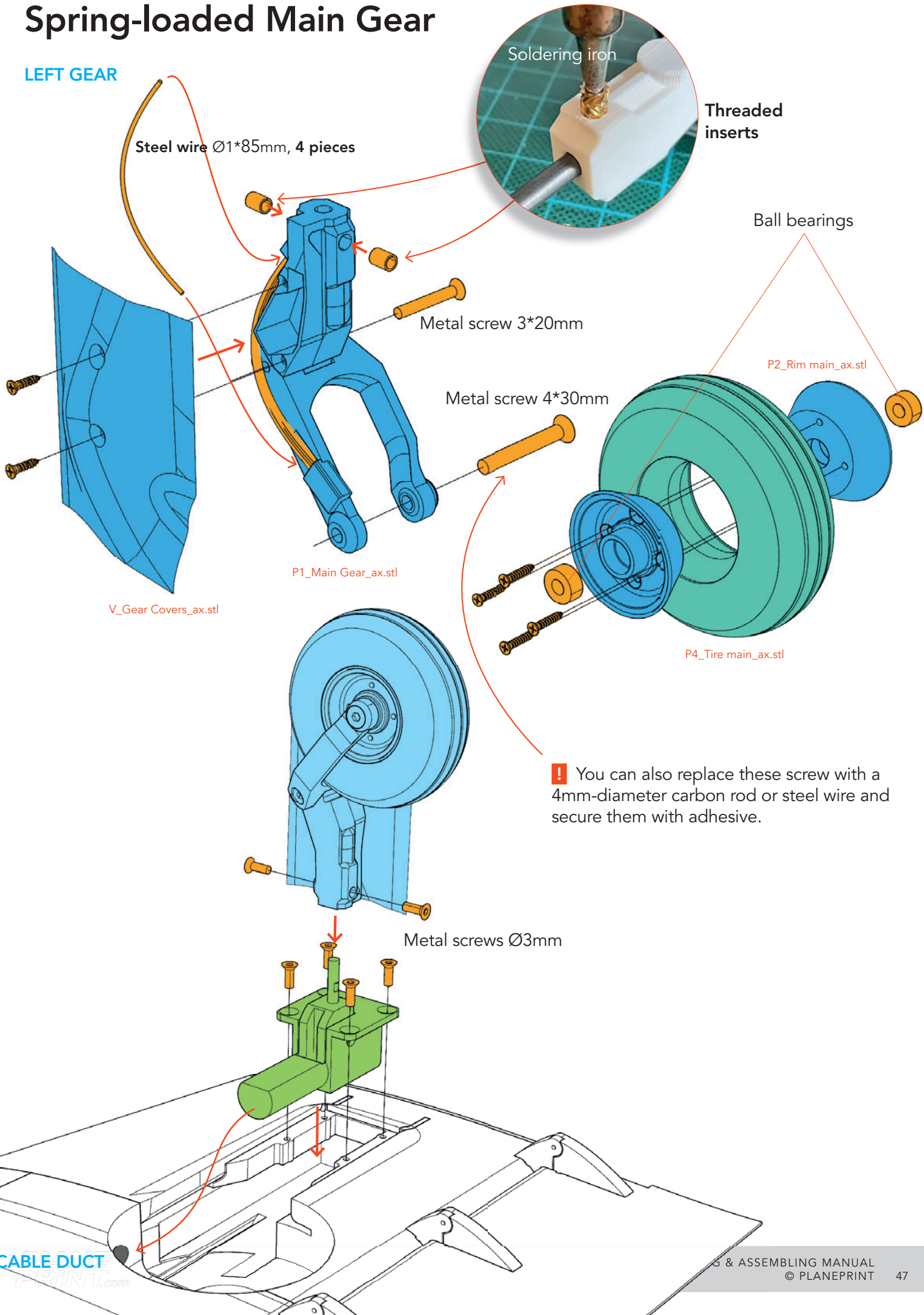

RC components

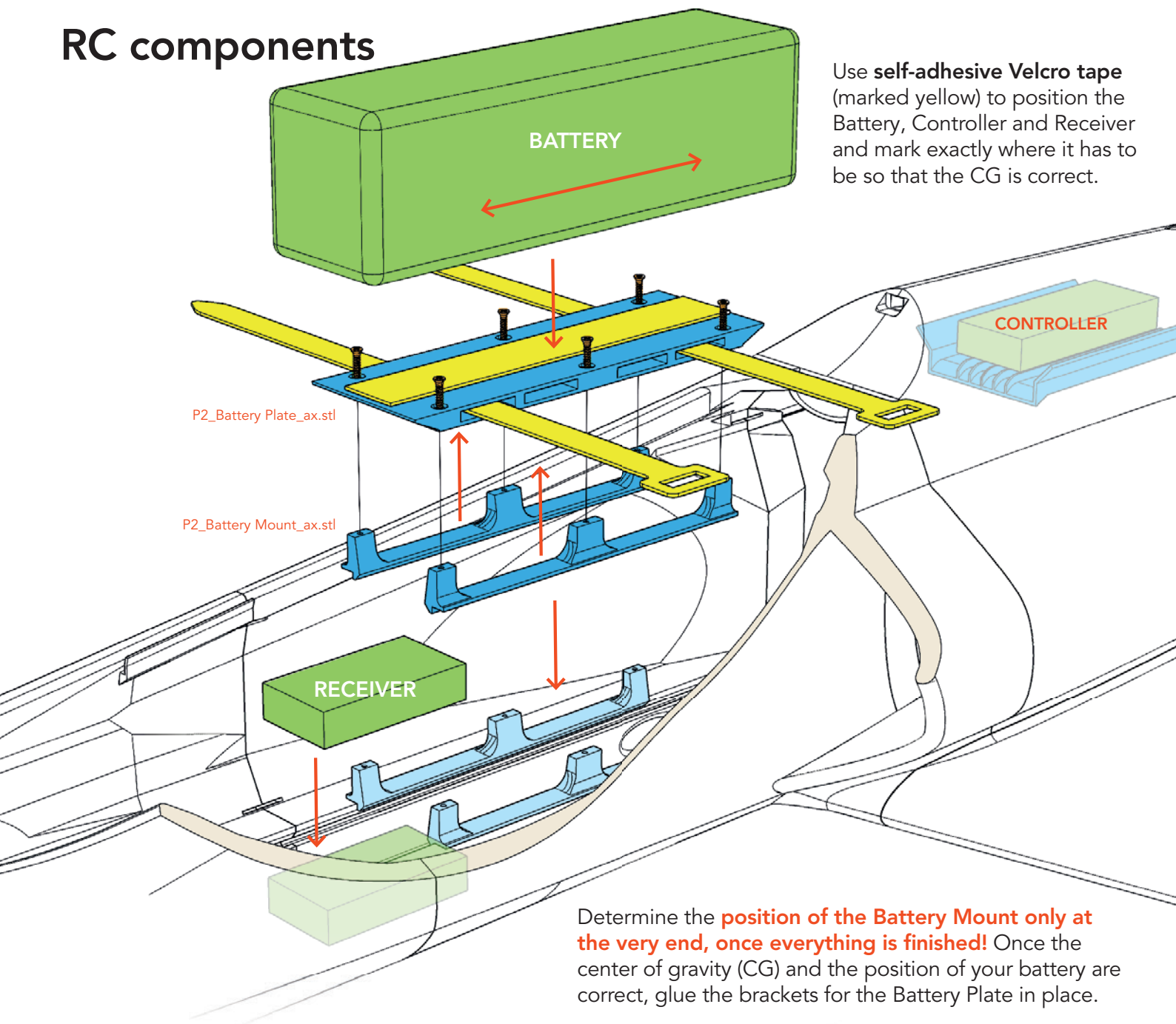

Use **self-adhesive Velcro tape** (marked yellow) to position the Battery, Controller and Receiver and mark exactly where it has to be so that the CG is correct.

Determine the **position of the Battery Mount only at the very end, once everything is finished!** Once the center of gravity (CG) and the position of your battery are correct, glue the brackets for the Battery Plate in place.

Center of Gravity (CG)

The aircraft must balance on these point – **see the marking on the fuselage.**

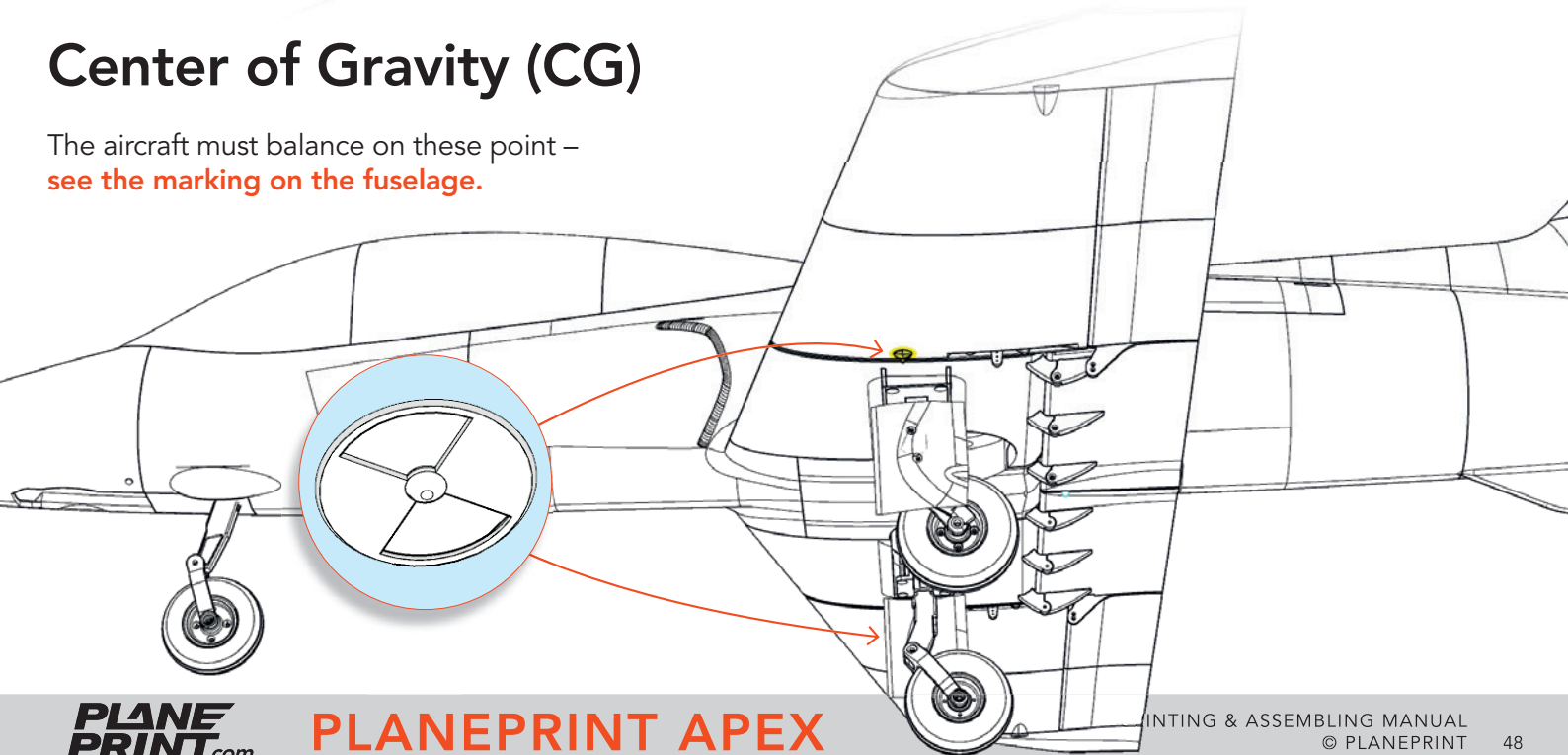

Technical specifications

PLANEPRINT APEX

WINGSPAN 1150 mm/44 inches

LENGTH 1363 mm/53.7 inches

FLIGHT WEIGHT 2450 grams (FMS70/3300mAh 6S)

WING LOAD 84 g/dm²

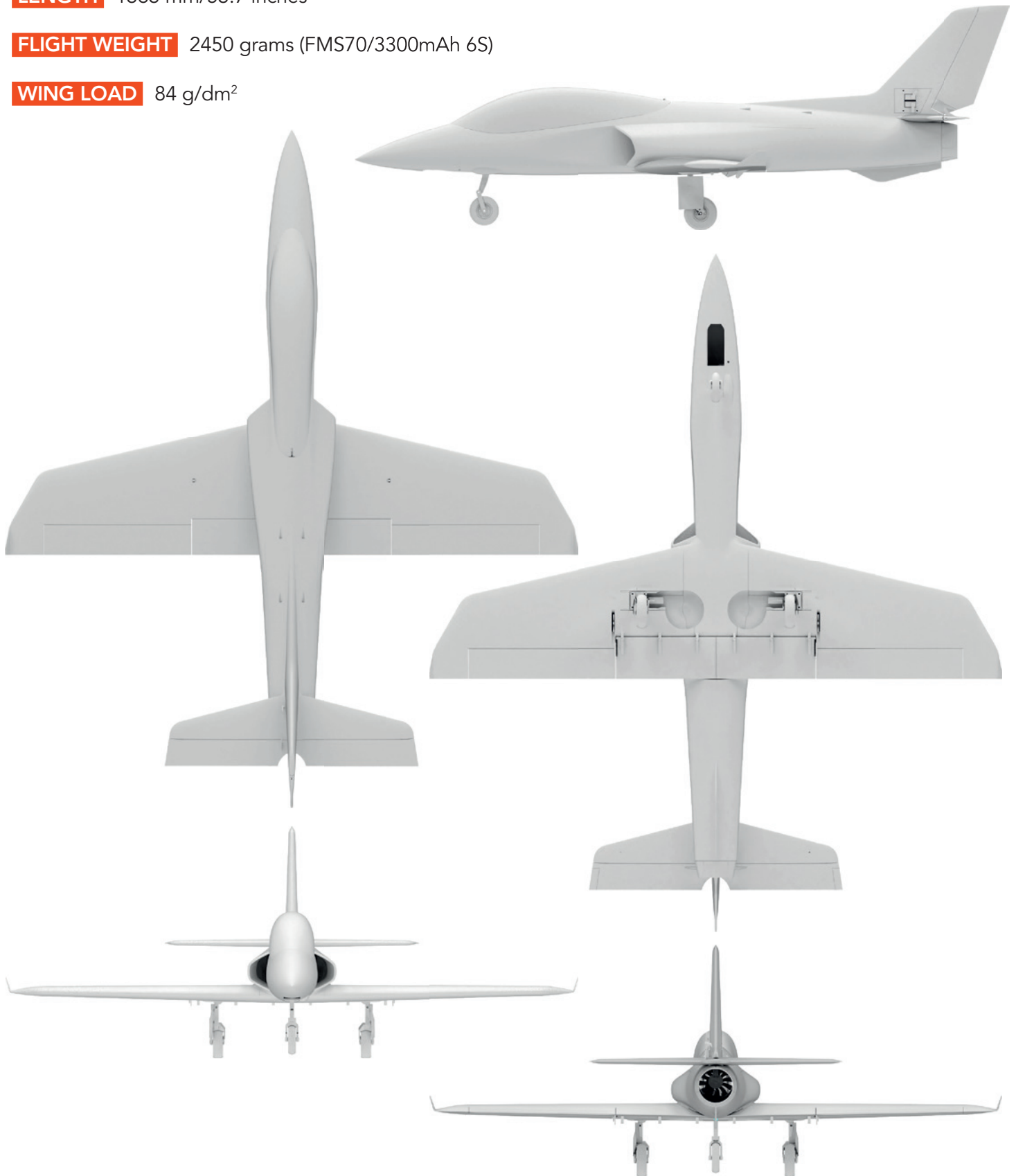

Control Direction Test Look at the aircraft from behind

ELEVATOR

15 mm up
15 mm down

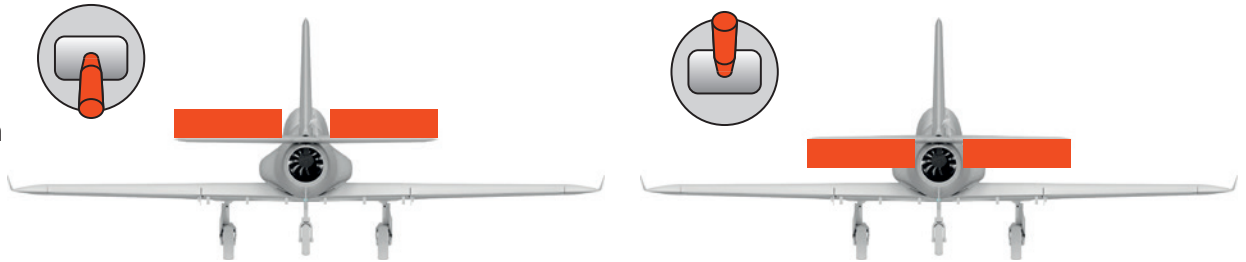

AILERON

16 mm up
12 mm down

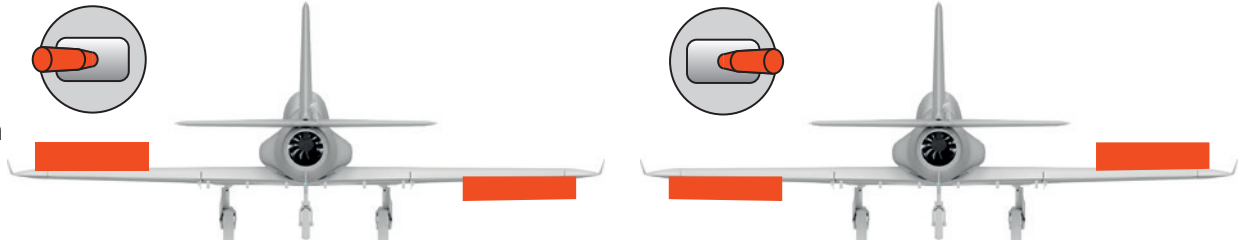

RUDDER

22 mm left
22 mm right

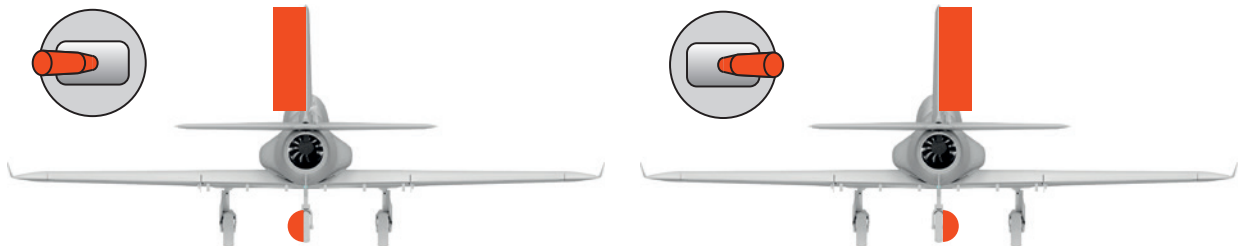

Mix the front wheel servo to the rudder channel. **IMPORTANT** Be sure to check that the **nose gear servo doesn't hit its limit when the gear is retracted** when you're giving rudder commands! If your transmitter allows it, program it so that it only moves with the rudder when the gear is extended (logic switches).

PRO TIP Set up **flight modes** for your flap positions. The advantage is that you can dial in the correct **elevator trim compensation** for both flap settings right during the maiden flight."

FLAPS

Normal

Start, slow flight

Landing

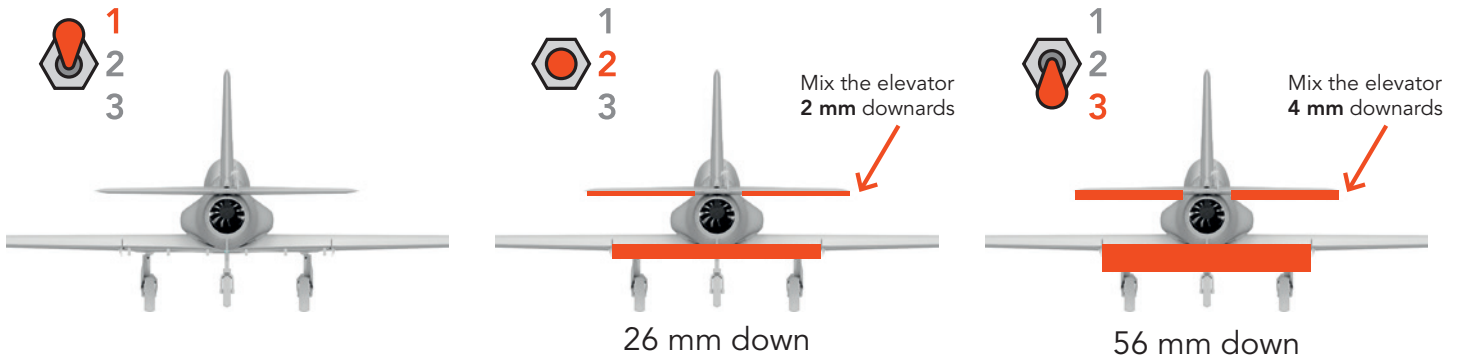

NOTE These flap positions are just a suggestion; technically, the flaps can be extended further, but this is only recommended for people who know what they're doing.

EXPO

ELEVATOR 40 %

AILERON 40 %

RUDDER 30 %

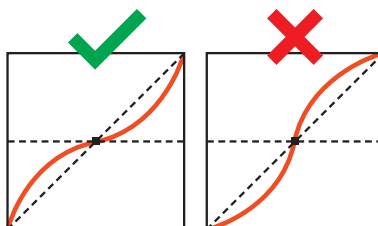

(for some remote controls a minus has to be in front of the number)

AGE RECOMMENDATION 14+

NOT FOR CHILDREN UNDER 14 YEARS. THIS IS NOT A TOY!

The STL data (or data processed from it, such as G codes) must never be passed on to third parties!

The purchase of the STL does not authorize the production of models for third parties.

By using the download data, an RC model airplane, called „model“ for short, can be manufactured using a 3D printer. As a user of this model, only you are responsible for safe operation that does not endanger you or others, or that does not damage the model or property of others.

PLANEPRINT.com assumes no responsibility for damage to persons and property caused by pressure, transport or use of the product. Filaments, printing supplies, hardware or consumables that can not be used after faulty 3D printing will not be replaced by PLANEPRINT.com in any way.

When operating, always keep a safe distance from your model in all directions to avoid collisions and injuries.

This model is controlled by a radio signal. Radio signals can be disturbed from outside without being able to influence it. Interference can lead to a temporary loss of control.

Always operate your model on open terrains, far from cars, traffic and people.

Always follow the instructions and warnings for this product and any optional accessories (servos, receivers, motors, propellers, chargers, rechargeable batteries, etc.) carefully.

Keep all chemicals, small parts and electrical components out of the reach of children.

Avoid water contact with all components that are not specially designed and protected. Moisture damages the electronics.

Never take an item of the model or accessory in your mouth as this can lead to severe injuries or even death.

Never operate your model with low batteries in the transmitter or model.

Always keep the model in view and under control.
Use only fully charged batteries.

Always keep the transmitter switched on when the model is switched on.

Always remove the battery before disassembling the model.

Keep moving parts clean and dry at all times.

Always allow the parts to cool before touching them.

Always remove the battery after use.

Make sure that the Failsafe is properly set before the flight.

Never operate the model with damaged wiring.

Never touch moving parts.

We develop our models to the best of our knowledge and belief.
We accept no liability for consequential damage and injuries caused by improper use or incorrectly printed parts. **Please be careful when handling motors, batteries and propellers** and only move your model with insurance and in approved places!

PLANE PRINT