

# SHARD



**NOTE:** Slicing only works with CURA!



You can find the STL data at [www.planeprint.com](http://www.planeprint.com)

# Printing the parts – Printing profiles

This manual is constantly being improved and supplemented, we recommend downloading the **latest version** from our website **before building**.

For slicing all Planeprint models, these profiles have to be created in Cura:

PROFILE P1\_fullbody  
PROFILE P2\_hollowbody  
PROFILE P3\_surface  
PROFILE P4\_flex  
PROFILE P5\_gyroid

You can find the description at [www.planepprint.com/print](http://www.planepprint.com/print)

## Important for the 1-wall-print (P3, P5)!

In order to print airfoils of the lowest possible weight with high stability, it is necessary to print with only one wall line (Nozzle 0.4 mm). Decisive here is the adhesion between the layers! To achieve this, you must print at a much higher temperature than normal. As a **guideline**, 230° C is a good starting point. The parts-cooling fan should be set to 0% or a maximum of 20%. Since not every printer works the same, it may be necessary to make small adjustments to these settings.

Here we show you how to make adjustments from a standard CURA profile.

**For this model we need only 3 (P1, P4, P5), easy to create profiles.**

For the new PROFILE P5\_gyroid it is essential to use **Cura Version 5 or later**, It will work with older versions, but the weight of the parts will be higher and the printing time longer.

It is **essential for the necessary stability** of the SHARD that the **LW parts printed with PROFILE\_5 are as stable as possible**. Please use a test part to check the strength by fracture tests. It must not break along the layer lines under any circumstances! Also note that the printing temperature for LW-PLA is as low as possible to obtain a wall thickness of 0.4 to 0.6 mm at a flow of 65%. **At too high temperatures, LW-PLA becomes brittle and breaks more easily.**



The development of a complex, airworthy RC flight model to express on any standard 3D printer is a very complex and extensive process. Therefore, we appeal to your fairness not to forward the STL data you have acquired to third parties. Our STL files are provided with indelible copyright watermarks that can be verified at any time.

**Thank you for your understanding and have fun with your PLANEPRINT MODEL!**

# PROFILE P1\_FULLBODY PLA or better Tough PLA

The following parts must be sliced with the PROFILE P1\_FULLBODY.  
Please note the additional settings for the individual parts!

## Cooling sheets\_p1\_Shard.stl

**MATERIAL** PLA or PLA+, Weight: ~ 2 g

### ADDITIONAL SETTINGS

- Z Seam Alignment: User Specified
- Z Seam Position: Back
- Built Plate Adhesion Type: Brim

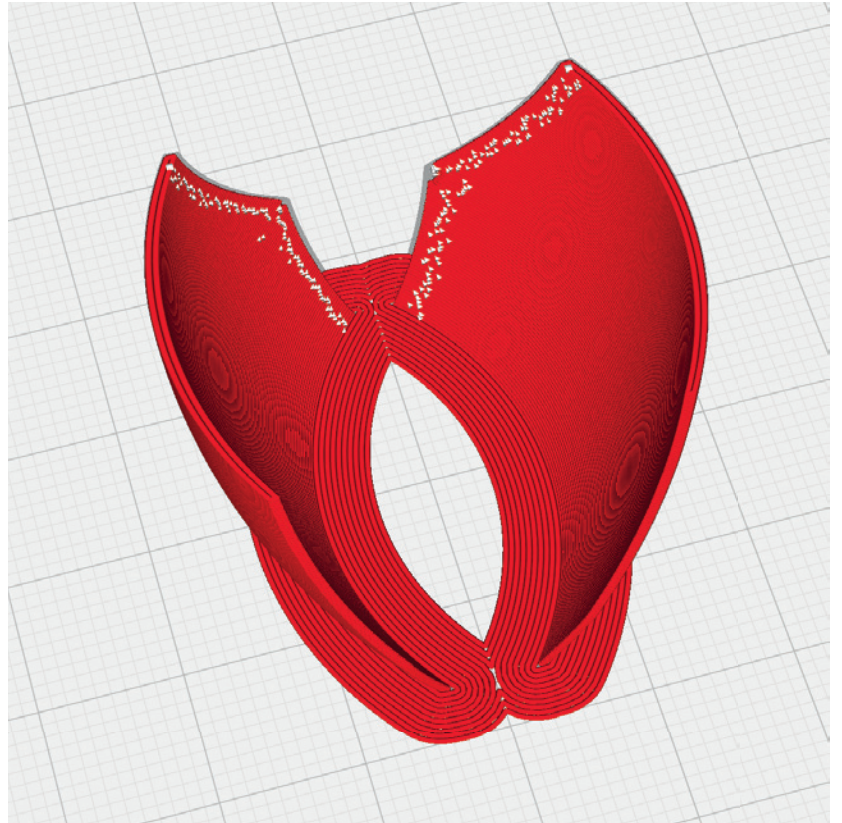

## Interconnects\_p1\_Shard.stl

**MATERIAL** LW-PLA, ~ 2 g

### ADDITIONAL SETTINGS

None required

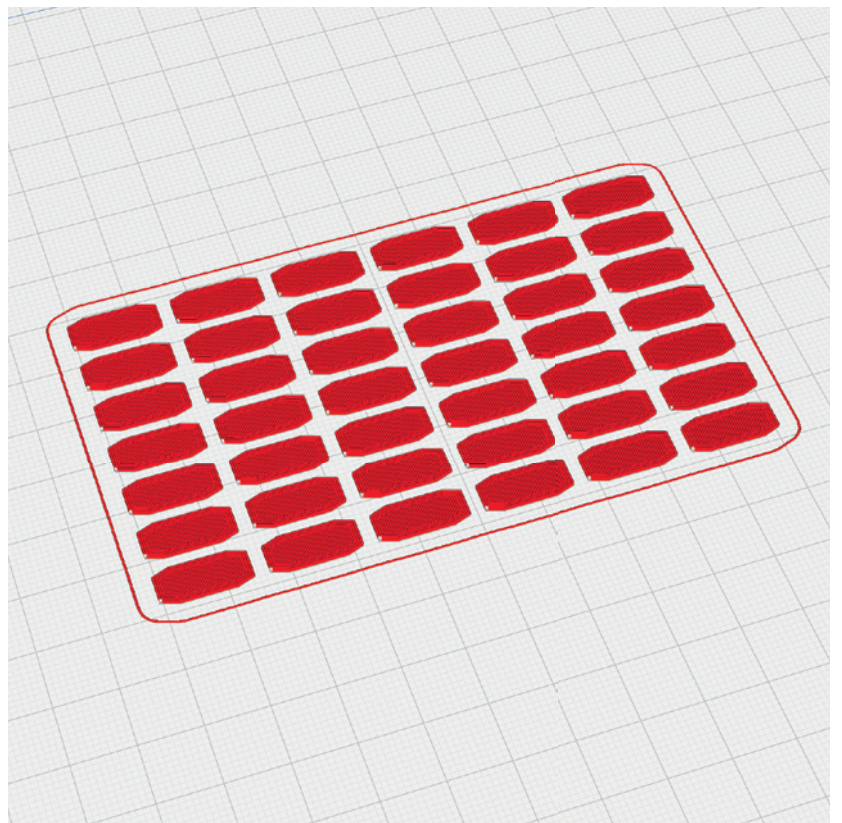



# PROFILE P1\_FULLBODY PLA or better Tough PLA

The following parts must be sliced with the PROFILE P1\_FULLBODY.  
Please note the additional settings for the individual parts!

## Motor tool\_p1\_Shard.stl

**MATERIAL** PLA or PLA+, Weight: ~ 6 g

### ADDITIONAL SETTINGS

None required

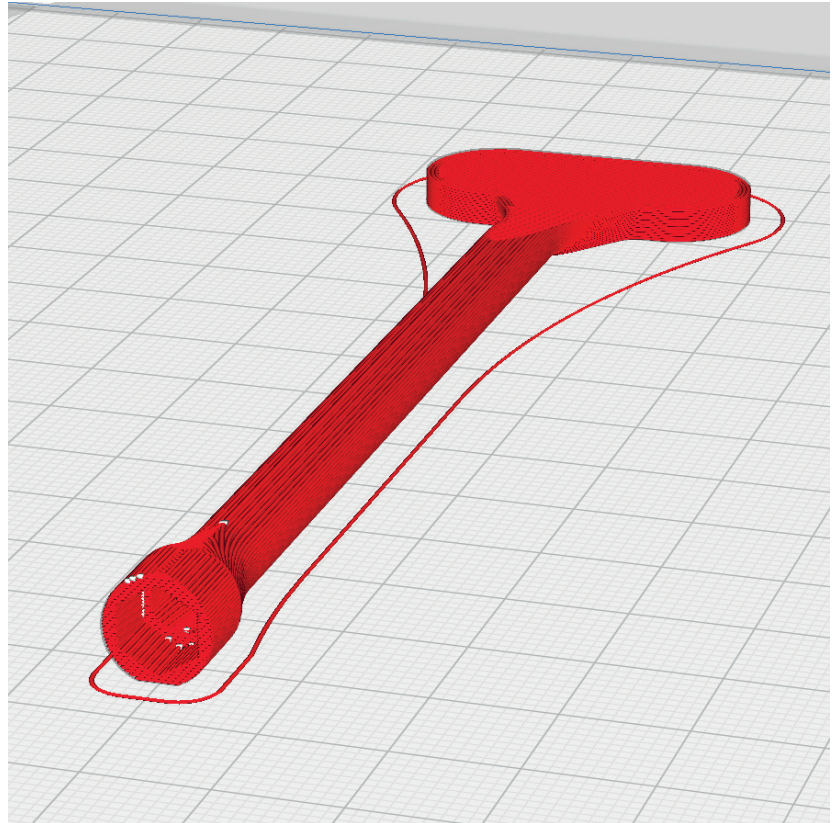

## Motormount 43mm\_p1\_Shard.stl

**MATERIAL** PLA or PLA+, ~ 18 g

You can also print this part with ABS or PETG,  
the more heat resistant the better.

### ADDITIONAL SETTINGS

None required

In the optional parts folder you will find a variant with **48 mm** hole spacing, if your motor has a larger cross with it. In this variant, the space for installation is very tight, possibly something must be filed off at the cross.

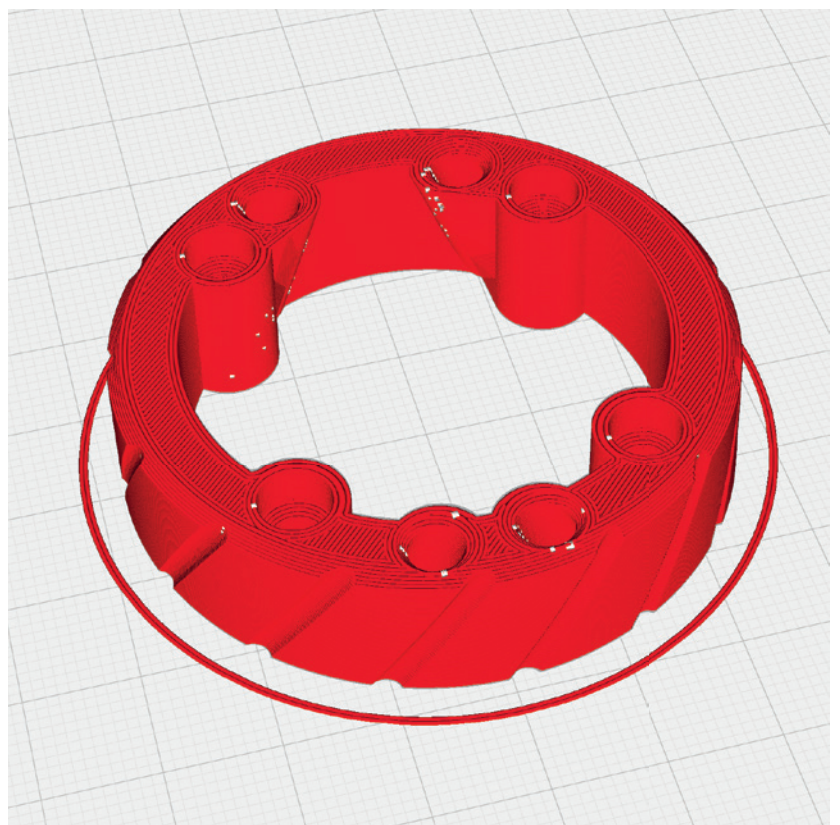



# PROFILE P1\_FULLBODY PLA or better Tough PLA

The following parts must be sliced with the PROFILE P1\_FULLBODY.  
Please note the additional settings for the individual parts!

## Mount battery\_p1\_Shard.stl

**MATERIAL** PLA or PLA+, Weight: ~ 8 g

### ADDITIONAL SETTINGS

None required

- Print this part twice

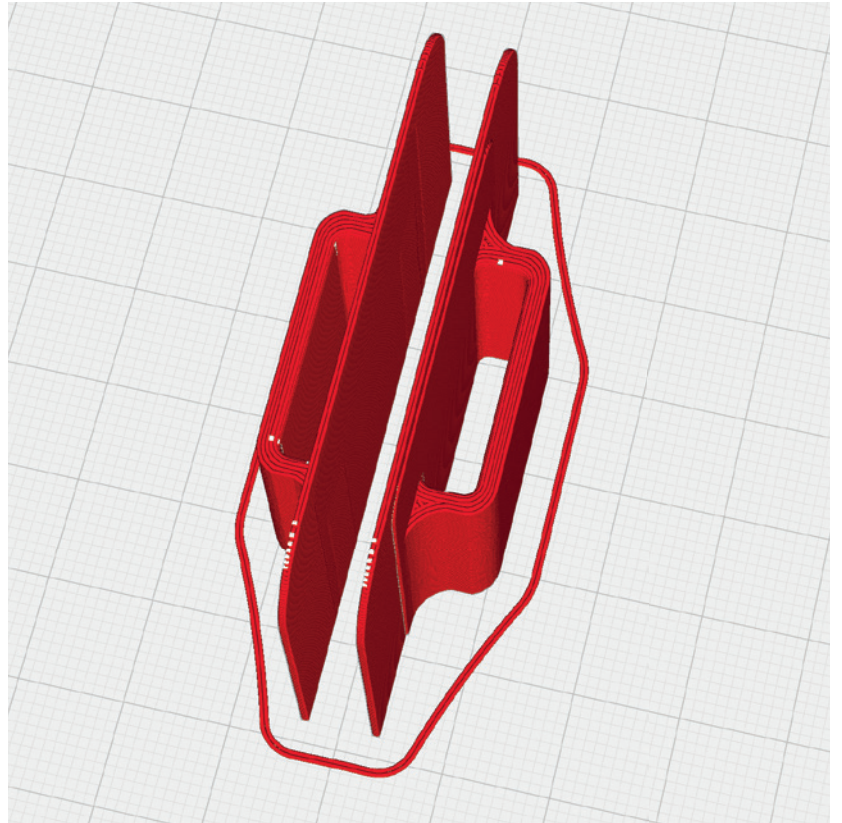

## Mount rc\_p1\_Shard.stl

**MATERIAL** PLA or PLA+, ~ 9 g

### ADDITIONAL SETTINGS

None required



# PROFILE P1\_FULLBODY PLA or better Tough PLA

The following parts must be sliced with the PROFILE P1\_FULLBODY.  
Please note the additional settings for the individual parts!

## Parts 1\_p1\_Shard.stl

**MATERIAL** PLA or PLA+, Weight: ~ 16 g

### ADDITIONAL SETTINGS

None required

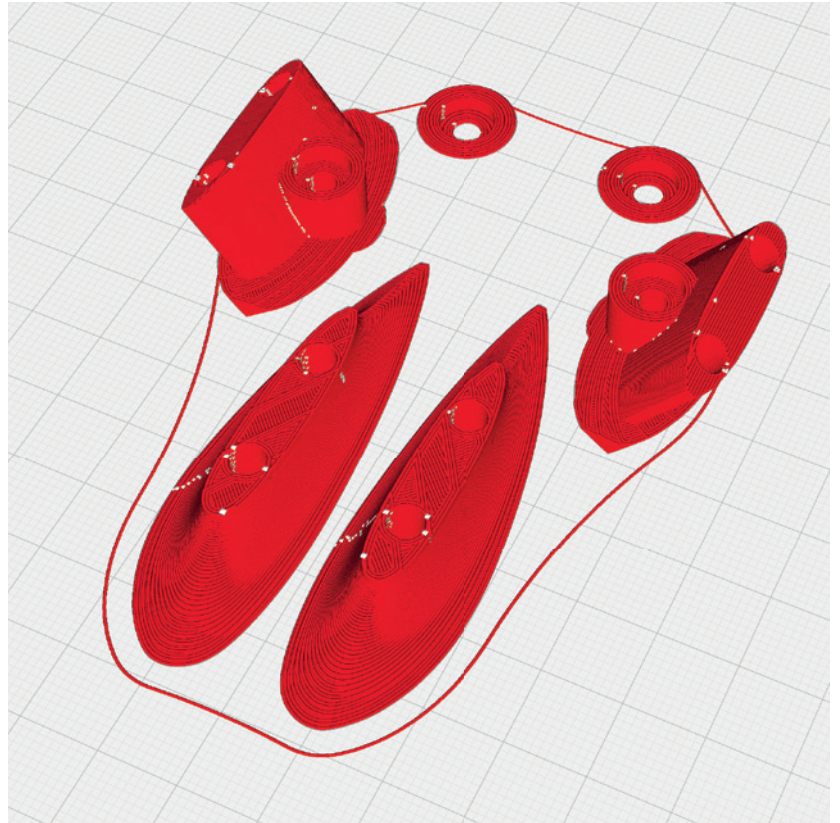

## Parts 2\_p1\_Shard.stl

**MATERIAL** PLA or PLA+, ~ 12 g

### ADDITIONAL SETTINGS

None required





# PROFILE P1\_FULLBODY PLA or better Tough PLA

The following parts must be sliced with the PROFILE P1\_FULLBODY.  
Please note the additional settings for the individual parts!

## Parts 3\_p1\_Shard.stl

**MATERIAL** PLA or PLA+, Weight: ~ 20 g

### ADDITIONAL SETTINGS

None required

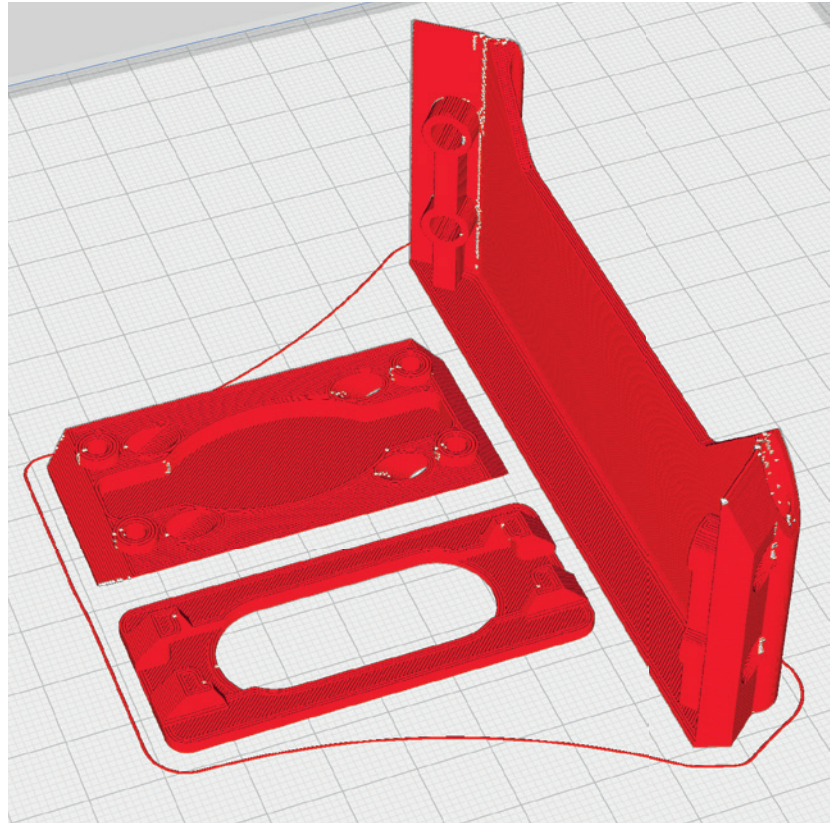

## Parts 4\_p1\_Shard.stl

**MATERIAL** PLA or PLA+, ~ 5 g

### ADDITIONAL SETTINGS

None required

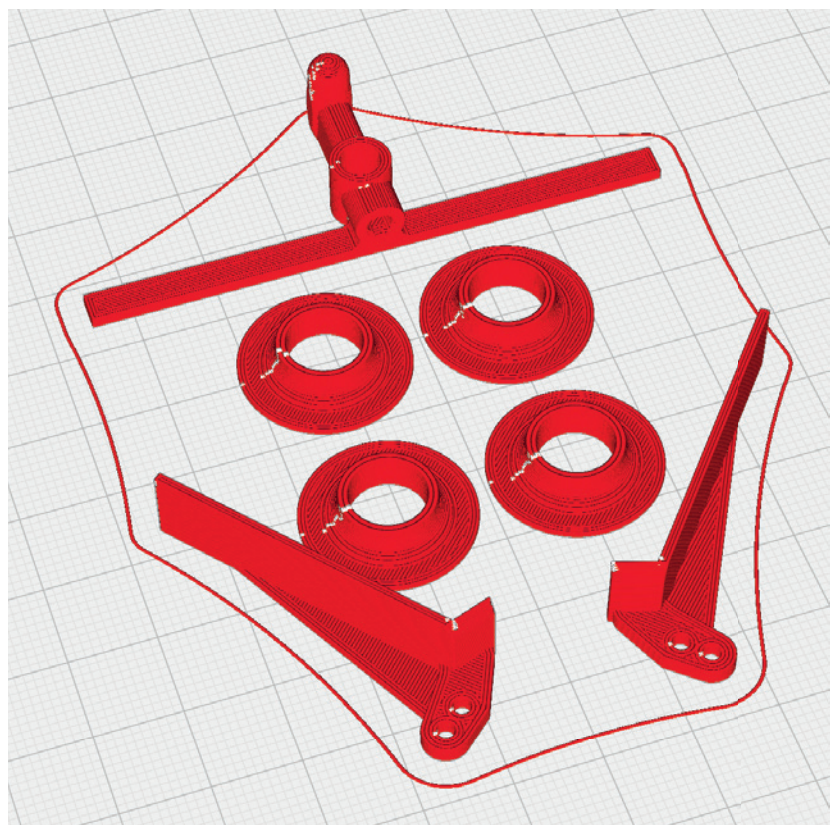



# PROFILE P1\_FULLBODY PLA or better Tough PLA

The following parts must be sliced with the PROFILE P1\_FULLBODY.  
Please note the additional settings for the individual parts!

## Rim\_p1\_Shard.stl

**MATERIAL** PLA or PLA+, Weight: ~ 5 g

### ADDITIONAL SETTINGS

None required

- Print this part twice

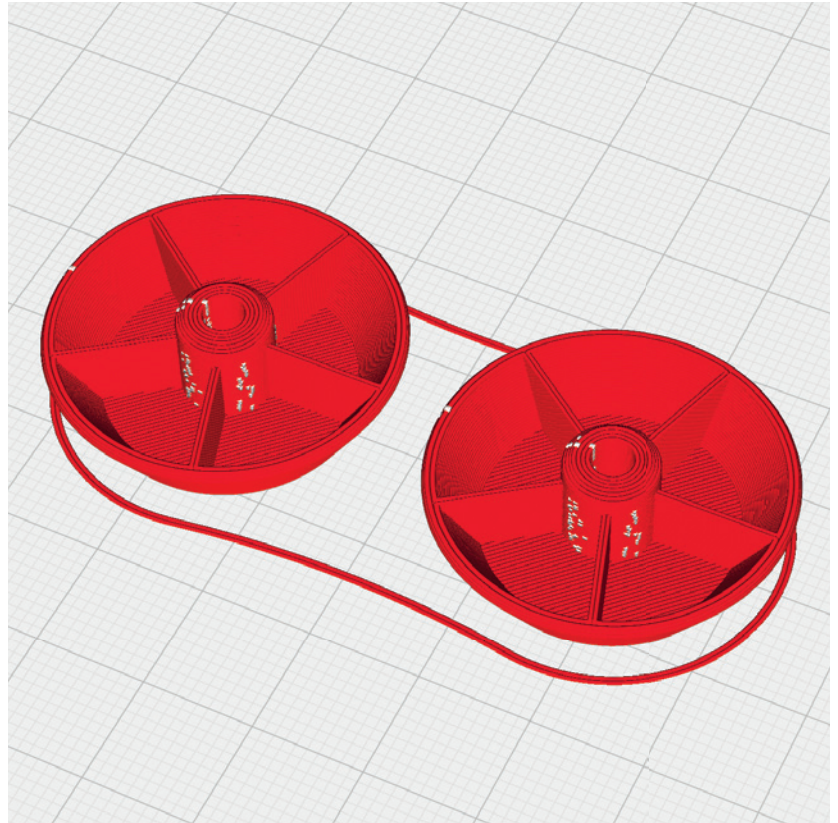

## Servo brackets\_p1\_Shard.stl

**MATERIAL** PLA or PLA+, ~ 13 g

### ADDITIONAL SETTINGS

None required

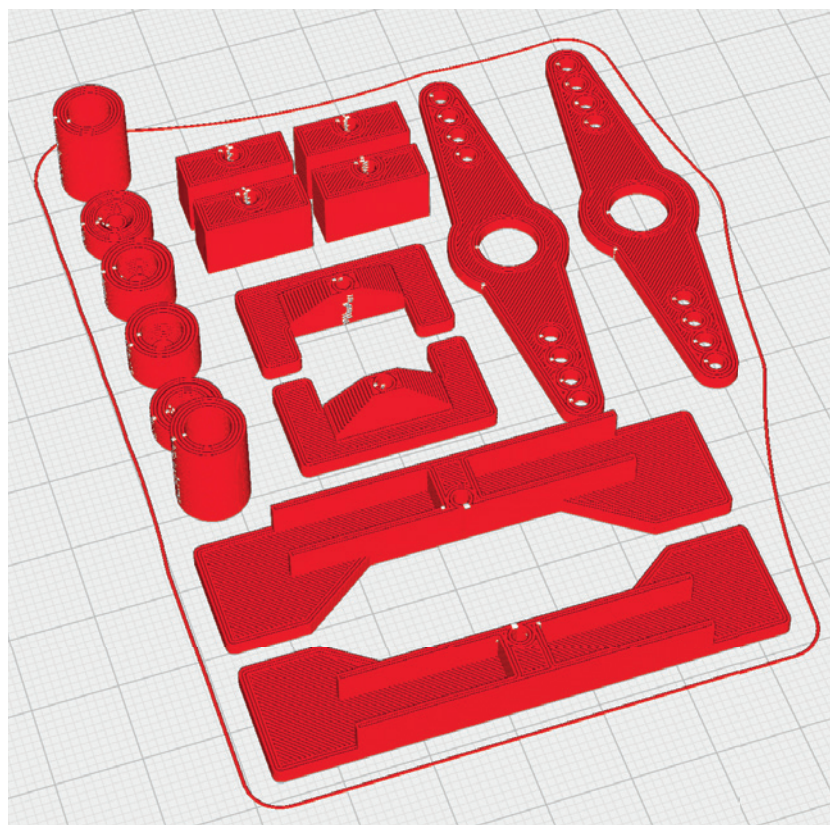



# PROFILE P1\_FULLBODY PLA or Tough PLA

The following parts must be sliced with the PROFILE P1\_FULLBODY.  
Please note the additional settings for the individual parts!

## Spinner plate\_p1\_Shard.stl

**MATERIAL** PLA or PLA+, ~ 6 g

### ADDITIONAL SETTINGS

None required

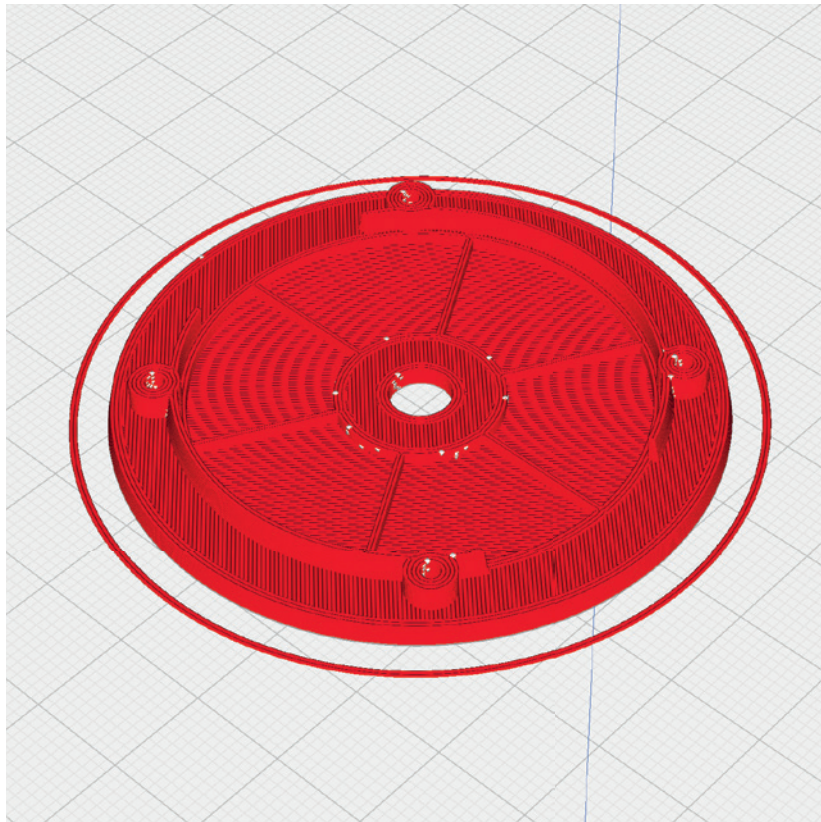

## Wing protectors\_p1\_Shard.stl

**MATERIAL** PLA or PLA+, ~ 13 g

### ADDITIONAL SETTINGS

None required

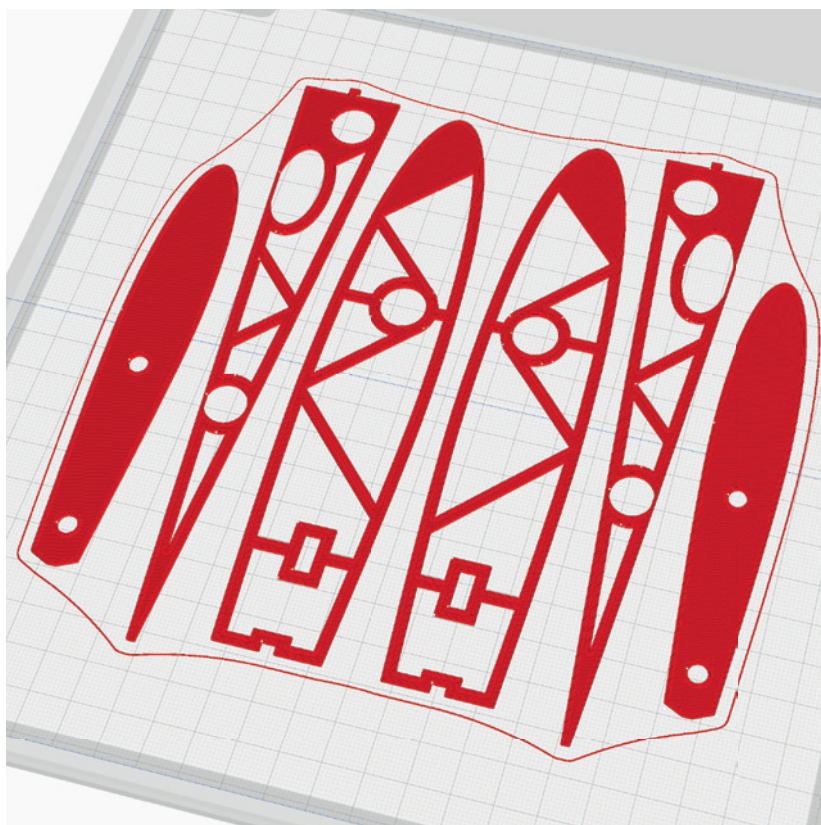



# PROFILE P4\_FLEX TPU A95 and VarioShore

The following parts must be sliced with the PROFILE P4\_FLEX.  
Please note the additional settings for the individual parts!

Tension belt VarioShore\_p4\_Shard.stl  
Tension belt TPUA95\_p4\_Shard.stl

**MATERIAL** TPU ~ A95, Weight: ~ 2 g

## ADDITIONAL SETTINGS

- Infill Density 100 %

**INFO:** the tension belt made of VarioShore LW-TPU is shorter because the material is more elastic. We recommend the variant made of VarioShore.

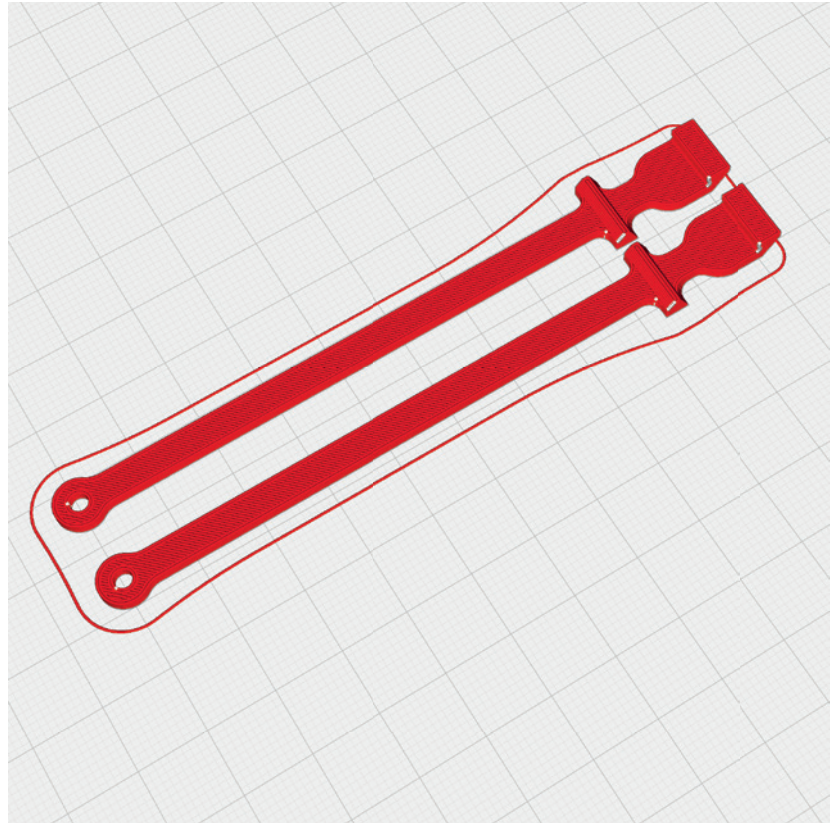

## INFO Tension belt length

If you want to change them slightly in length, you can simply change the dimension of the X-axis in Cura (Uniform scaling must NOT be selected).

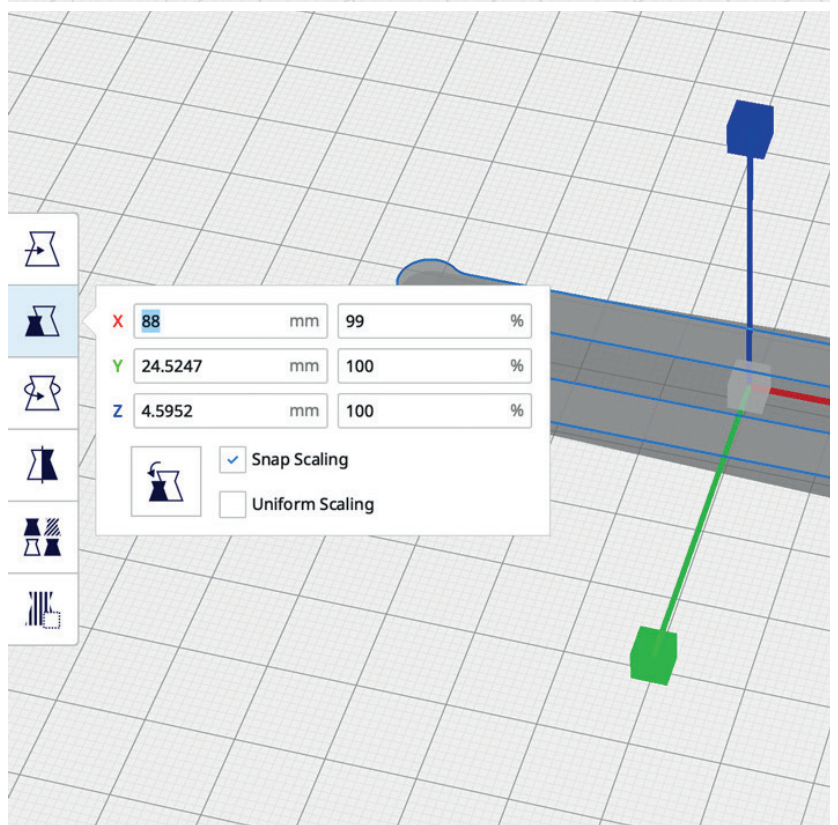



# PROFILE P4\_FLEX TPU A95 and VarioShore

The following parts must be sliced with the PROFILE P4\_FLEX.  
Please note the additional settings for the individual parts!

We recommend printing the tires with the LW-TPU VarioShore to obtain super light and soft wheels.

We print with 60% flow and 240°.

## Tire back\_p4\_Shard.stl

**MATERIAL** TPU VarioShore, Weight: ~ 1 g

### ADDITIONAL SETTINGS

- Wall Line Count: 4
- Top Layers: 3
- Bottom Layers: 3
- Infill Density: 17 %
- Infill Pattern: Grid or Gyroid

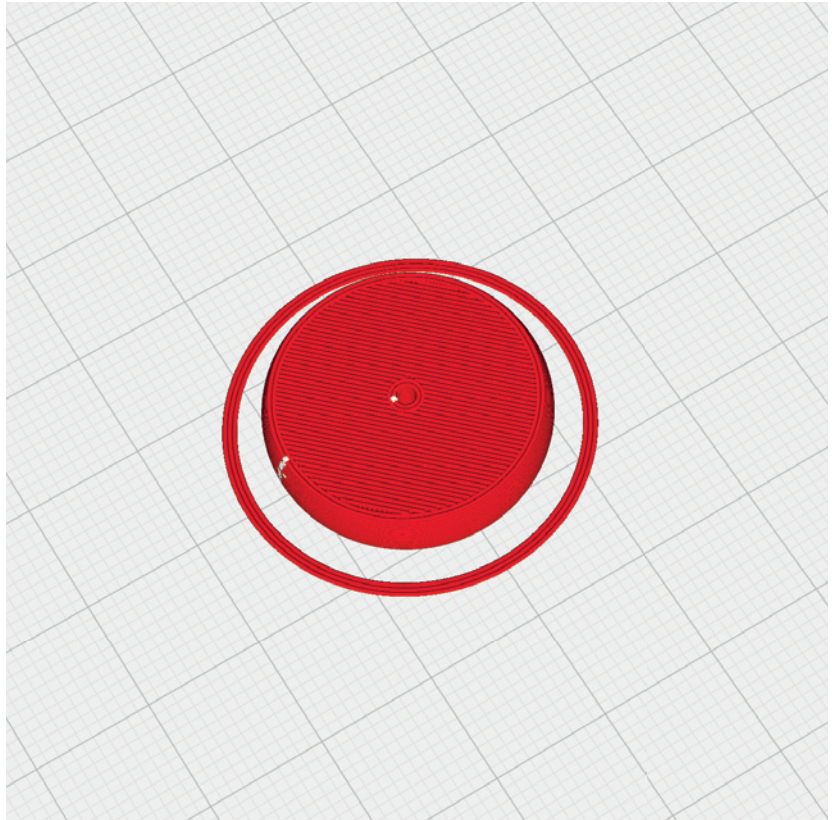

## Tire\_p4\_Shard.stl

**MATERIAL** TPU VarioShore, Weight: ~ 4 g

### ADDITIONAL SETTINGS

- Wall Line Count: 4
  - Top Layers: 4
  - Bottom Layers: 4
  - Infill Density: 17 %
  - Infill Pattern: Grid or Gyroid
- Print this part twice

View in cross-section printed with Colorfabb VarioShore LW-TPU.

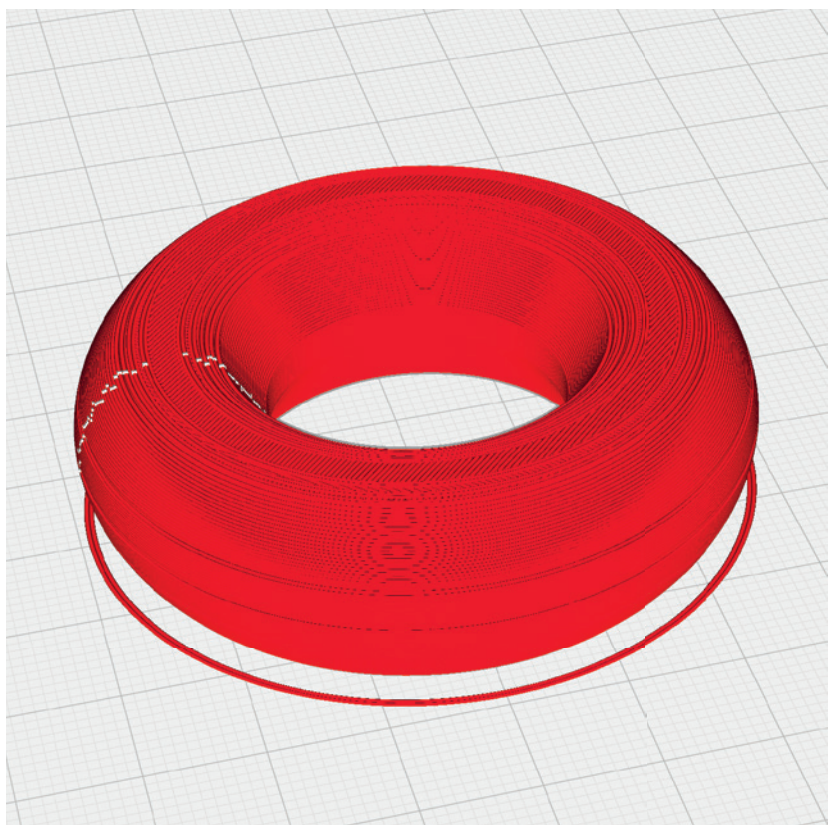

# PROFILE P4\_FLEX TPU A95 and VarioShore

The following parts must be sliced with the PROFILE P4\_FLEX.  
Please note the additional settings for the individual parts!

## Hinges\_p4\_Shard.stl

**MATERIAL** TPU VarioShore, Weight: ~ 2 g

### **ADDITIONAL SETTINGS**

None required

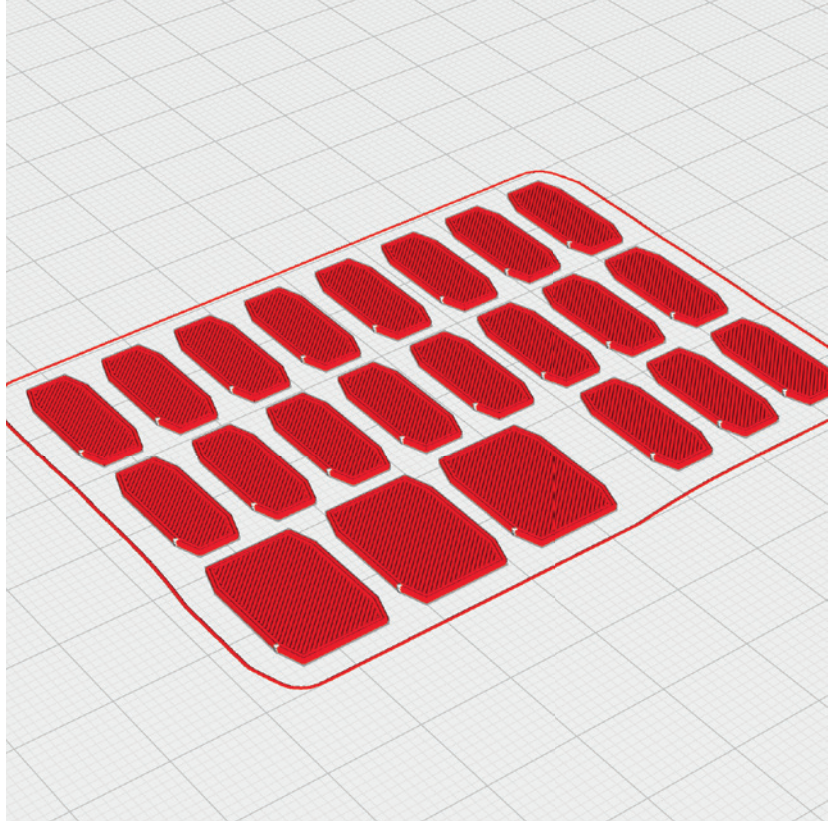



# PROFILE P5\_GYROID **Light-Weight LW-PLA!**

The following parts must be sliced with the PROFILE P5\_GYROID. **Please note the additional settings for the individual parts! It is essential to print these parts with LW-PLA!**

**Basic settings for LW-PLA:** Please follow the instructions in our **WINGTEST AND CALIBRATION TOOL** on our website for correct adjustment!

**Aileron 1 left\_p5\_Shard.stl**  
**Aileron 1 right\_p5\_Shard.stl**

**MATERIAL** LW-PLA, ~ 13 g\*

\*Weighed

**ADDITIONAL SETTINGS**

None required

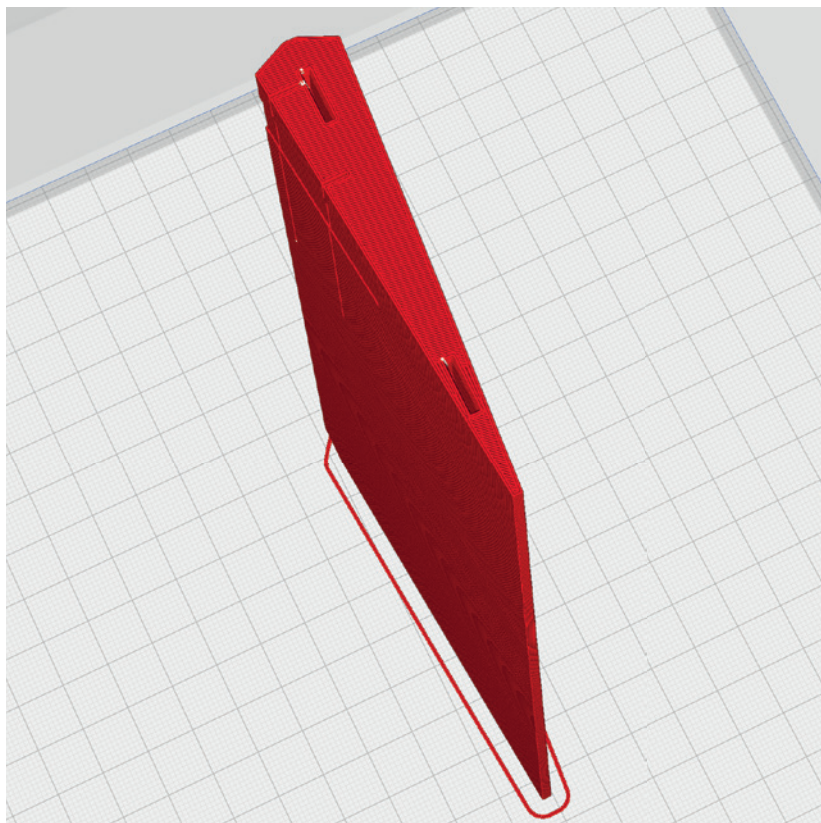

**Aileron 2 left\_p5\_Shard.stl**  
**Aileron 2 right\_p5\_Shard.stl**

**MATERIAL** LW-PLA, ~ 13 g\*

\*Weighed

**ADDITIONAL SETTINGS**

None required

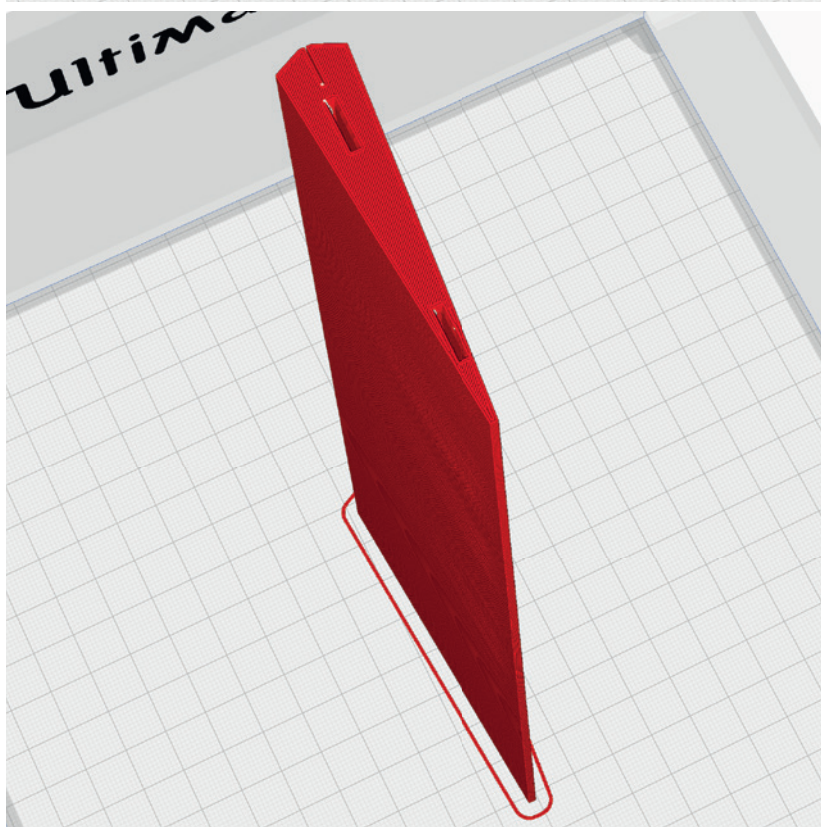



# PROFILE P5\_GYROID Light-Weight LW-PLA!

The following parts must be sliced with the PROFILE P5\_GYROID. Please note the additional settings for the individual parts! It is essential to print these parts with LW-PLA!

**Basic settings for LW-PLA:** Please follow the instructions in our **WINGTEST AND CALIBRATION TOOL** on our website for correct adjustment!

## Aileron 3 left\_p5\_Shard.stl Aileron 3 right\_p5\_Shard.stl

**MATERIAL** LW-PLA, ~ 10 g\*

\*Weighed

### ADDITIONAL SETTINGS

None required

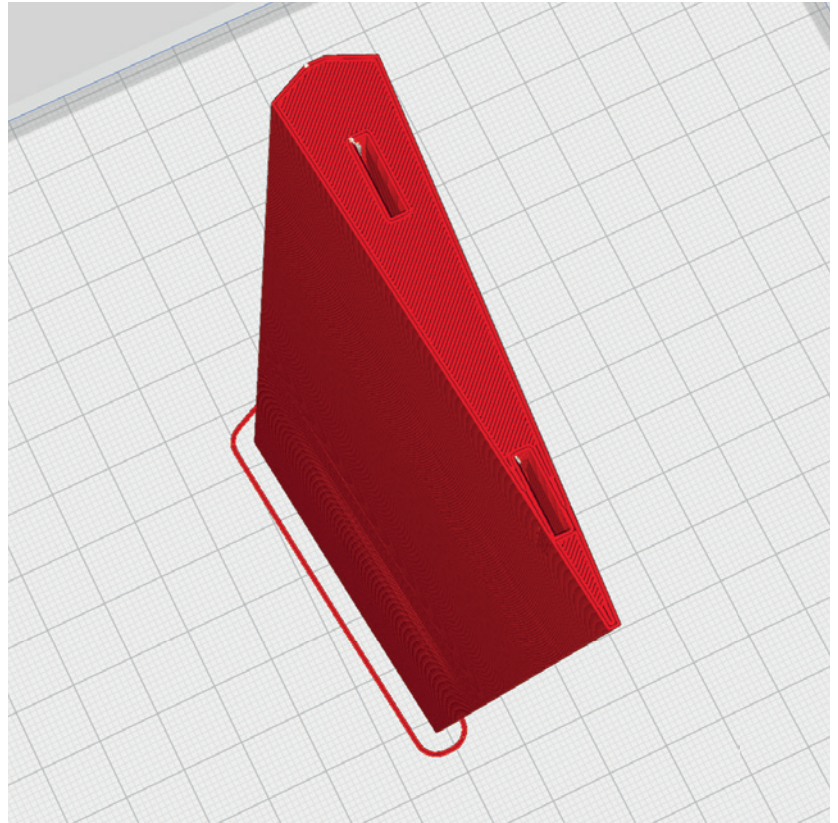

## Canopy 1\_p5\_Shard.stl

**MATERIAL** LW-PLA, ~ 17 g\*

\*Weighed

### ADDITIONAL SETTINGS

None required

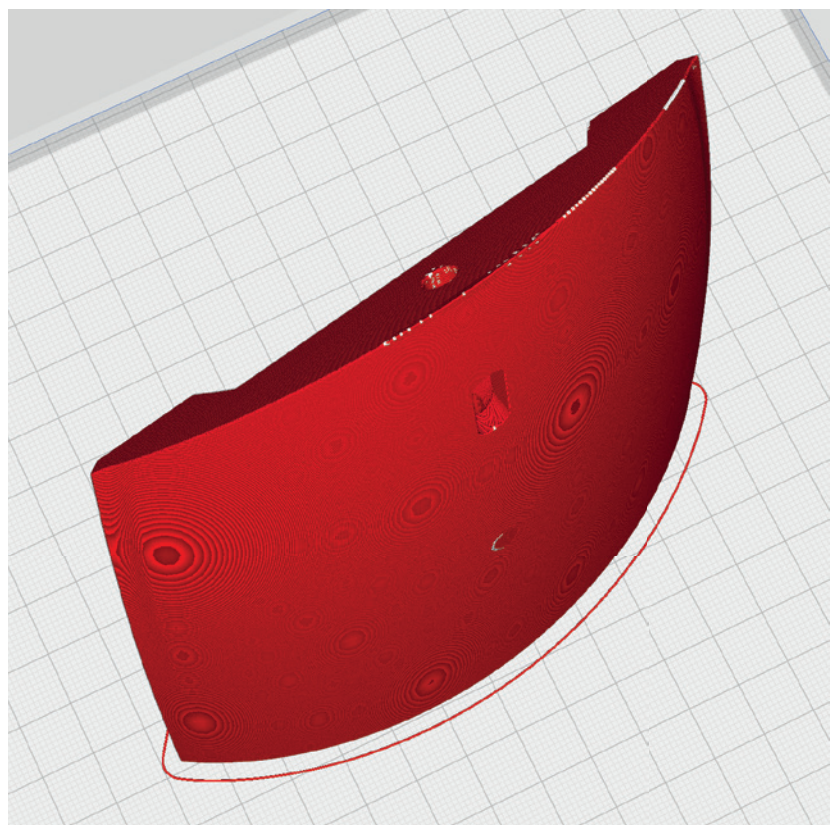



# PROFILE P5\_GYROID Light-Weight LW-PLA!

The following parts must be sliced with the PROFILE P5\_GYROID. Please note the additional settings for the individual parts! It is essential to print these parts with LW-PLA!

**Basic settings for LW-PLA:** Please follow the instructions in our **WINGTEST AND CALIBRATION TOOL** on our website for correct adjustment!

## Canopy 2\_p5\_Shard.stl

**MATERIAL** LW-PLA, ~ 17 g\*

\*Weighed

### ADDITIONAL SETTINGS

None required

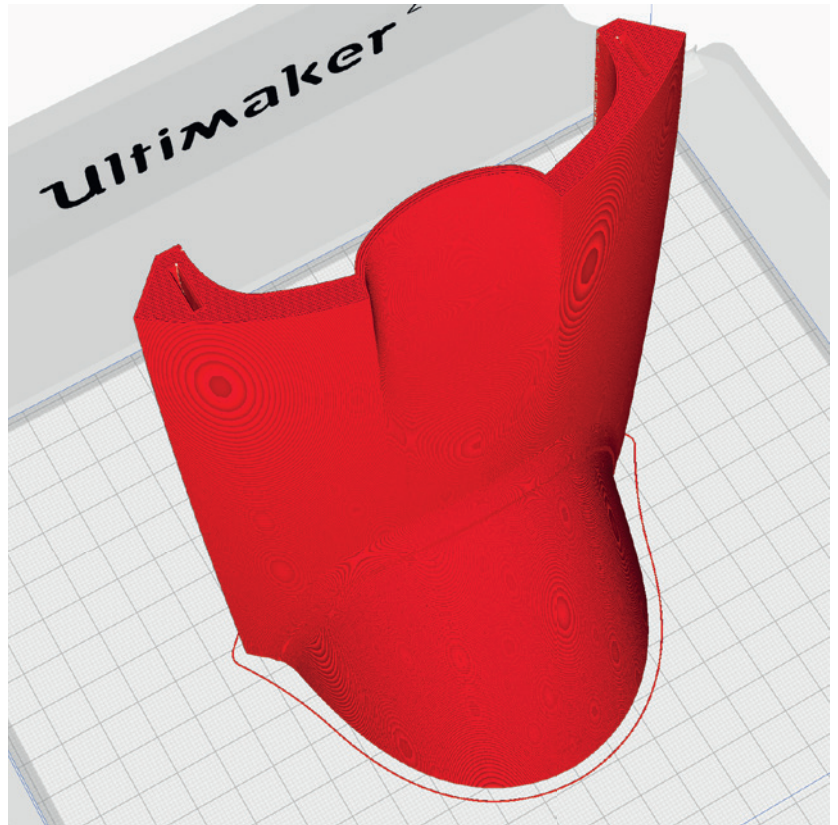

## Canopy 3\_p5\_Shard.stl

**MATERIAL** LW-PLA, ~ 24 g\*

\*Weighed

### ADDITIONAL SETTINGS

None required

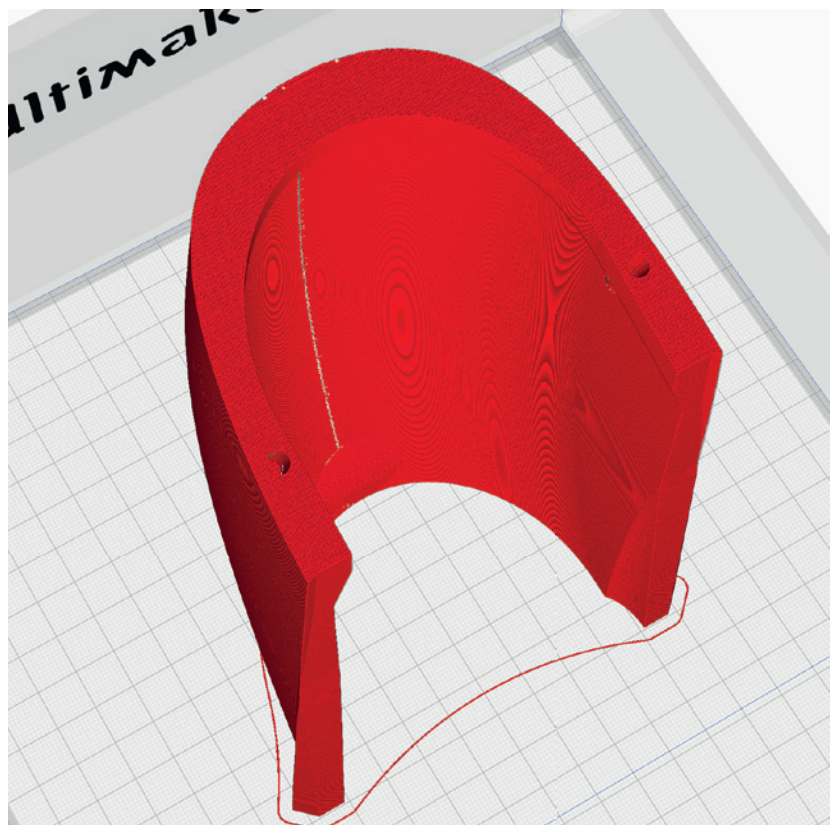

# PROFILE P5\_GYROID Light-Weight LW-PLA!

The following parts must be sliced with the PROFILE P5\_GYROID. Please note the additional settings for the individual parts! It is essential to print these parts with LW-PLA!

**Basic settings for LW-PLA:** Please follow the instructions in our **WINGTEST AND CALIBRATION TOOL** on our website for correct adjustment!

Elevator 1 left\_p5\_Shard.stl  
Elevator 1 right\_p5\_Shard.stl

**MATERIAL** LW-PLA, ~ 9 g\*

\*Weighed

**ADDITIONAL SETTINGS**

None required

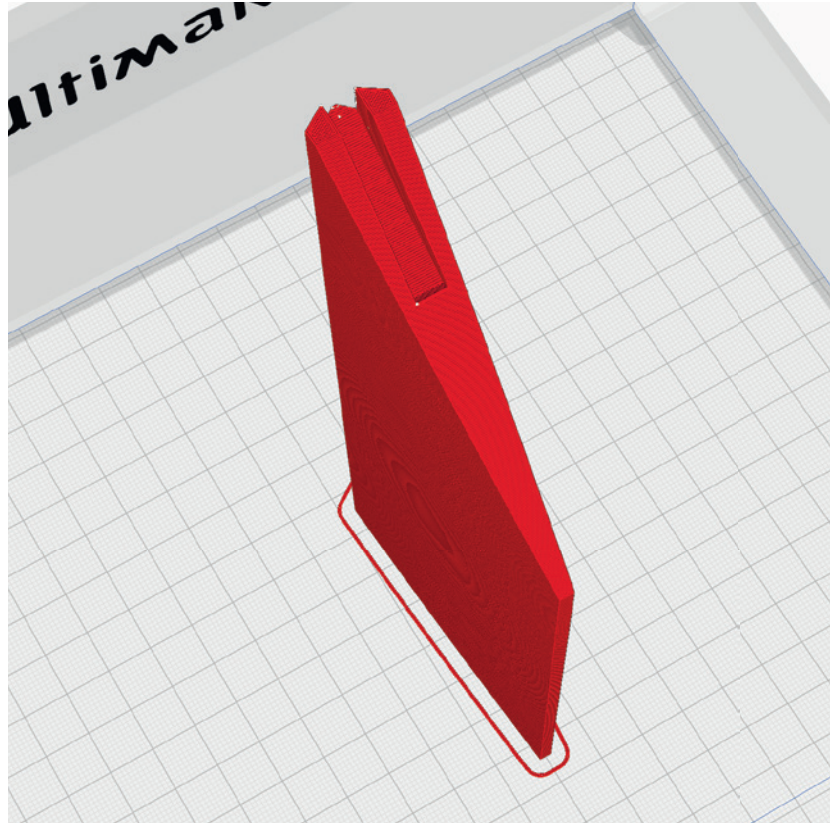

Elevator 2 left\_p5\_Shard.stl  
Elevator 2 right\_p5\_Shard.stl

**MATERIAL** LW-PLA, ~ 8.4 g\*

\*Weighed

**ADDITIONAL SETTINGS**

None required

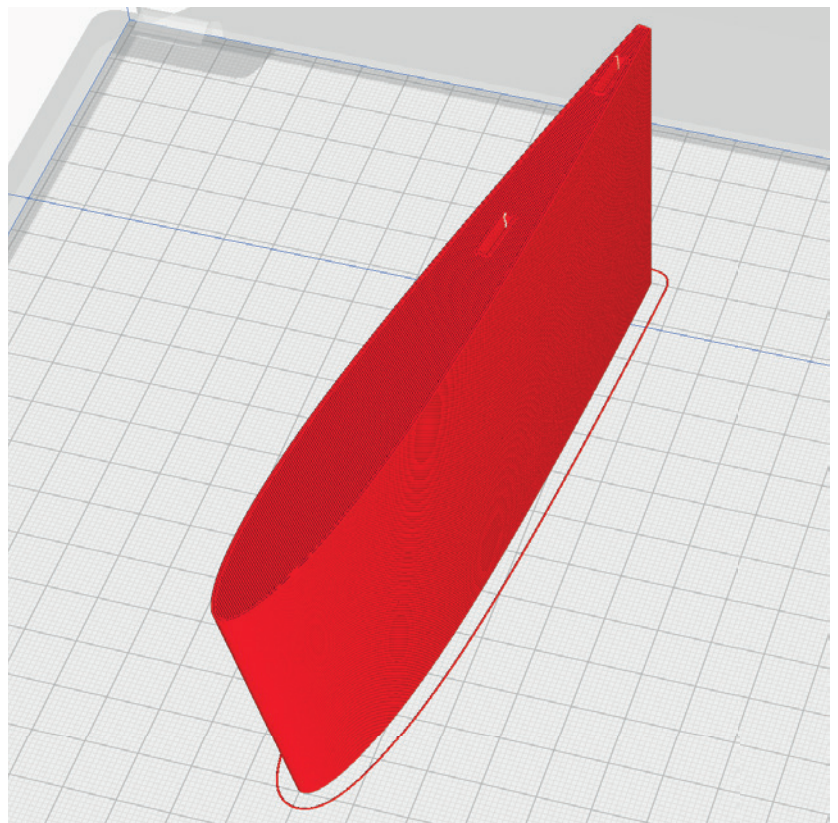



# PROFILE P5\_GYROID Light-Weight LW-PLA!

The following parts must be sliced with the PROFILE P5\_GYROID. Please note the additional settings for the individual parts! It is essential to print these parts with LW-PLA!

**Basic settings for LW-PLA:** Please follow the instructions in our **WINGTEST AND CALIBRATION TOOL** on our website for correct adjustment!

## Fuselage 1\_p5\_Shard.stl

**MATERIAL** LW-PLA, ~ 72 g\*

\*Weighed

### ADDITIONAL SETTINGS

None required

**INFO:** If you have problems with printing, you can also find this part in a split version in the **Optional parts** folder.

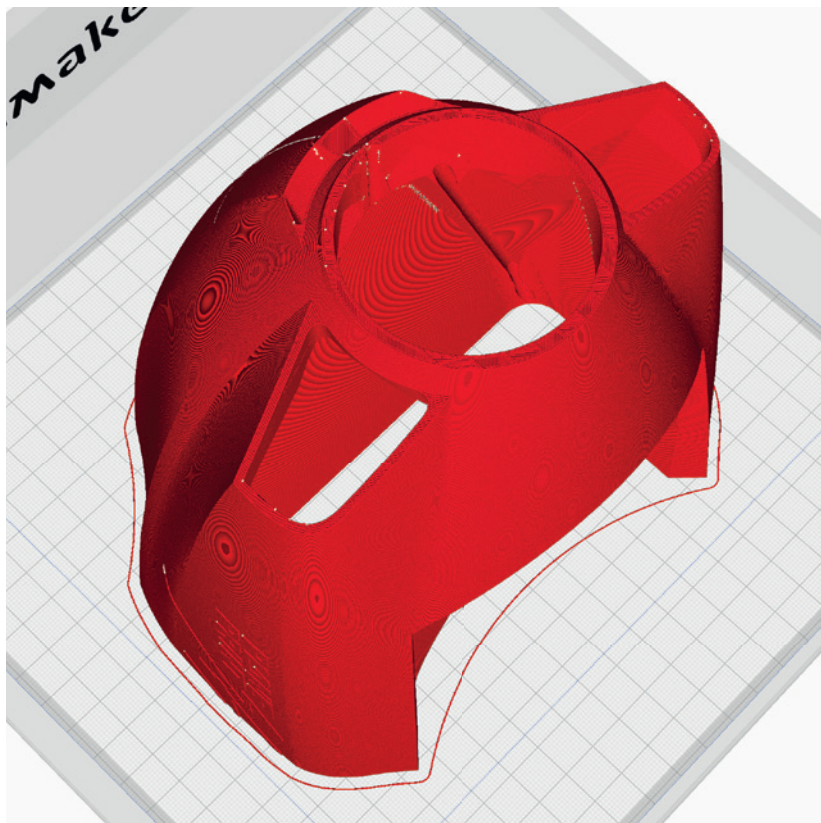

## Fuselage 2 left\_p5\_Shard.stl Fuselage 2 right\_p5\_Shard.stl

**MATERIAL** LW-PLA, ~ 47 g\*

\*Weighed

### ADDITIONAL SETTINGS

None required

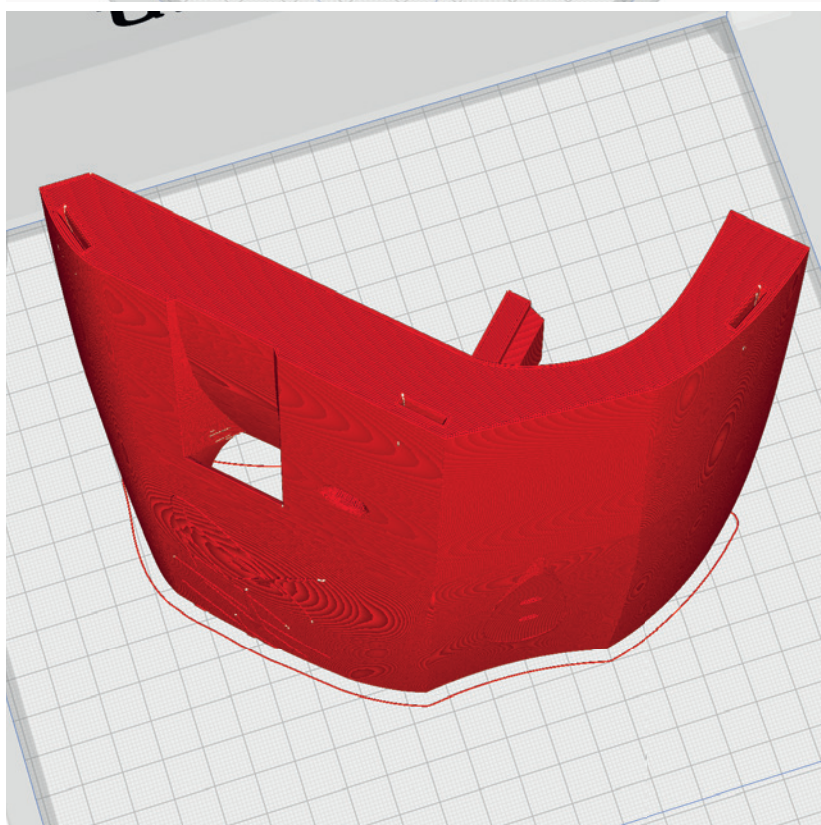

# PROFILE P5\_GYROID Light-Weight LW-PLA!

The following parts must be sliced with the PROFILE P5\_GYROID. Please note the additional settings for the individual parts! It is essential to print these parts with LW-PLA!

**Basic settings for LW-PLA:** Please follow the instructions in our **WINGTEST AND CALIBRATION TOOL** on our website for correct adjustment!

## Fuselage 3\_p5\_Shard.stl

**MATERIAL** LW-PLA, ~ 59 g\*

\*Weighed

### ADDITIONAL SETTINGS

None required

**INFO:** If you have problems with printing, you can also find this part in a split version in the **Optional parts** folder.

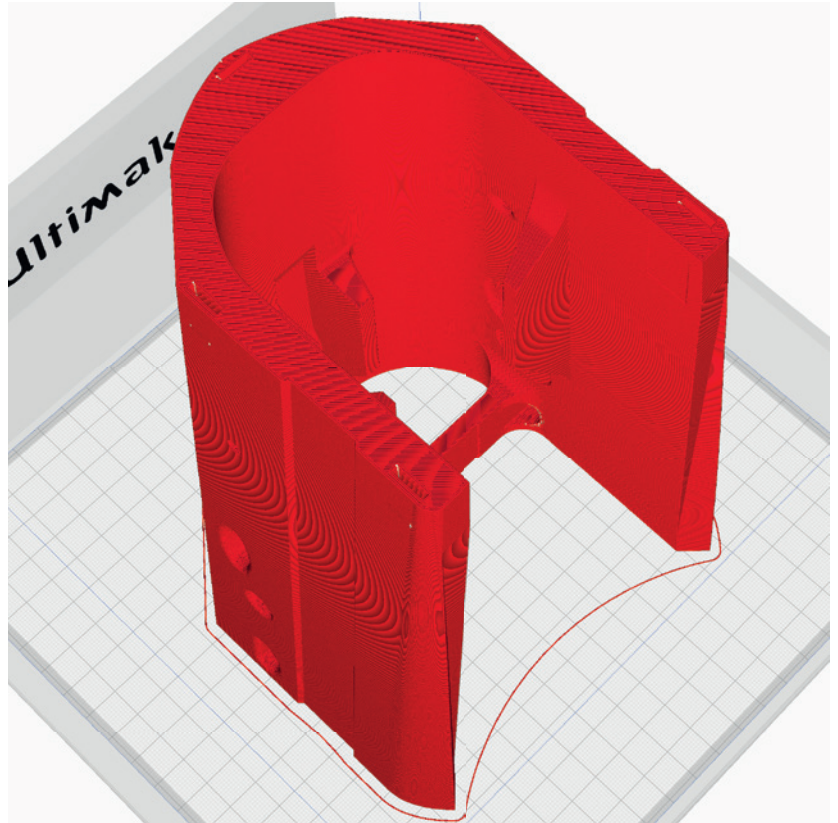

## Fuselage 4\_p5\_Shard.stl

**MATERIAL** LW-PLA, ~ 60 g\*

\*Weighed

### ADDITIONAL SETTINGS

None required

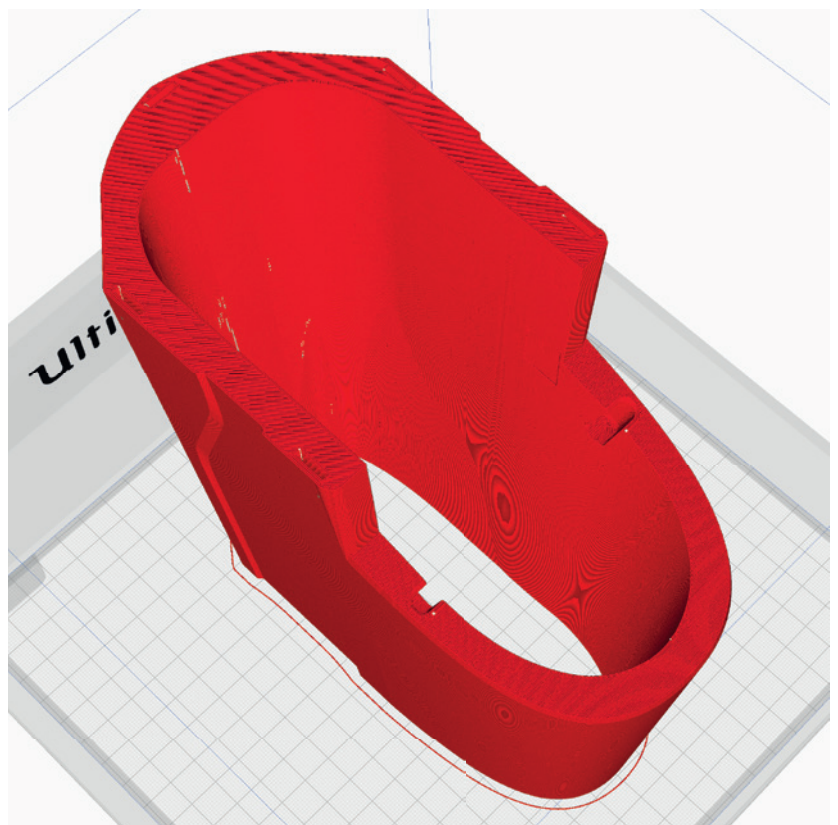



# PROFILE P5\_GYROID Light-Weight LW-PLA!

The following parts must be sliced with the PROFILE P5\_GYROID. Please note the additional settings for the individual parts! It is essential to print these parts with LW-PLA!

**Basic settings for LW-PLA:** Please follow the instructions in our **WINGTEST AND CALIBRATION TOOL** on our website for correct adjustment!

## Fuselage 5\_p5\_Shard.stl

**MATERIAL** LW-PLA, ~ 46 g\*

\*Weighed

### ADDITIONAL SETTINGS

None required

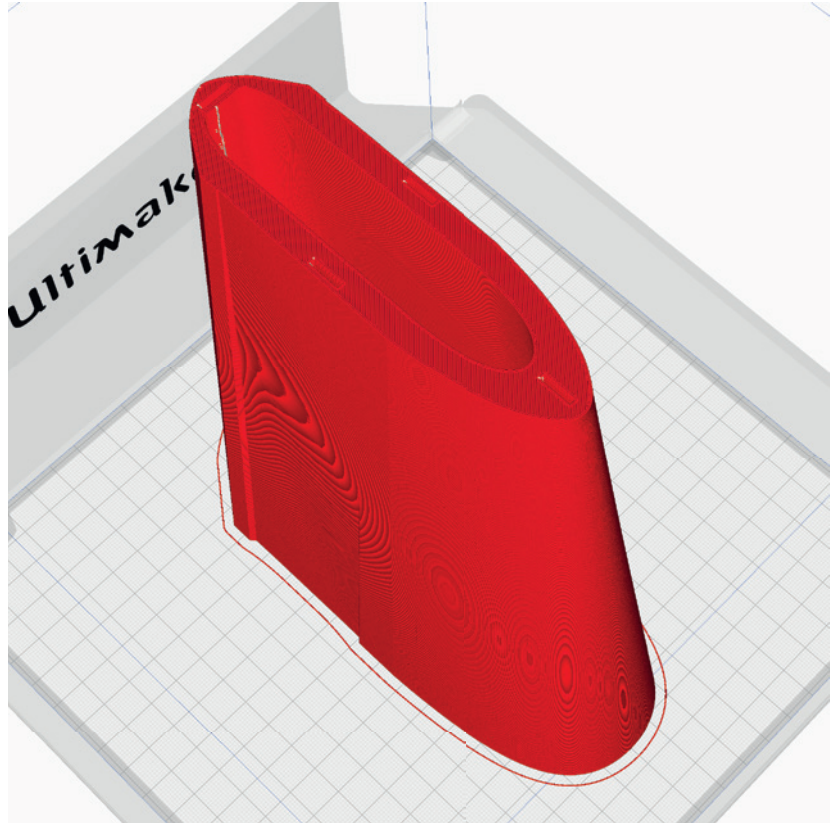

## Fuselage 6\_p5\_Shard.stl

**MATERIAL** LW-PLA, ~ 12 g\*

\*Weighed

### ADDITIONAL SETTINGS

None required

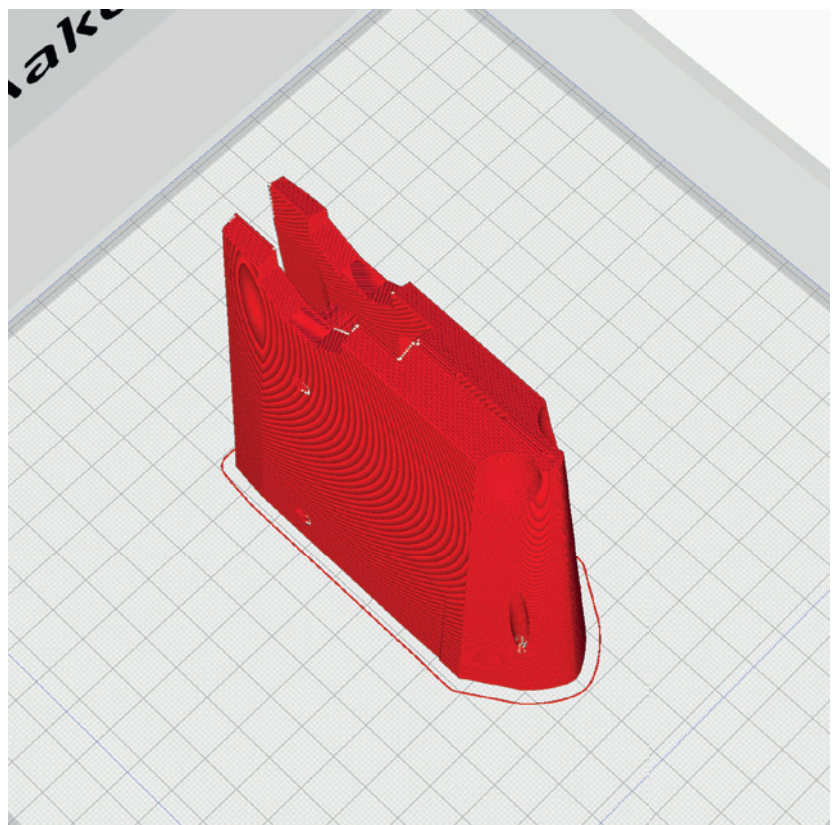

# PROFILE P5\_GYROID Light-Weight LW-PLA!

The following parts must be sliced with the PROFILE P5\_GYROID. Please note the additional settings for the individual parts! It is essential to print these parts with LW-PLA!

**Basic settings for LW-PLA:** Please follow the instructions in our **WINGTEST AND CALIBRATION TOOL** on our website for correct adjustment!

## Gear Leg R+L\_p5\_Shard.stl

**MATERIAL** LW-PLA, ~ 5.8 g\*

\*Weighed

### ADDITIONAL SETTINGS

- Print this part twice



## HS left\_p5\_Shard.stl HS right\_p5\_Shard.stl

**MATERIAL** LW-PLA, ~ 18 g\*

\*Weighed

### ADDITIONAL SETTINGS

None required

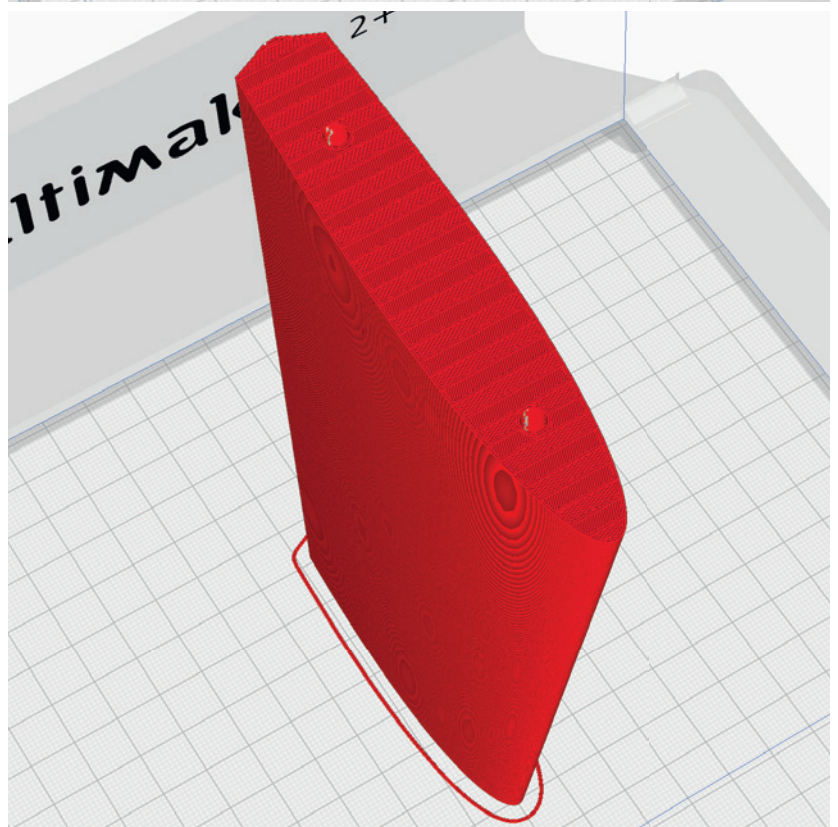



# PROFILE P5\_GYROID Light-Weight LW-PLA!

The following parts must be sliced with the PROFILE P5\_GYROID. Please note the additional settings for the individual parts! It is essential to print these parts with LW-PLA!

**Basic settings for LW-PLA:** Please follow the instructions in our **WINGTEST AND CALIBRATION TOOL** on our website for correct adjustment!

## Rudder 1\_p5\_Shard.stl

**MATERIAL** LW-PLA, ~ 14 g\*

\*Weighed

### ADDITIONAL SETTINGS

None required

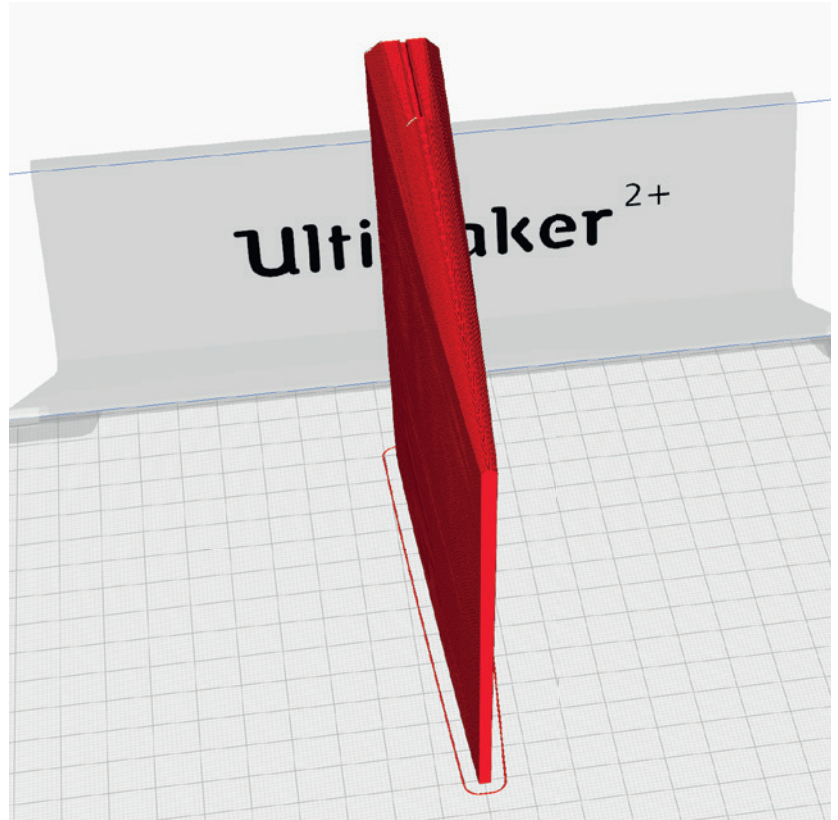

## Rudder 2\_p5\_Shard.stl

**MATERIAL** LW-PLA, ~ 15 g\*

\*Weighed

### ADDITIONAL SETTINGS

None required

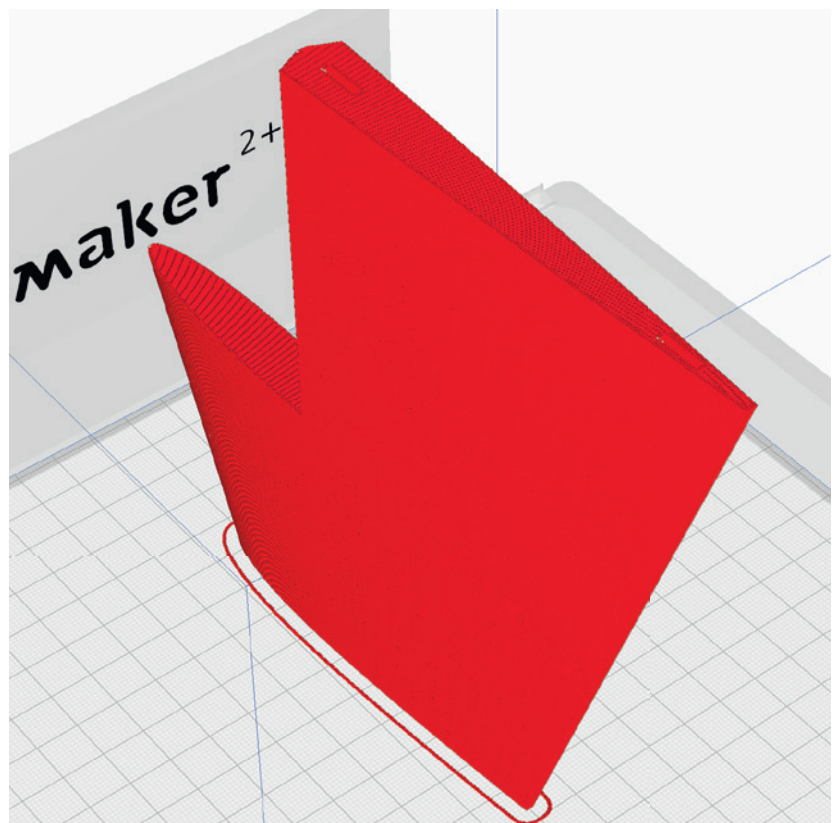

# PROFILE P5\_GYROID Light-Weight LW-PLA!

The following parts must be sliced with the PROFILE P5\_GYROID. Please note the additional settings for the individual parts! It is essential to print these parts with LW-PLA!

**Basic settings for LW-PLA:** Please follow the instructions in our **WINGTEST AND CALIBRATION TOOL** on our website for correct adjustment!

## SFG 1 R+L\_p5\_Shard.stl

**MATERIAL** LW-PLA, ~ 3 g\*

\*Weighed

### ADDITIONAL SETTINGS

- Print this part twice

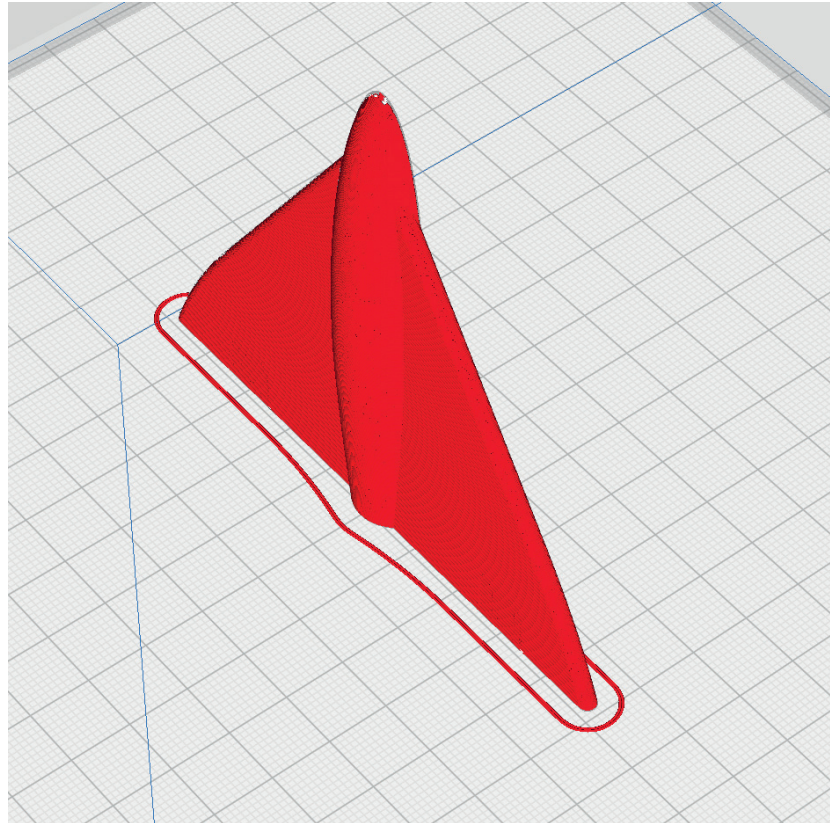

## SFG 2 R+L\_p5\_Shard.stl

**MATERIAL** LW-PLA, ~ 3.5 g\*

\*Weighed

### ADDITIONAL SETTINGS

- Print this part twice

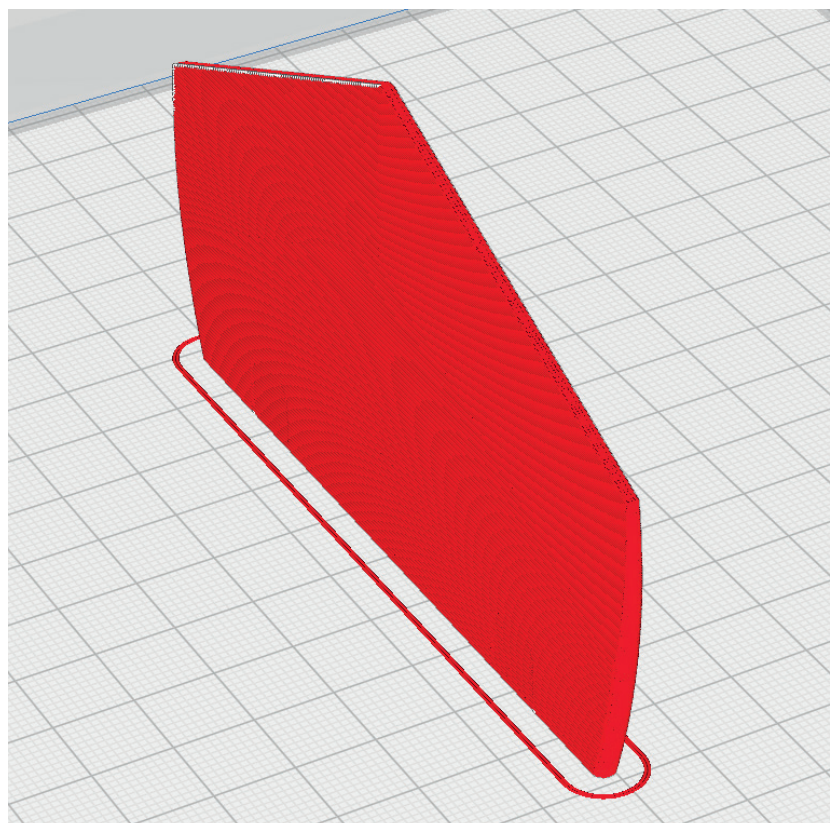



# PROFILE P5\_GYROID Light-Weight LW-PLA!

The following parts must be sliced with the PROFILE P5\_GYROID. Please note the additional settings for the individual parts! It is essential to print these parts with LW-PLA!

**Basic settings for LW-PLA:** Please follow the instructions in our **WINGTEST AND CALIBRATION TOOL** on our website for correct adjustment!

## Spinner\_p5\_Shard.stl

**MATERIAL** LW-PLA, ~ 7 g\*

\*Weighed

### ADDITIONAL SETTINGS

- We recommend to print the spinner with a little more material flow (80%)

**INFO:** On [www.planenprint.com/shard](http://www.planenprint.com/shard) under **Free tuning parts** you will find a version for larger props.

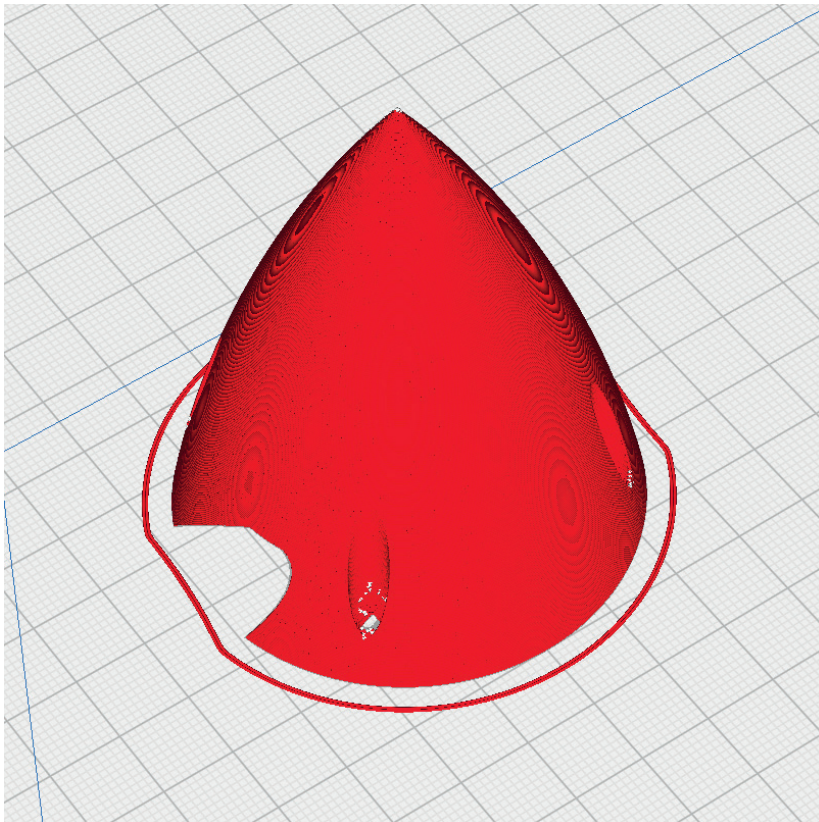

## VS\_p5\_Shard.stl

**MATERIAL** LW-PLA, ~ 14 g\*

\*Weighed

### ADDITIONAL SETTINGS

None required

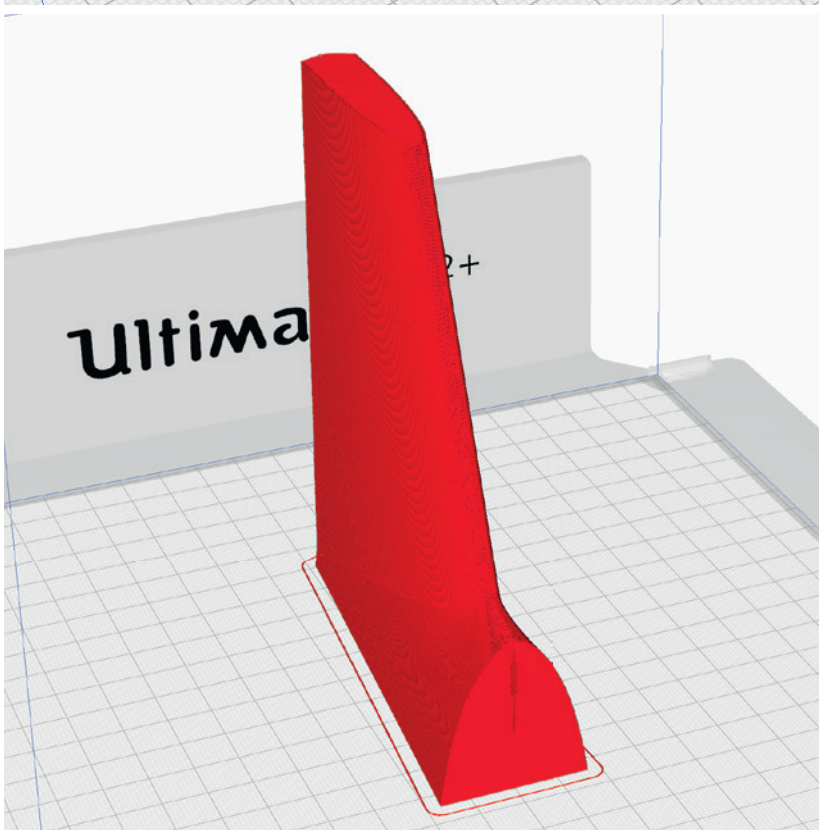

# PROFILE P5\_GYROID Light-Weight LW-PLA!

The following parts must be sliced with the PROFILE P5\_GYROID. Please note the additional settings for the individual parts! It is essential to print these parts with LW-PLA!

**Basic settings for LW-PLA:** Please follow the instructions in our **WINGTEST AND CALIBRATION TOOL** on our website for correct adjustment!

Wheel Cap 1 left\_p5\_Shard.stl  
Wheel Cap 1 right\_p5\_Shard.stl

**MATERIAL** LW-PLA, ~ 5 g\*

\*Weighed

**ADDITIONAL SETTINGS**

None required

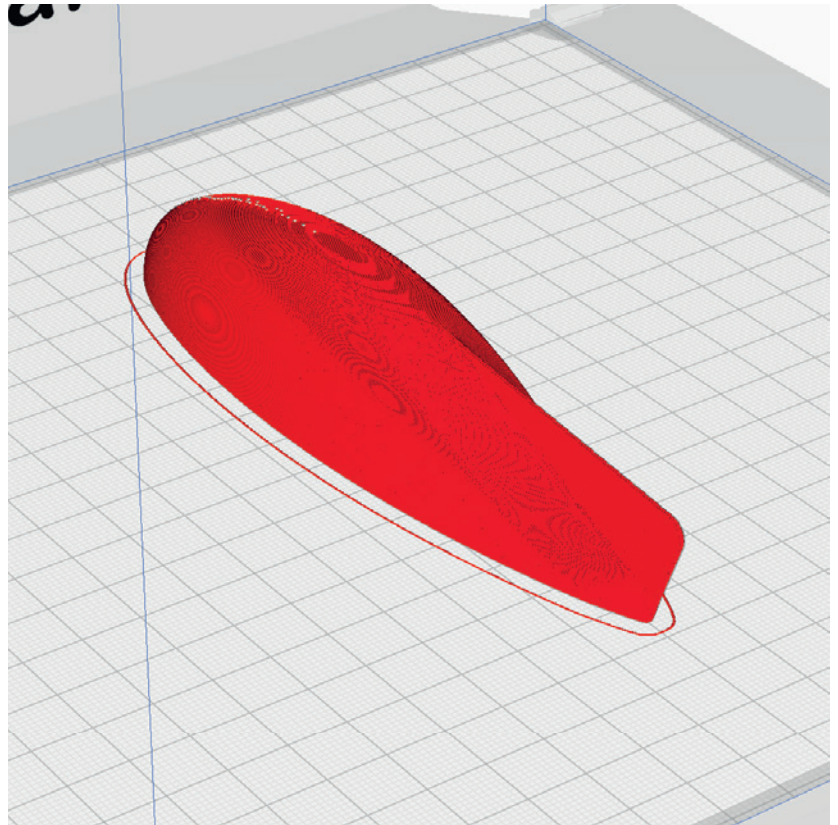

Wheel Cap 2 left\_p5\_Shard.stl  
Wheel Cap 2 right\_p5\_Shard.stl

**MATERIAL** LW-PLA, ~ 3.1 g\*

\*Weighed

**ADDITIONAL SETTINGS**

None required

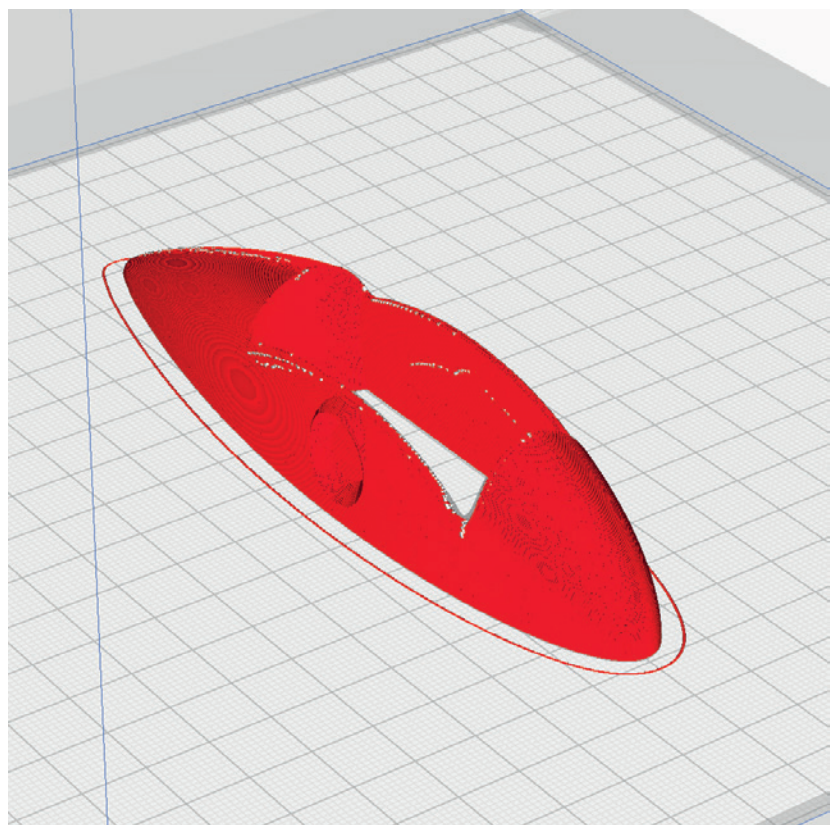



# PROFILE P5\_GYROID Light-Weight LW-PLA!

The following parts must be sliced with the PROFILE P5\_GYROID. Please note the additional settings for the individual parts! It is essential to print these parts with LW-PLA!

**Basic settings for LW-PLA:** Please follow the instructions in our **WINGTEST AND CALIBRATION TOOL** on our website for correct adjustment!

Wing 1 left\_p5\_Shard.stl  
Wing 1 right\_p5\_Shard.stl

**MATERIAL** LW-PLA, ~ 65 g\*

\*Weighed

## ADDITIONAL SETTINGS

- left: Z Seam Position: back right
- right: Z Seam Position: back left

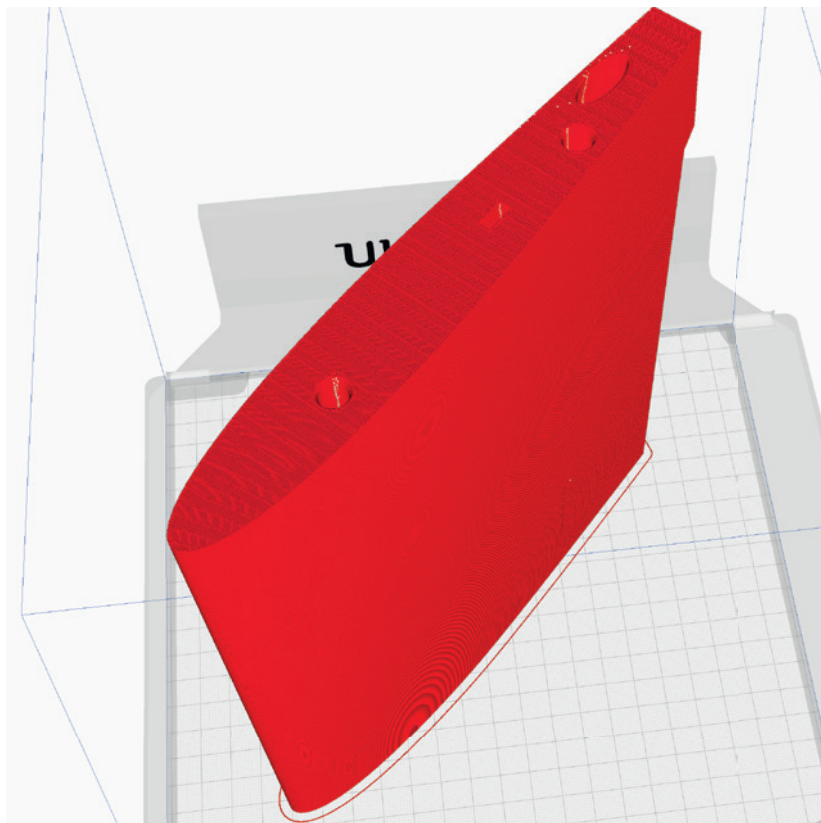

Wing 1 part left\_p5\_Shard.stl  
Wing 1 part right\_p5\_Shard.stl

**MATERIAL** LW-PLA, ~ 3.6 g\*

\*Weighed

## ADDITIONAL SETTINGS

None required

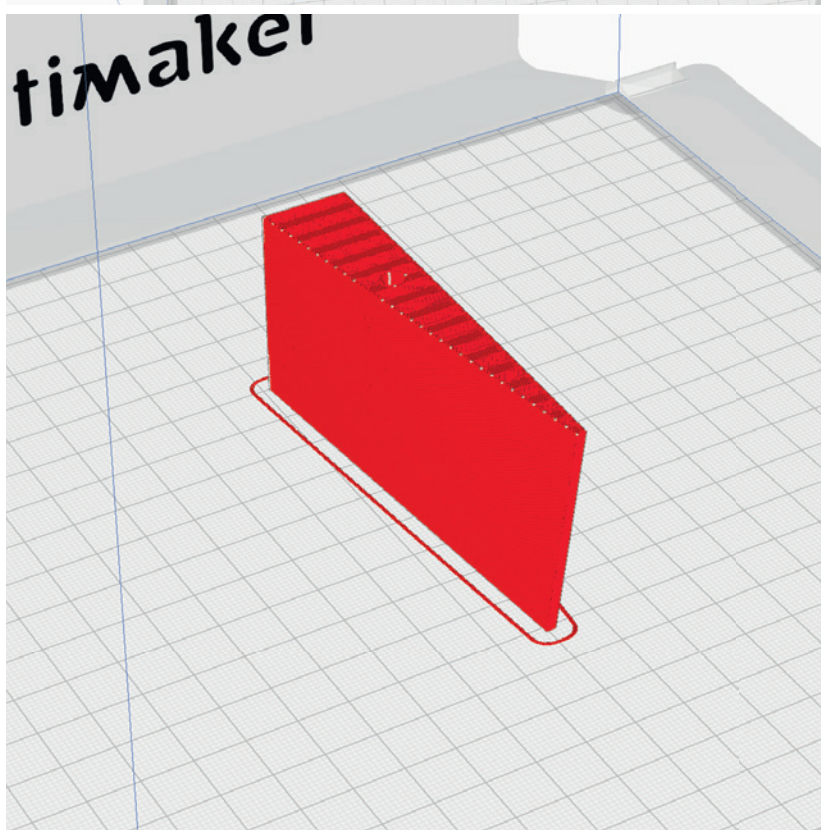

# PROFILE P5\_GYROID Light-Weight LW-PLA!

The following parts must be sliced with the PROFILE P5\_GYROID. Please note the additional settings for the individual parts! It is essential to print these parts with LW-PLA!

**Basic settings for LW-PLA:** Please follow the instructions in our **WINGTEST AND CALIBRATION TOOL** on our website for correct adjustment!

Wing 2 left\_p5\_Shard.stl  
Wing 2 right\_p5\_Shard.stl

**MATERIAL** LW-PLA, ~ 50 g\*

\*Weighed

**ADDITIONAL SETTINGS**

None required

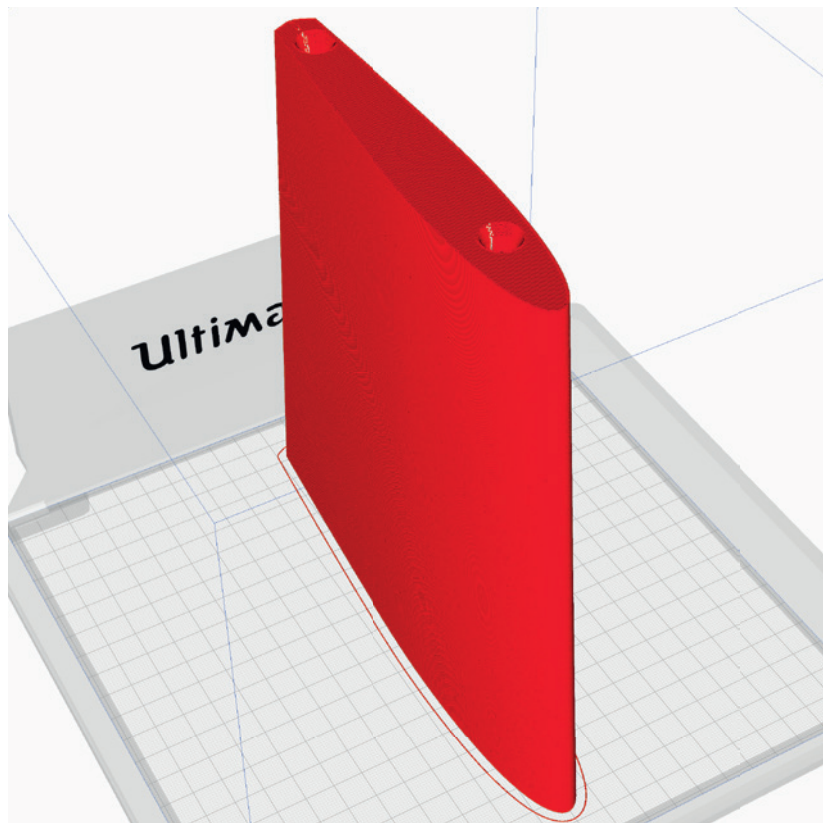

Wing 3 left\_p5\_Shard.stl  
Wing 3 right\_p5\_Shard.stl

**MATERIAL** LW-PLA, ~ 36 g\*

\*Weighed

**ADDITIONAL SETTINGS**

None required

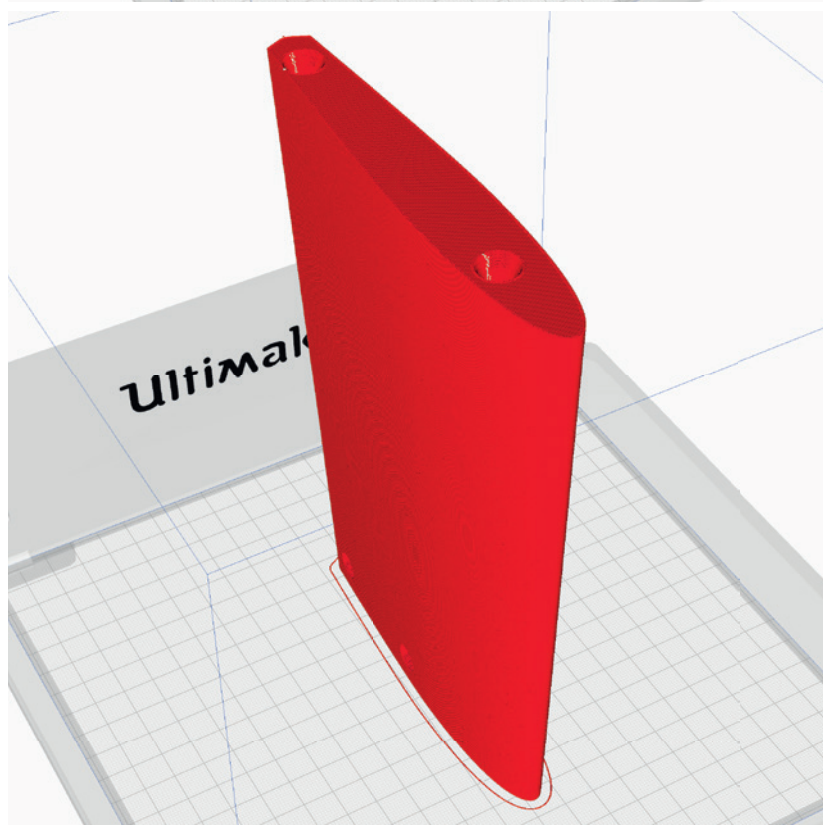



# PROFILE P5\_GYROID Light-Weight LW-PLA!

The following parts must be sliced with the PROFILE P5\_GYROID. **Please note the additional settings for the individual parts! It is essential to print these parts with LW-PLA!**

**Basic settings for LW-PLA:** Please follow the instructions in our **WINGTEST AND CALIBRATION TOOL** on our website for correct adjustment!

## X\_p5\_Shard.stl

**MATERIAL** LW-PLA, ~ 1.7 g\*

\*Weighed

### **ADDITIONAL SETTINGS**

None required

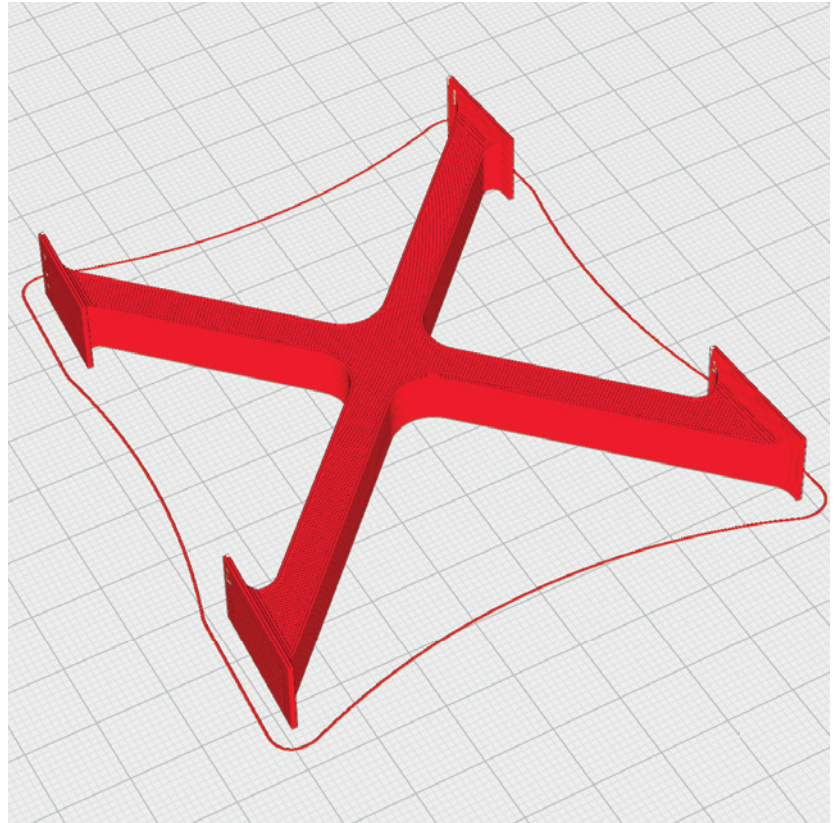

# Required accessoires

## Filament

- normal PLA( or Tough PLA) about 135 grams
- LW-PLA 1000 grams (**recommended**)
- TPU (A95) about 10 grams
- LW-TPU Colorfabb VarioShore about 10 grams  
(**strongly recommended for tires, but it also works with normal TPU**)

**PRINTING TIME** About 119 hours/5 days

## Materials

- some tapping screws  
(**simply search for: M2 flat head tapping screw assortment**) →
- Grub screw Ø3mm, 4 pieces
- Metal screw 3\*20mm with self-locking nut, 4 pieces
- Metal screw 3\*37mm with 2 nuts, 2 pieces
- CA super glue (liquid and liquid medium)
- CA activator
- Carbon tube Ø8mm\*1000mm (inside 6mm), 2 pieces
- Carbon rod Ø4\*1000mm, 3 pieces\*
- Steel wire Ø1mm\*200mm
- Self-adhesive Velcro tape
- Velcro strap (2 pieces)
- Servo cable extension 100mm, 2 pieces
- Rod connection, 4 pieces
- Neodym-Super-Magnet 5x5x5mm, 4 pieces
- Pull/Pull Steel Wire Control Set 0.8mm, 2 pieces
- Metal rod clamp, 4 pieces
- some Hair gums
- some Cable ties

## Tools

- Cutter knife
- small Philips screwdriver
- Drill Ø1.5mm, Ø2.5mm, Ø4mm
- needle-nose pliers

**\*Cut the 4mm rods into the following parts:**

**Rod 1:** 3x 265, 1x 200

**Rod 2:** 1x 265, 2x 180, 1x 150, 1x 100, 2x 40, 1x 30

**Rod 3:** 1x 170, 3x 150, 1x 75, 1x 30



Rod connection

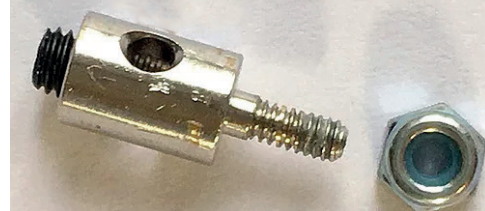

Metal screw 3\*37mm



Pull/Pull Steel Wire Control Set



Metal rod clamp

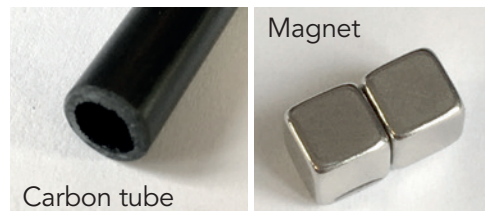

Carbon tube

Magnet



# RC Components

**ENGINE** PROPDRIVE V2 3548 900KV (HobbyKing) or comparable motors.  
**You can also use any other motor that fits a 14x7 propeller!**

Pay attention to the position of the motor shaft

**NOTE** This motorization is very powerful and optimized for 3d maneuvers. The Shard is not full throttle safe with it. Always be careful, it is up to your discretion and the quality of your printing and assembly as to what stresses the aircraft can withstand.

**PROP** 14x6 or 14x7, we recommend wooden propellers

**BEC-CONTROLLER** 80 A (must fit the engine!)

**RECEIVER** 5 Channel

**BATTERY** 4S Lipo, 3200 – 3500 MaH  
(The battery should have a weight of 340 to 390 grams)

**SERVOS** **4 pieces** like **Corona 939MG, Corona 929MG** or comparable  
**The servos should necessarily have metal gears and a torque of at least 2 to 4 Kg/cm!**  
**The speed should be at least 0.15 sec/60° or faster.**

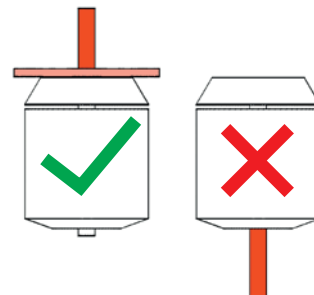

Dimensions:

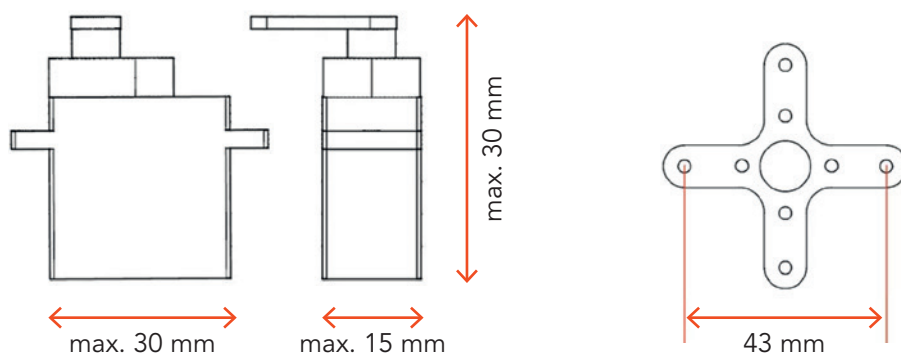

# PLANE PRINT SHARD

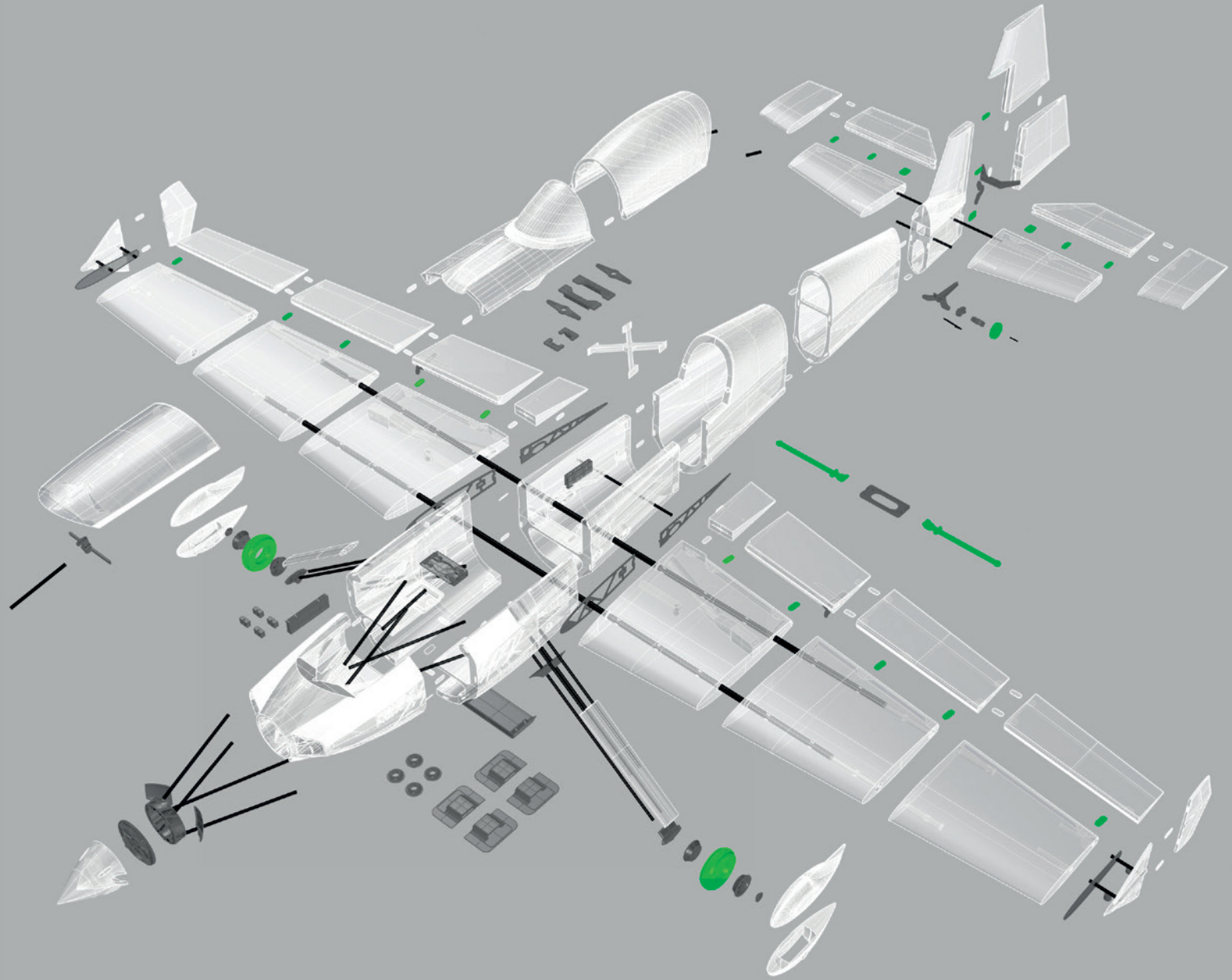

LW-PLA



PLA+



TPU



CARBON



## Basic Information:

# Gluing together the parts printed with PROFILE P5

- STEP 1** As a first step, it is important to **roughen and smooth the adhesive surfaces** with sandpaper.
- STEP 2** Insert the **interconnects into the slots** provided on one side.
- STEP 3** Apply a **lot of glue** to the side with the interconnects. It is important that there is glue everywhere, especially on the outside and inside of the wall surfaces, in order to achieve a perfect connection. The interconnects only serve to align the parts to each other. It is better **not** to apply glue here, otherwise it can happen that the glue suddenly hardens while the parts are being put together and stops the process.

Use **medium viscosity CA glue**, thinner glue would run down the parts too easily.

After assembly, **align the two parts exactly** and wipe off the excess CA glue from the surface with a cloth. Now spray with activator spray along the gluing surface and carefully press the parts together.

- STEP 4** Clean the glued areas slightly with a **sharp-bladed** cutter.



## Installing the hinges – rudder/elevator/ailerons

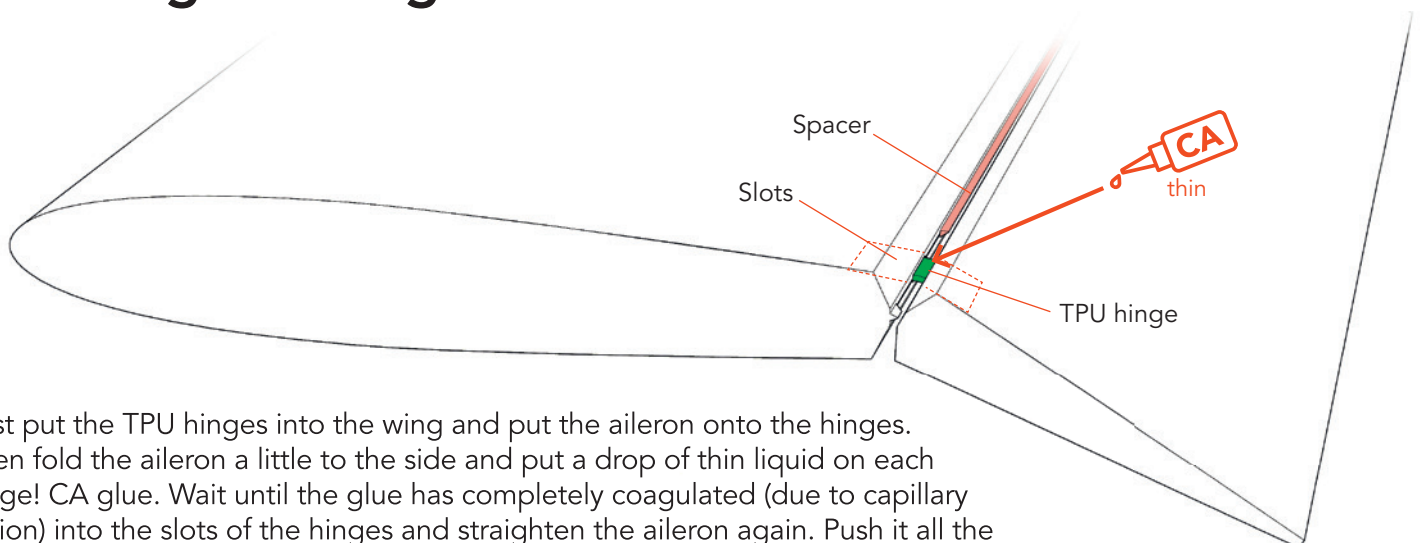

First put the TPU hinges into the wing and put the aileron onto the hinges. Then fold the aileron a little to the side and put a drop of thin liquid on each hinge! CA glue. Wait until the glue has completely coagulated (due to capillary action) into the slots of the hinges and straighten the aileron again. Push it all the way to the wing, printed spacers provide the correct distance. Now spray some activator spray on each hinge to cure the CA glue. Repeat on the other side of the hinges. **Do not use too much glue and test if each hinge holds well.**

# Wing assembly



The carbon rods must be glued in at right angles to the side force generator.

Wing protectors\_p1\_Shard.stl

Wing 3 left\_p5\_Shard.stl

Wing 2 left\_p5\_Shard.stl

Wing 1 left\_p5\_Shard.stl

Interconnects\_p1\_Shard.stl

Wing 1 part left\_p5\_Shard.stl

SFG 1 R+L\_p5\_Shard.stl

SFG 2 R+L\_p5\_Shard.stl

Carbon rods  
Ø4mm\*40mm

Use the carbon tubes to align the parts exactly, but **make sure that no glue gets on the tubes!**

Wing protectors\_p1\_Shard.stl

Carbon tubes  
Ø8mm\*1000mm



# Wing assembly

Glue the three sleeves into the wing so that they are flush on the surface.

Attach the Side Force Generator to the wing and tighten the screws just enough to hold it in place.

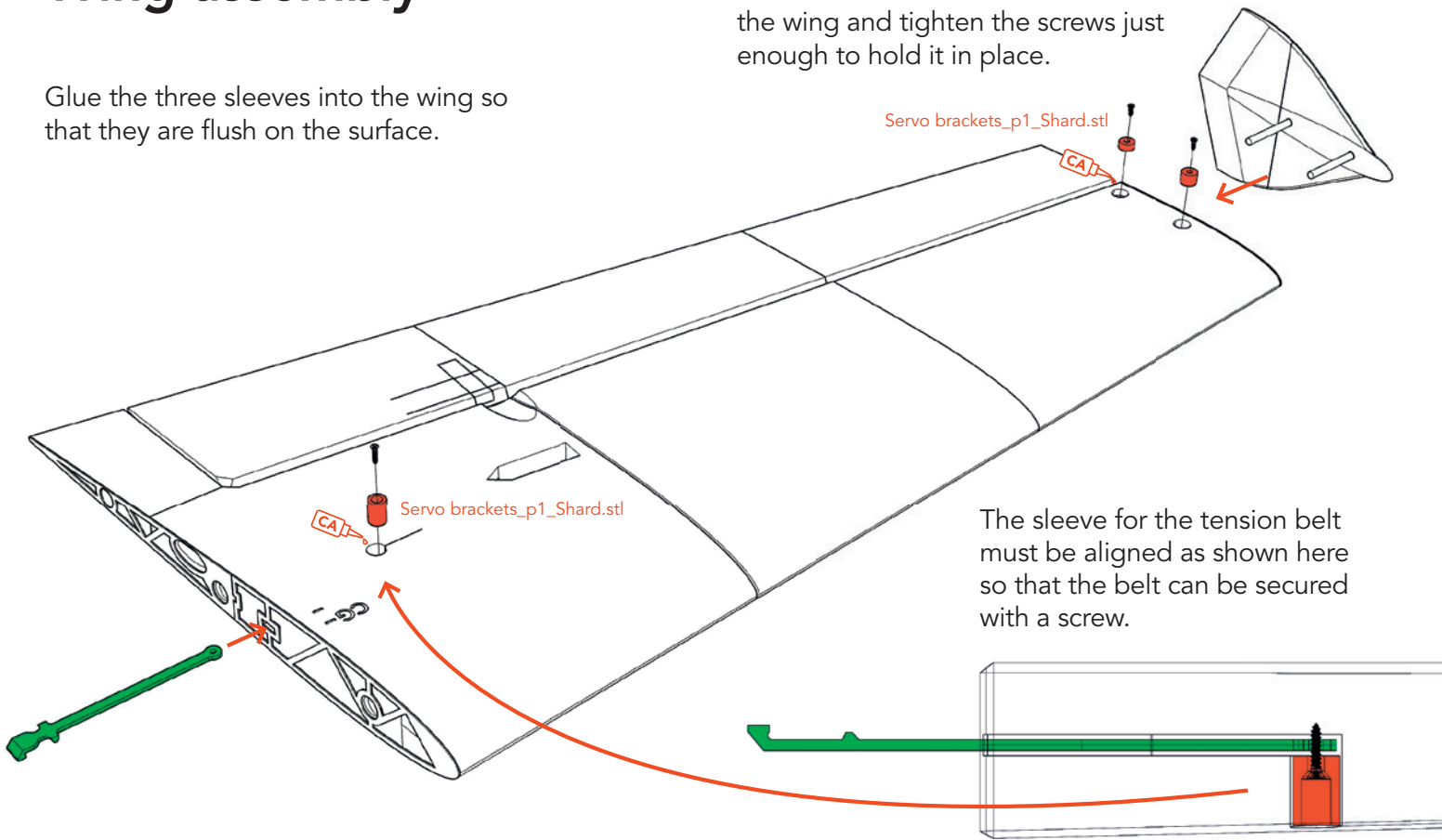

The sleeve for the tension belt must be aligned as shown here so that the belt can be secured with a screw.

# Servo aileron

Mount the servos as shown in the picture.

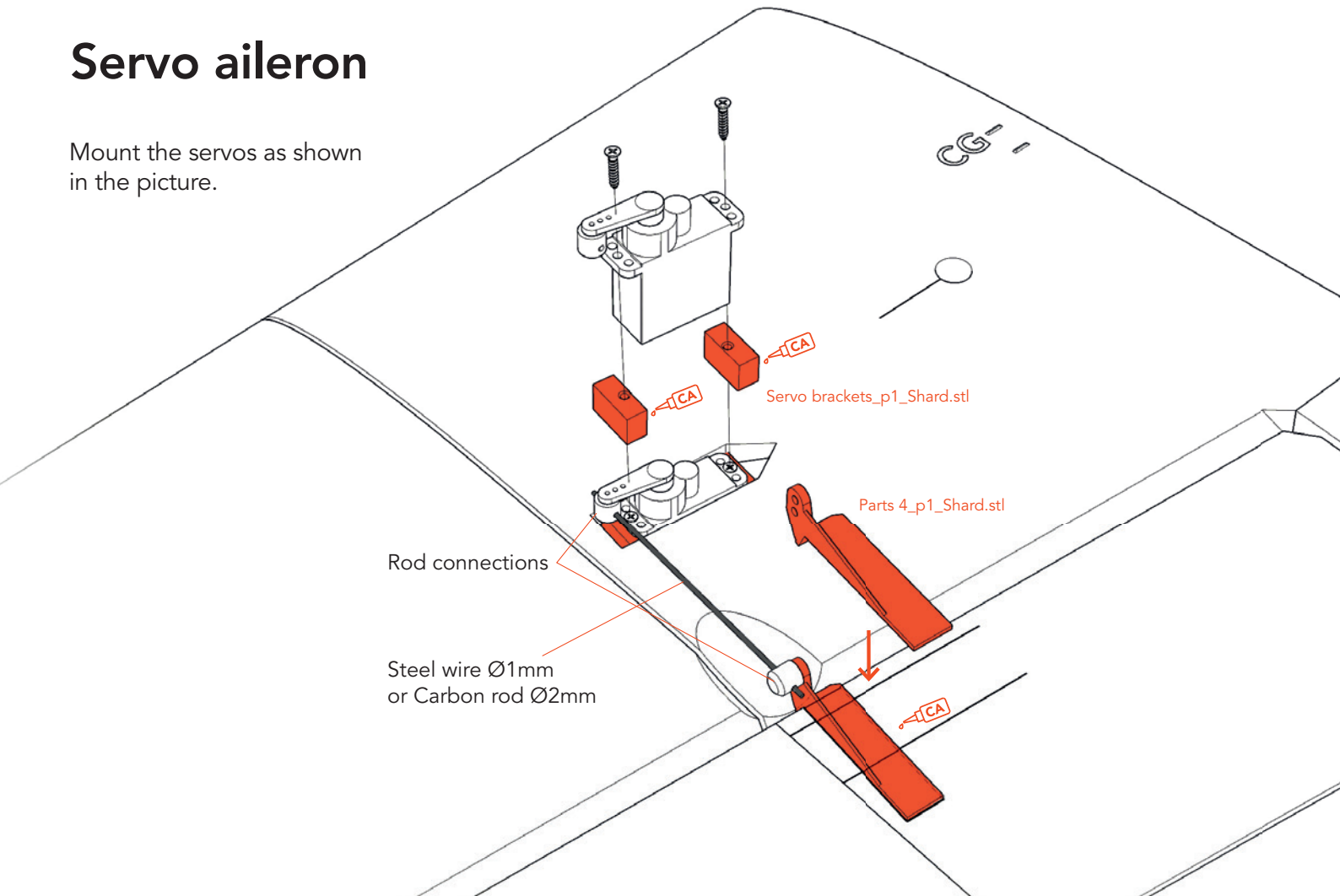

# Fuselage assembly



Start with the part Fuselage 2

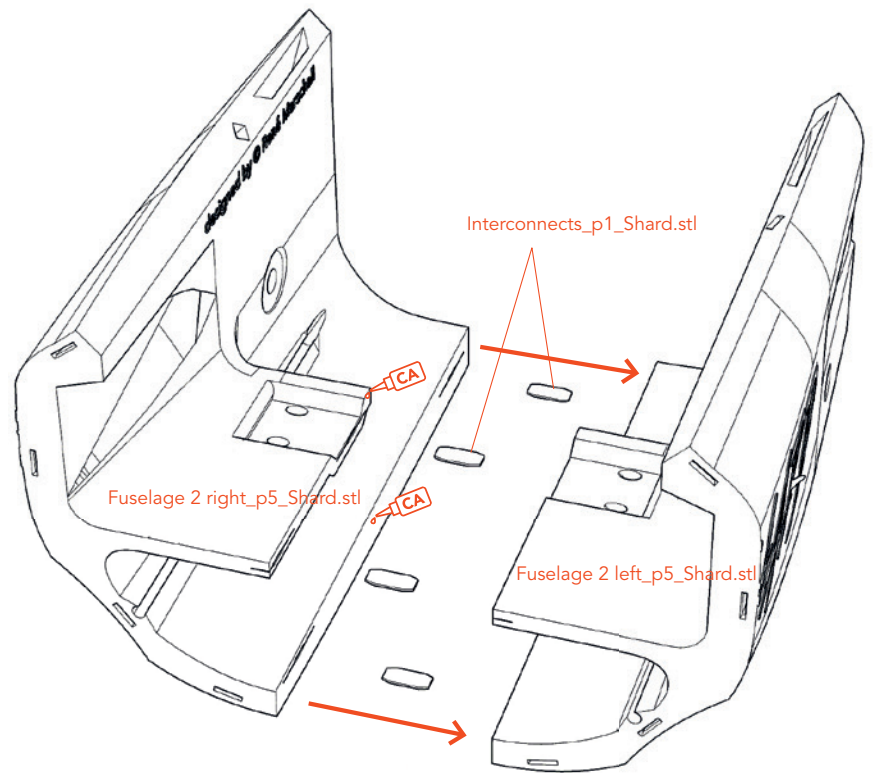

**IMPORTANT** Before the fuselage can be mounted, the reinforcement for the main landing gear must be glued in place!

Put the parts together with the carbon rods as shown in the picture and fix the short carbon tubes and the PLA part in the fuselage at a few points with **medium CA glue** (only so little that you can remove the four long carbon rods). Now apply **thin CA glue** along the short carbon rods and the PLA part in the fuselage.

**Make sure that these parts are glued to the fuselage over a large area, this is very important for the stability of the main landing gear.**

Put the carbon rods back into the fuselage and glue the PLA parts to the outside of the fuselage.

**Make sure that no glue gets on the carbon rods, these must be removed again!**

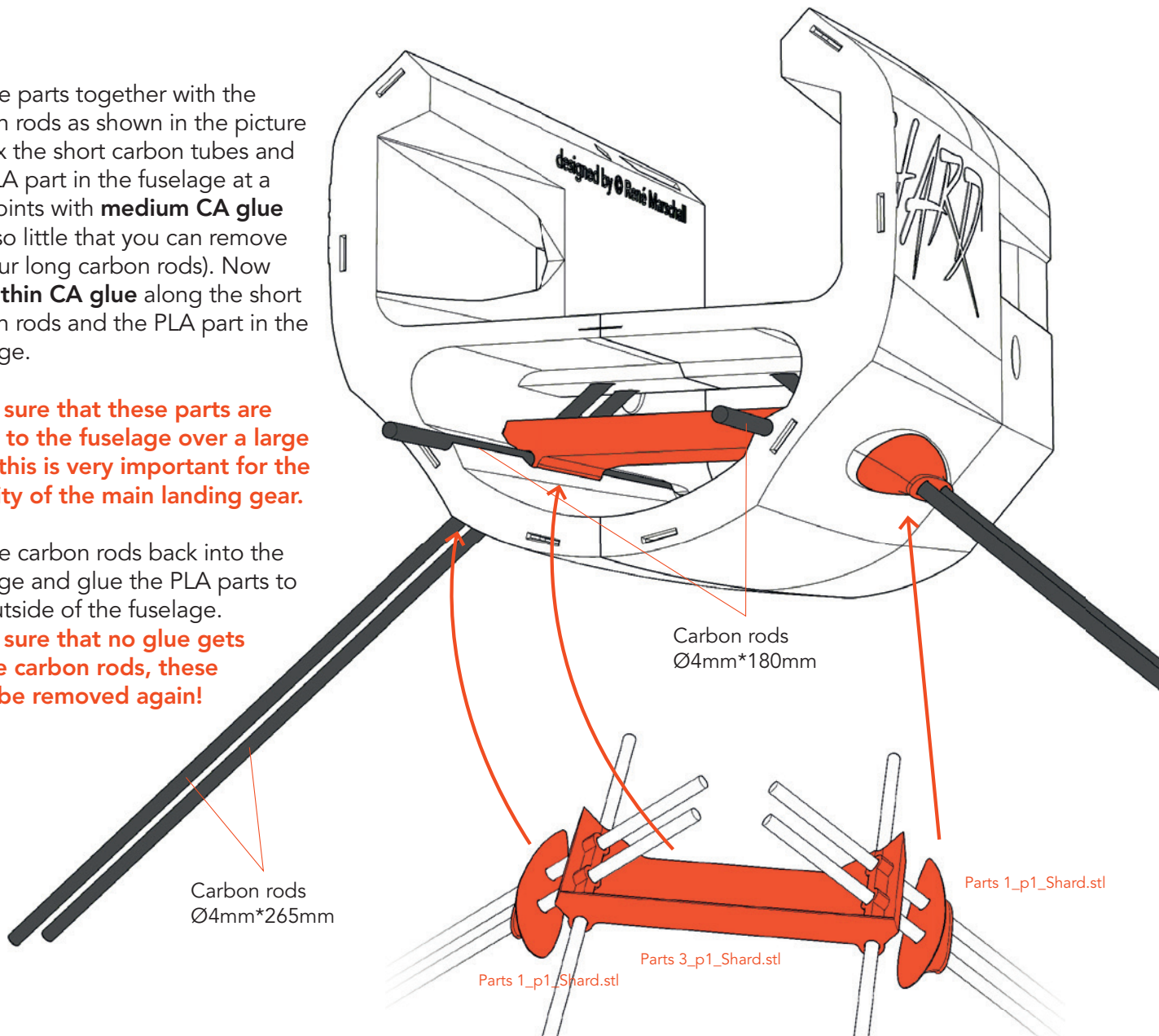



# Fuselage assembly



Assemble the parts as shown in the picture. The motor mount must be exactly flush with the fuselage at the front. Then run **thin CA glue** over the entire surface of the motor mount and the carbon rods.

**This glue connection is very important so that the motor is well fixed!**

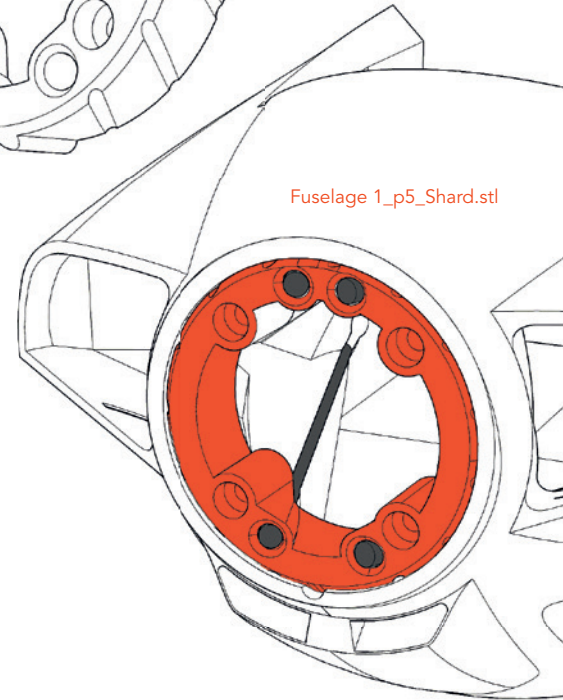
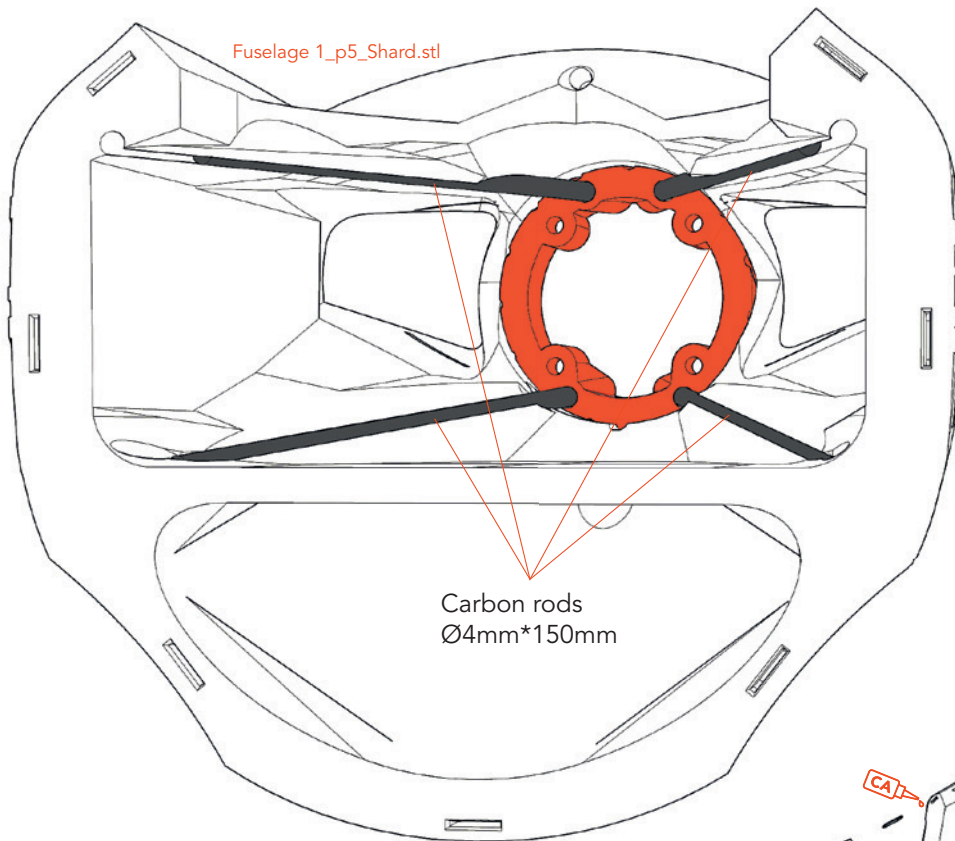
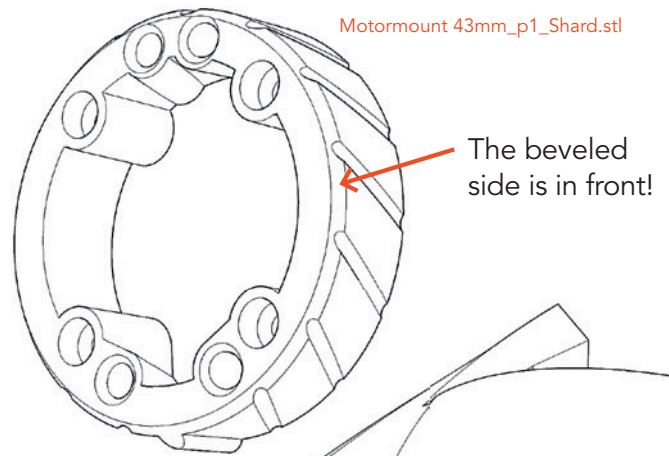

Now the parts fuselage 1 to fuselage 5 can be mounted.

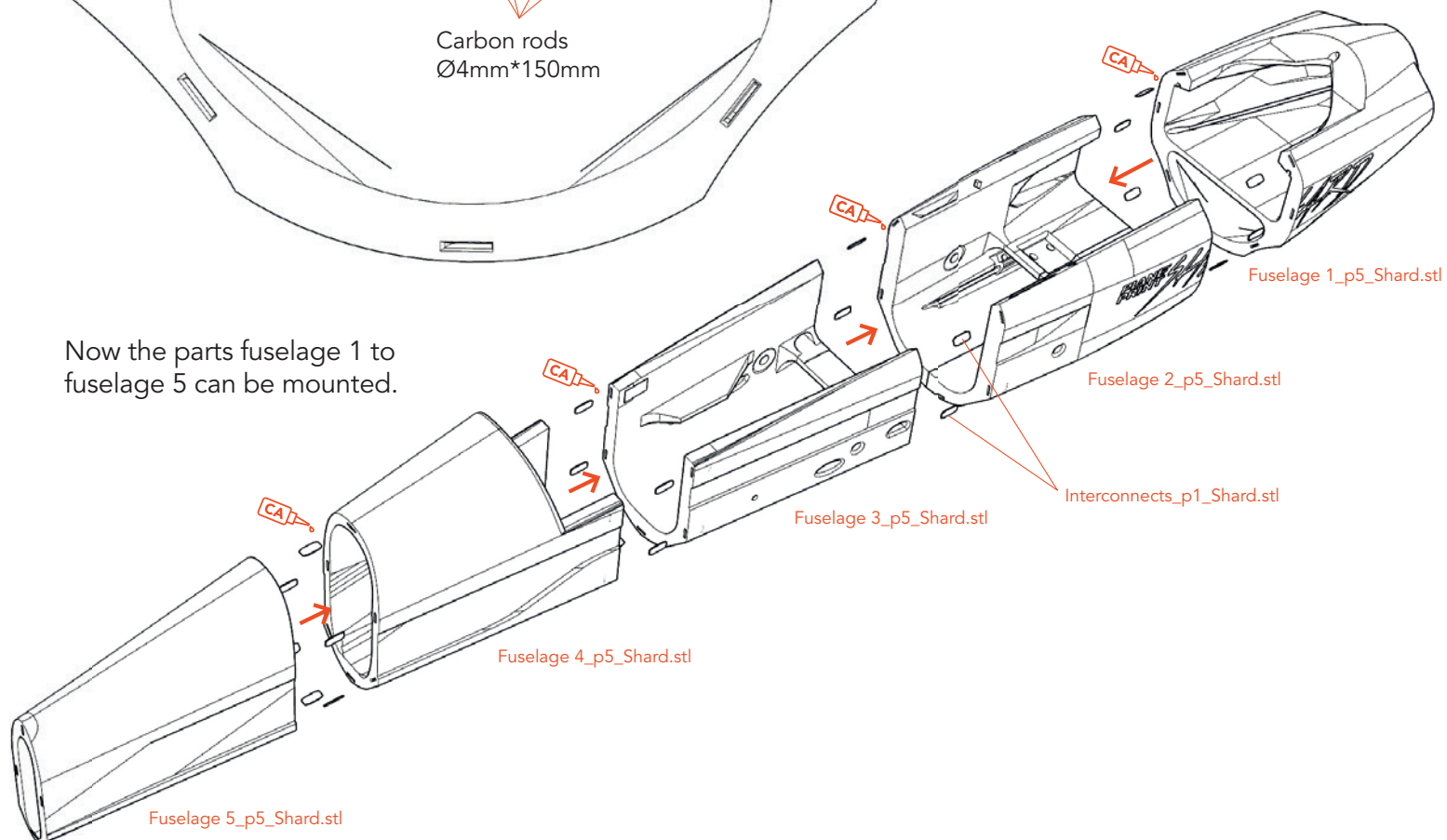

# Elevator assembly

When gluing the connecting part, make sure that the elevators are aligned exactly parallel! Stick the control horn on at the end and push it all the way to the front.

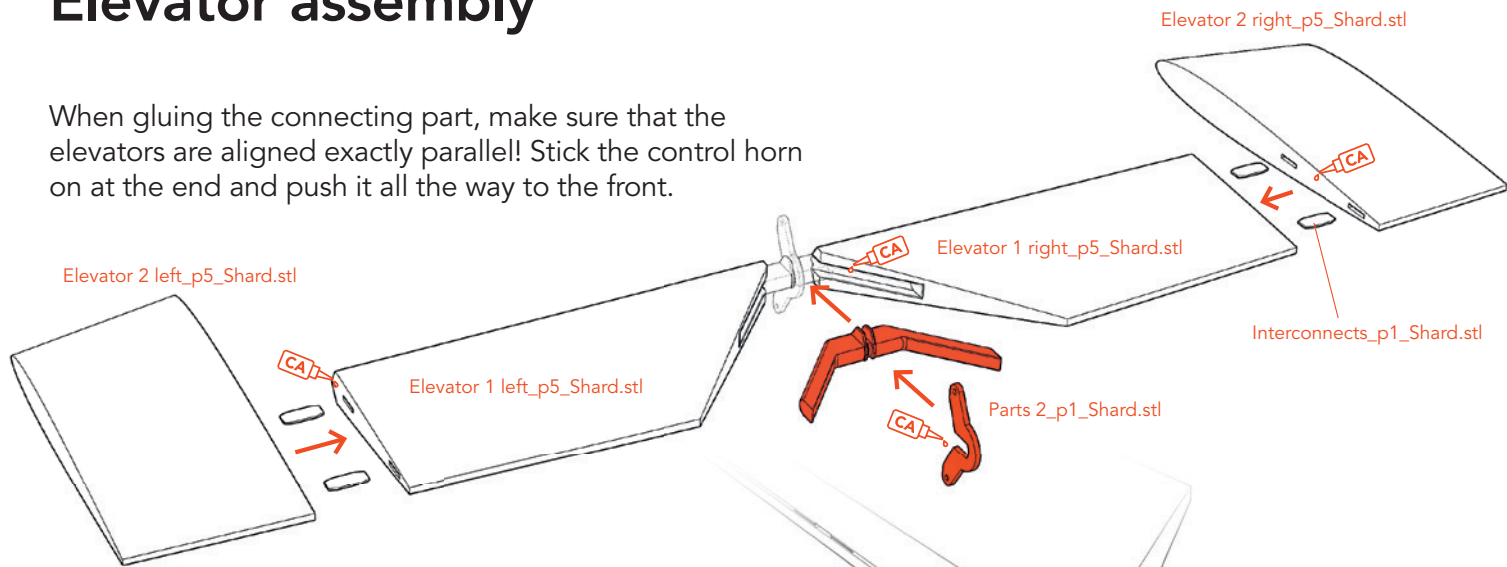

**IMPORTANT** Before the elevator is mounted, the steel wire control must be attached as shown in the picture. Use pliers to press the aluminum sleeves tight.

# Tailplane assembly

Glue all parts, including the carbon rods.

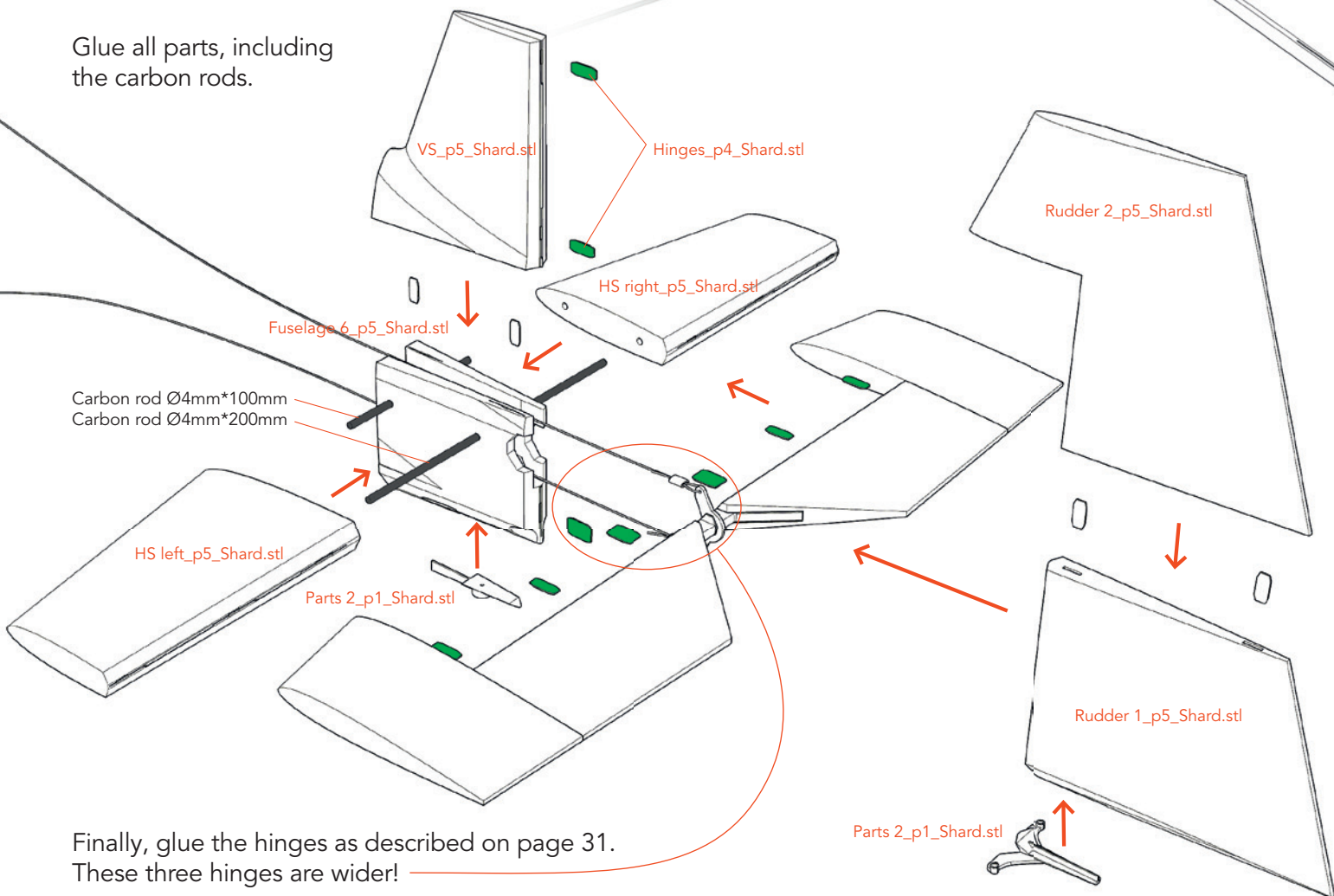

Finally, glue the hinges as described on page 31. These three hinges are wider!



# Pull-pull Rudder and Elevator linkage

Insert the rope guides into the holes of fuselage 6 and glue them in place.

Install the steel wire control as shown in the picture. Use pliers to press the aluminum sleeves tight.

Parts\_2\_p1\_Shard.stl

Make sure that there is still free thread left for retensioning!

Mount the control horn for the servos and glue the servo brackets in the fuselage as shown in the picture.

The ropes for the rudder should be crossed.

Make sure that the ropes are taut and hang the rod clamps in the second hole from the inside.

Servo brackets\_p1\_Shard.stl

Servo brackets\_p1\_Shard.stl

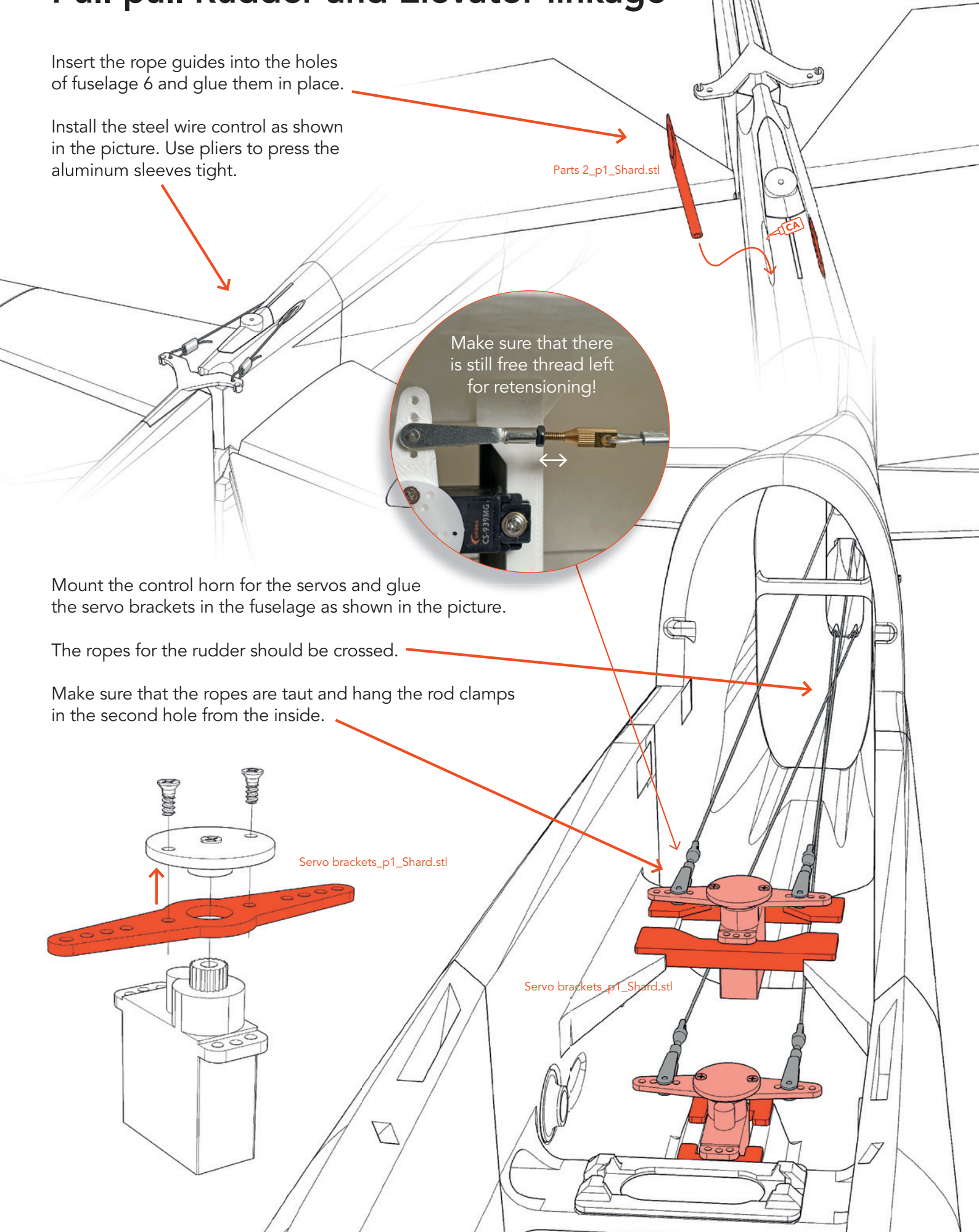
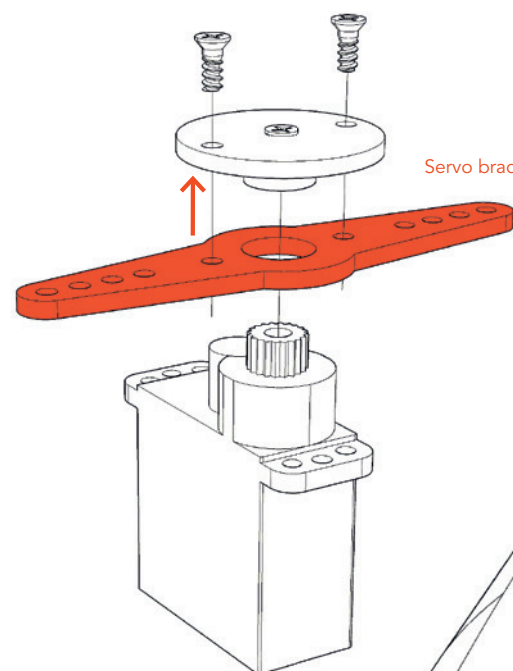

# Gear assembly

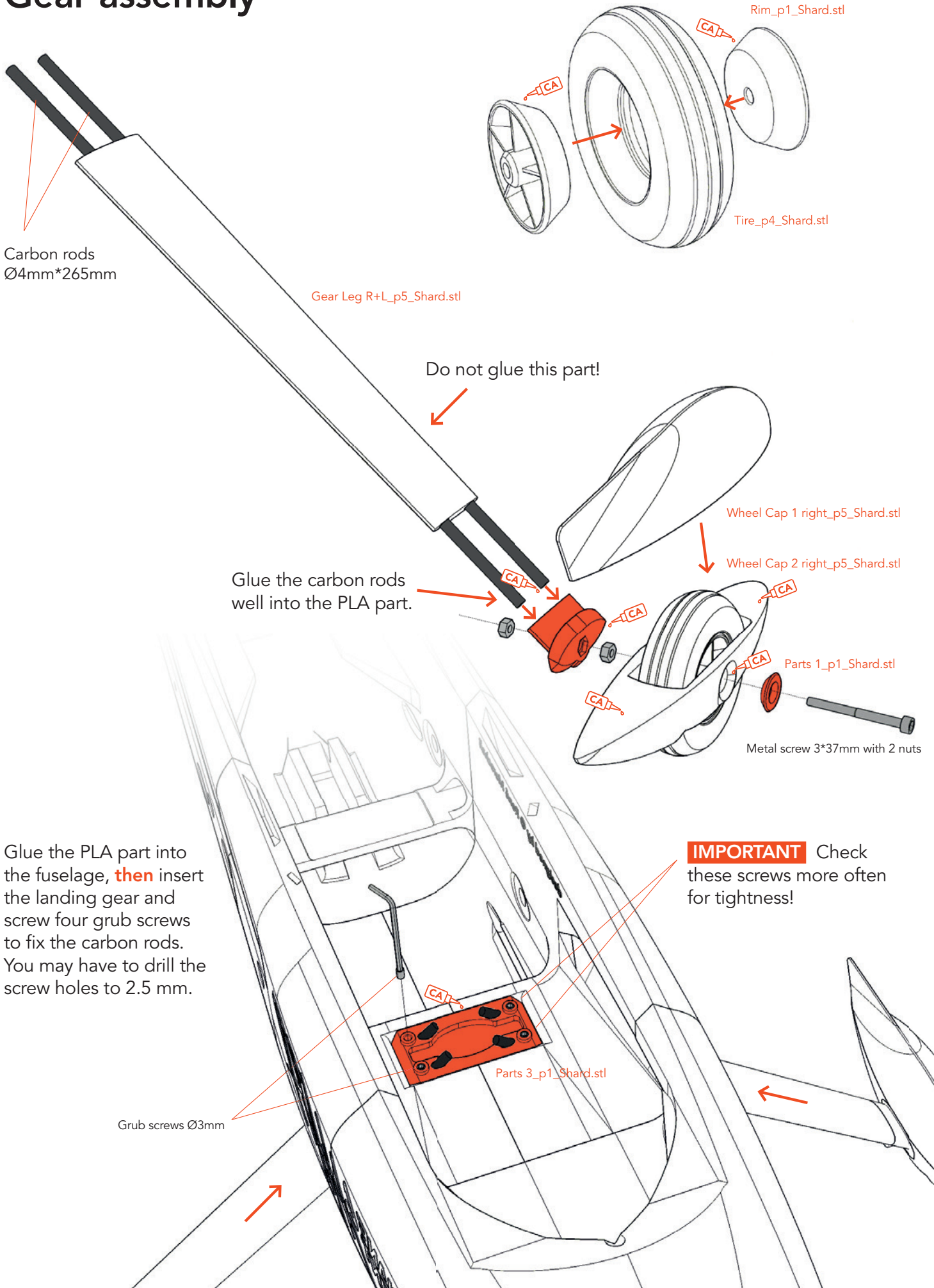

Carbon rods  
Ø4mm\*265mm

Gear Leg R+L\_p5\_Shard.stl

Rim\_p1\_Shard.stl

Tire\_p4\_Shard.stl

Do not glue this part!

Glue the carbon rods  
well into the PLA part.

Wheel Cap 1 right\_p5\_Shard.stl

Wheel Cap 2 right\_p5\_Shard.stl

Parts 1\_p1\_Shard.stl

Metal screw 3\*37mm with 2 nuts

Glue the PLA part into  
the fuselage, **then** insert  
the landing gear and  
screw four grub screws  
to fix the carbon rods.  
You may have to drill the  
screw holes to 2.5 mm.

**IMPORTANT** Check  
these screws more often  
for tightness!

Grub screws Ø3mm

Parts 3\_p1\_Shard.stl



# Gear assembly

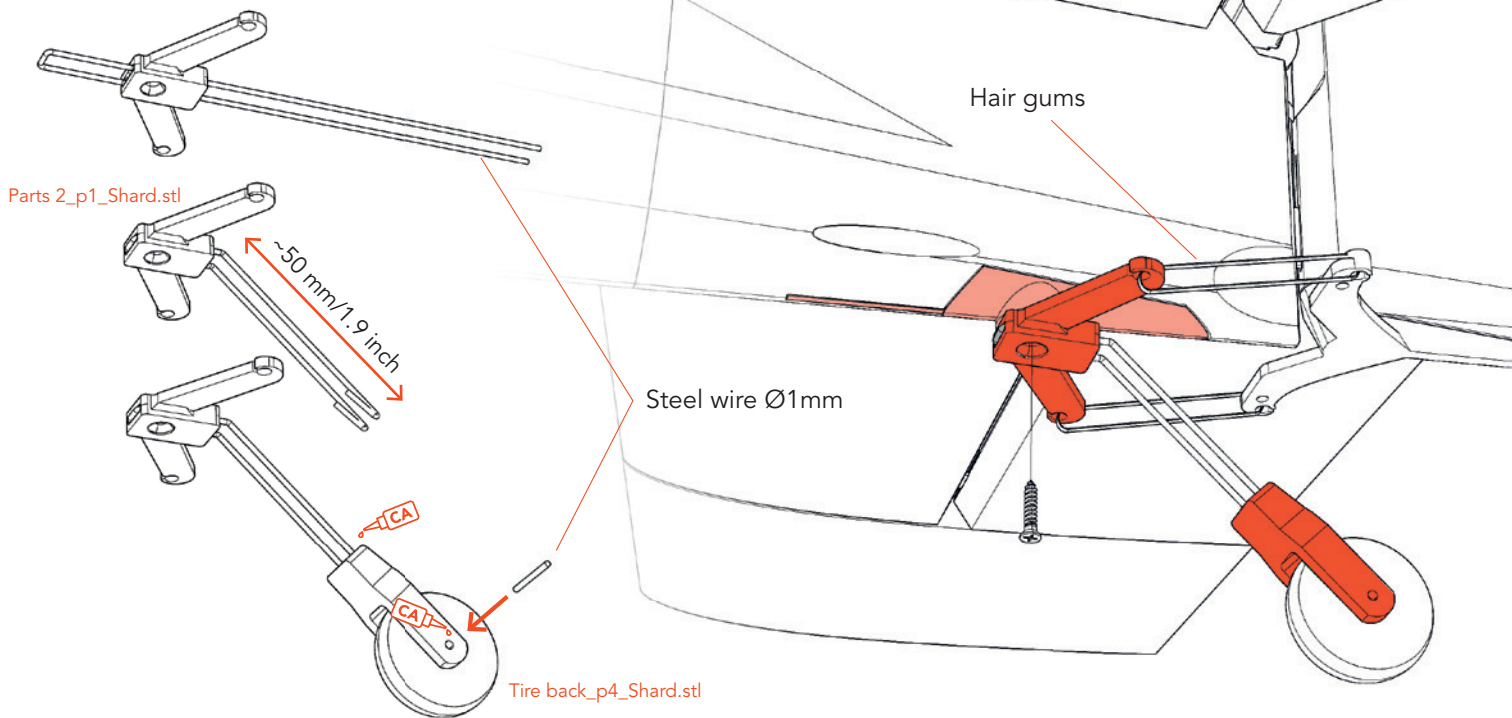

Bend the steel wire with needle nose pliers into a U-shape as shown in the picture, so that it can be put through the PLA part. Then bend the two ends about 45° down and the ends about 5 mm pointed. Make sure that the two wires are aligned exactly in the direction of flight and put the wheel mount on top and pour thin CA glue into the holes. Mount the tire with a piece of steel wire and apply a drop of medium CA glue to the outside of each tire. **Make sure that no glue gets inside the tire!**

Screw the gear tightly enough to the PLA part in fuselage 6 so that it can still be moved and connect the control horns with two hair gums.

# Controller assembly

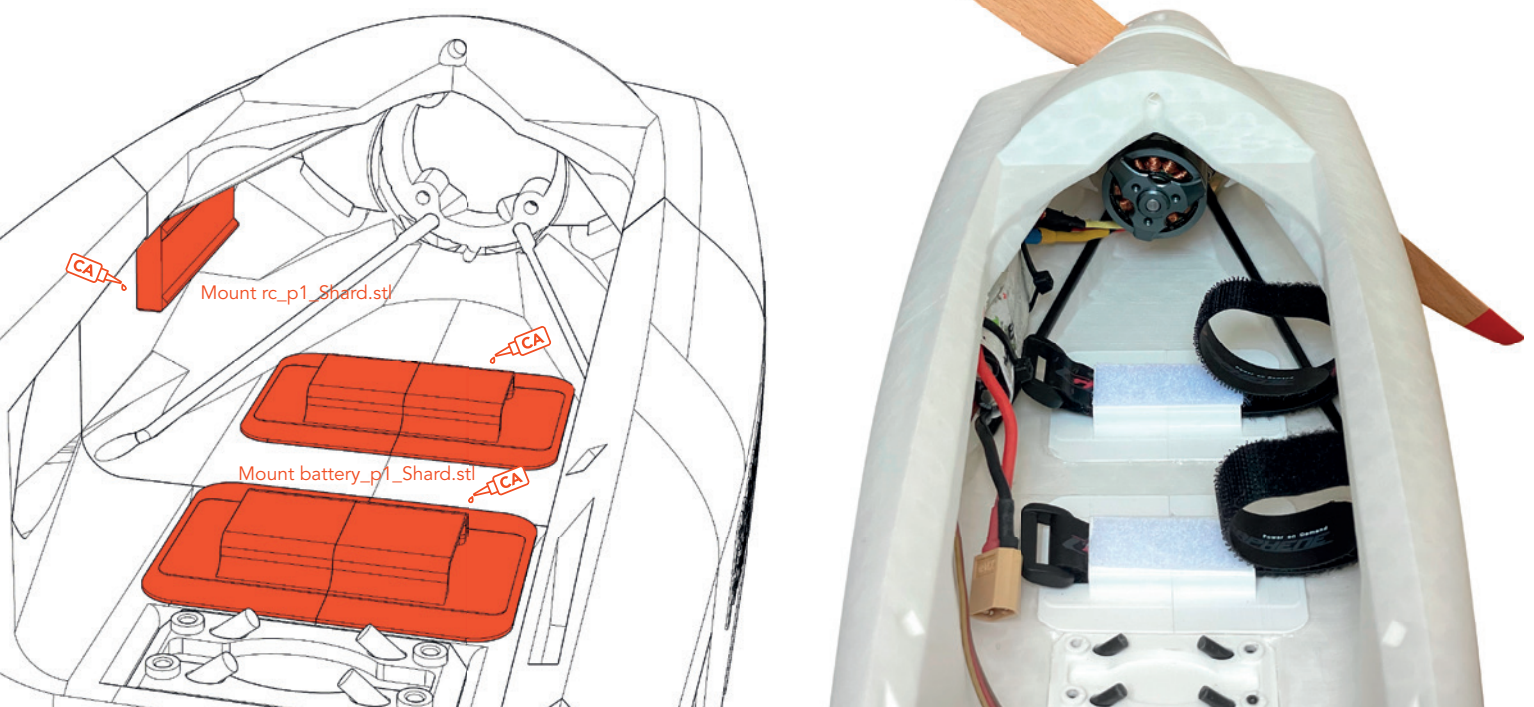

# Wing fastening

Glue the PLA parts to the fuselage as shown in the picture, as well as the X in the marks in the fuselage.

Tension the wings to the fuselage with the VarioShore/TPU Tension belts.

**Make sure that the carbon tubes and tube are not glued!**

Attach the receiver here with a velcro tape

X\_p5\_Shard.stl

Mount rc\_p1\_Shard.stl

Carbon rod  
Ø4mm\*170mm

Parts 3\_p1\_Shard.stl

Parts 4\_p1\_Shard.stl

Place the PLA discs on the carbon tube and apply just a drop of medium CA glue to the edge to fix it to the fuselage. remove the carbon tube and glue the disc well in place with thin CA glue.



# Motor mounting

Tape the four motor mounts firmly into the recesses in the fuselage. Screw the metal motor cross to the motor and the motor mount ring, then screw it to the fuselage.

It is advantageous to assemble the motor cross before gluing it in place, or you can use the motor tool to insert the nuts.

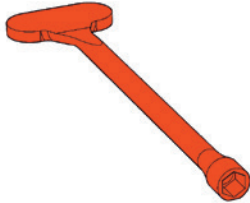

Metal screws 3\*20mm with stop nuts

Spinner plate\_p1\_Shard.stl

Spinner\_p5\_Shard.stl

For the spinner, add some thin CA glue to the screw hole area before assembly and cure with activator spray.

The cooling sheets are absolutely essential for engine cooling. The fuselage contains recesses that show the exact position. You should only glue them in after the motor has been installed.

**SAFETY FIRST** Use appropriate screws for motor mounting to ensure safe operation! Make sure the prop runs smoothly and does not generate vibrations. **Check regularly that the motor mounting is absolutely tight!**

Cooling sheets\_p1\_Shard.stl

# Canopy assembly

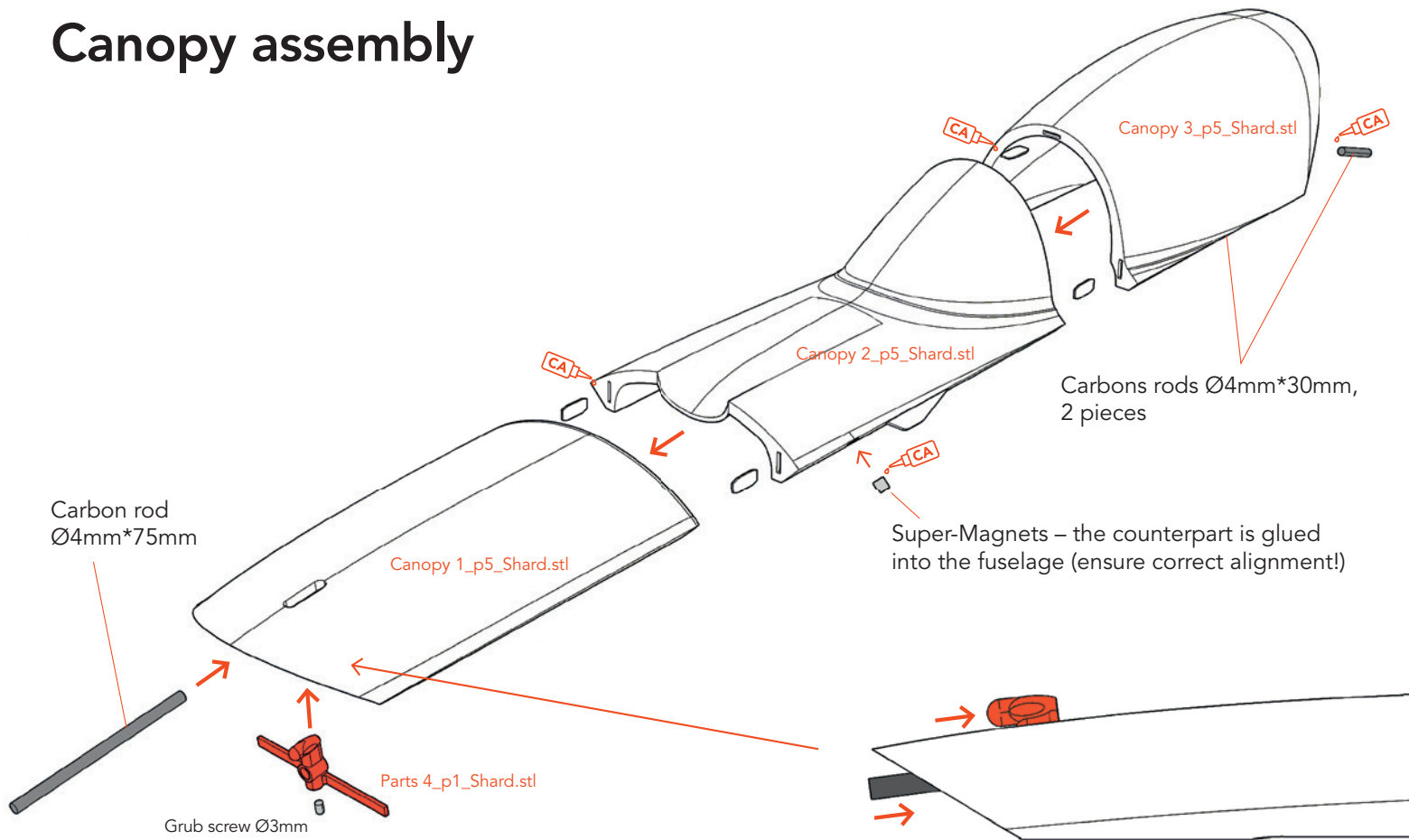

## Decals

In your download you will find a folder with templates for decals in various vector formats (in original size) as well as various suggestions for coloring.

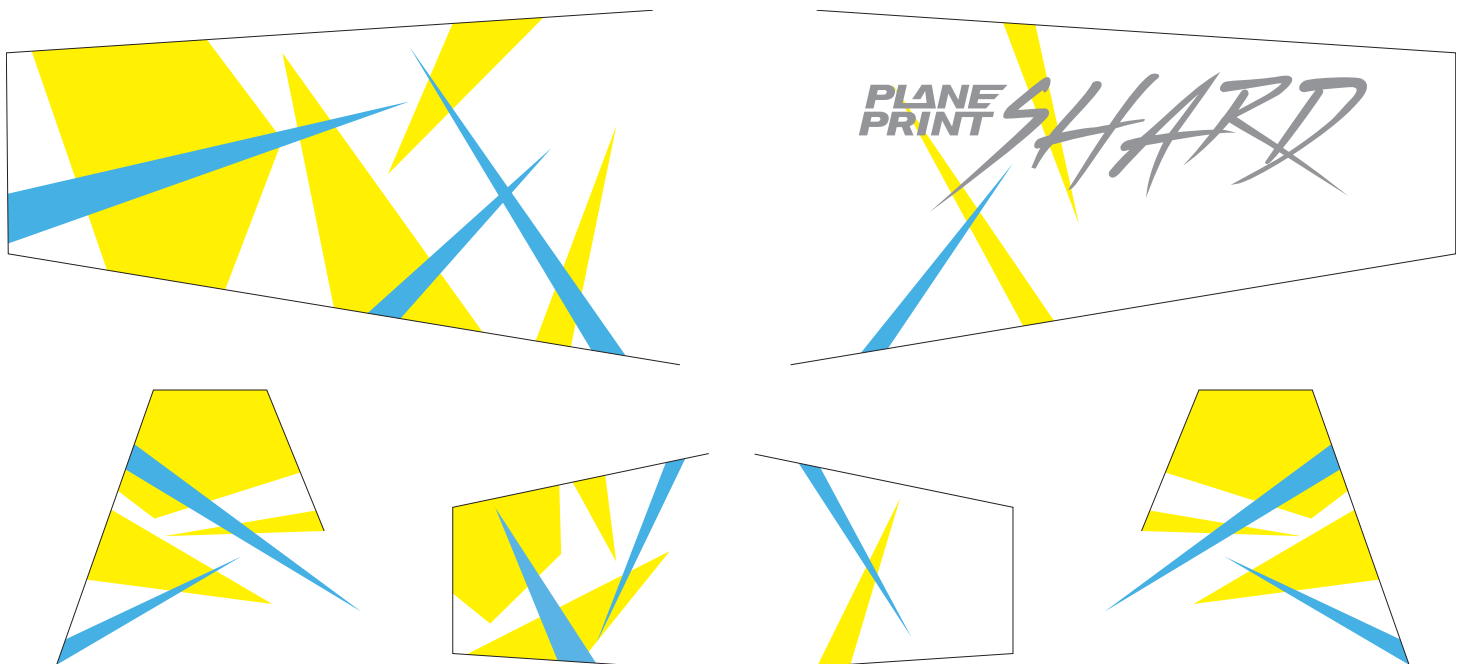



# Center of Gravity (CG)

There are two CG markings on the wing. The front one is 100 mm from the leading edge and is recommended for maiden flight. The rear one is 10 mm further back and is optimal for aerobatics. Where the CG is actually located on your SHARD depends on your personal preferences.

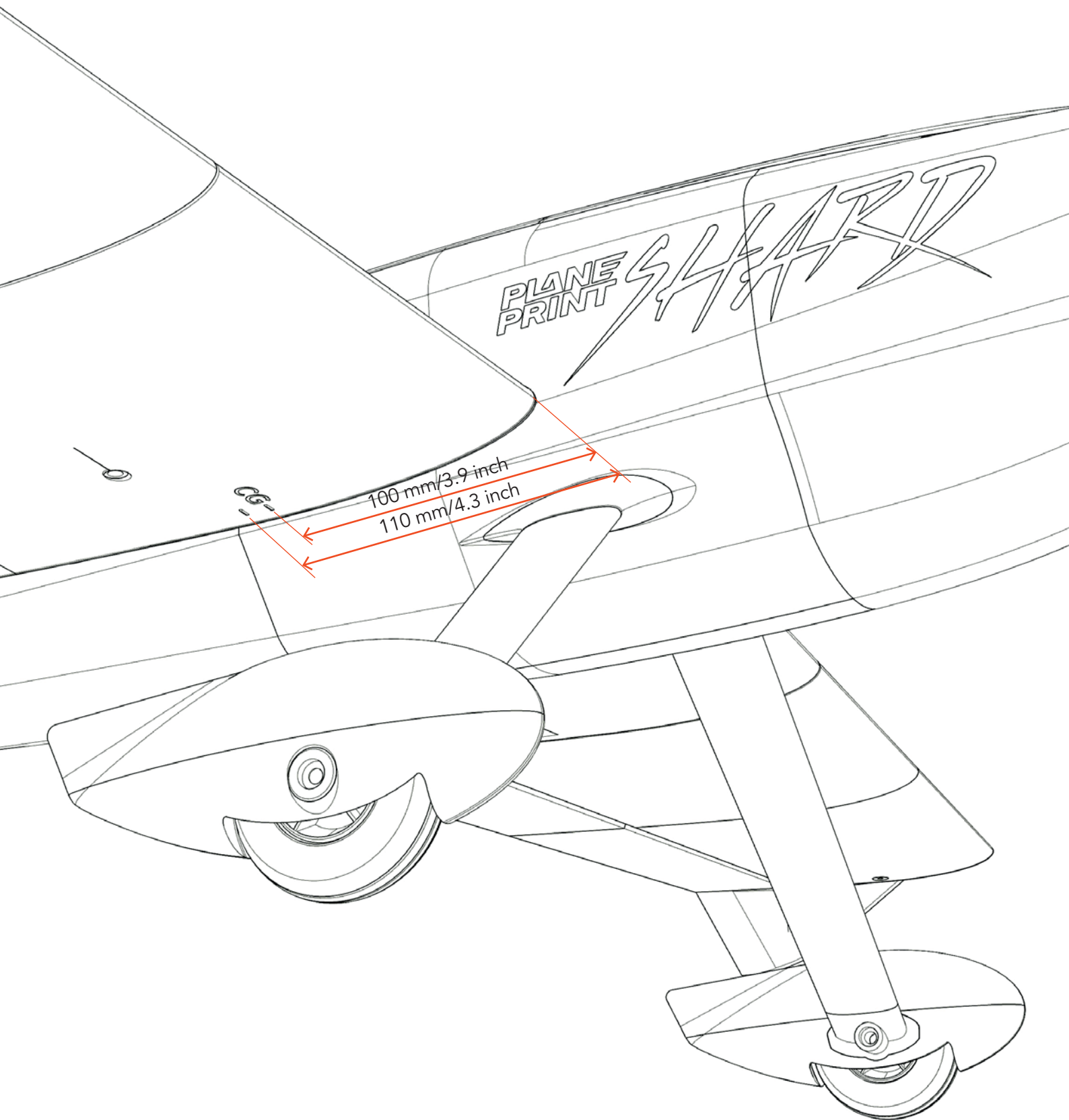

# Setting the servo travel

These basic settings are only a recommendation and can be changed according to your own preferences.

Flight phase	normal	3D acro
<b>ELEVATOR</b>	up/down 25 mm	up: 40 mm, down: 40 mm
<b>AILERON</b>	up/down 40 mm	up: 60 mm, down: 60 mm
<b>RUDDER</b>	left/right: 60 mm	left/right: maximum

## Expo setting

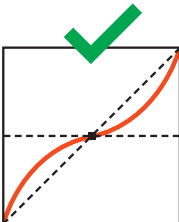
Flight phase	normal	3D acro	
<b>ELEVATOR</b>	60 %	60 %	 <p>(for some remote controls a minus has to be in front of the number)</p>
<b>AILERON</b>	40 %	50 %	
<b>RUDDER</b>	30 %	40 %	

## Technical specifications

**WINGSPAN** 1300 mm/51.2 inches

**LENGHT** 1300 mm/51.2 inches

**FLIGHT WEIGHT** 2.100 grams

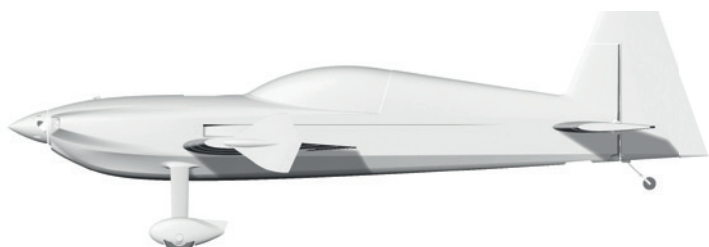



# Control Direction Test

Turn on the transmitter and connect the battery.

When checking the control directions, **look at the aircraft from behind.**

Elevator up

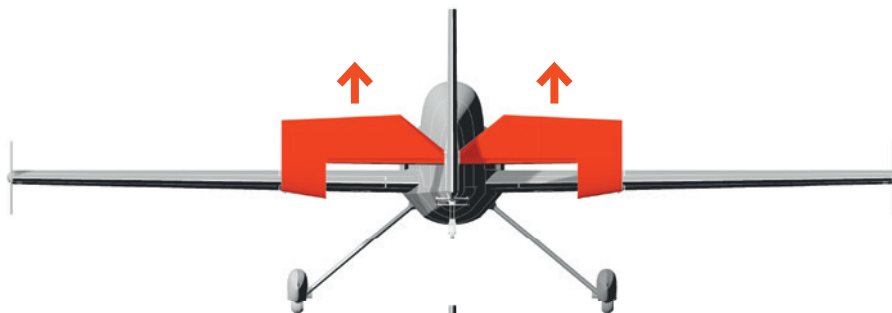

Elevator down

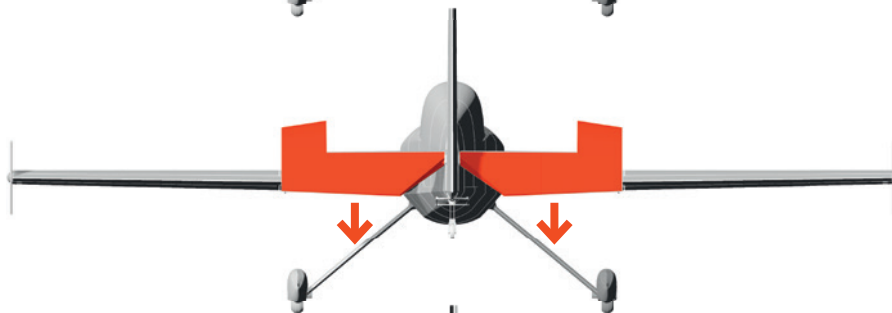

Aileron left

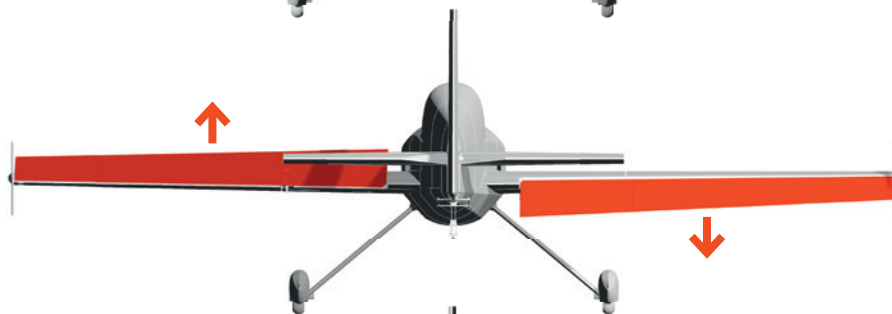
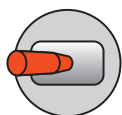

Aileron right

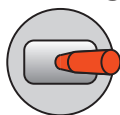

Rudder left

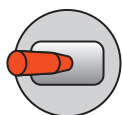

Rudder right

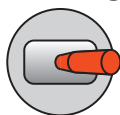

# AGE RECOMMENDATION 14+

**NOT FOR CHILDREN UNDER 14 YEARS.  
THIS IS NOT A TOY!**

By using the download data, an RC model airplane, called „model“ for short, can be manufactured using a 3D printer. As a user of this model, only you are responsible for safe operation that does not endanger you or others, or that does not damage the model or property of others.

PLANEPRINT.com assumes no responsibility for damage to persons and property caused by pressure, transport or use of the product. Filaments, printing supplies, hardware or consumables that can not be used after faulty 3D printing will not be replaced by PLANEPRINT.com in any way.

When operating, always keep a safe distance from your model in all directions to avoid collisions and injuries.

This model is controlled by a radio signal. Radio signals can be disturbed from outside without being able to influence it. Interference can lead to a temporary loss of control.

Always operate your model on open terrains, far from cars, traffic and people.

Always follow the instructions and warnings for this product and any optional accessories (servos, receivers, motors, propellers, chargers, rechargeable batteries, etc.) carefully.

Keep all chemicals, small parts and electrical components out of the reach of children.

Avoid water contact with all components that are not specially designed and protected. Moisture damages the electronics.

Never take an item of the model or accessory in your mouth as this can lead to severe injuries or even death.

Never operate your model with low batteries in the transmitter or model.

Always keep the model in view and under control. Use only fully charged batteries.

Always keep the transmitter switched on when the model is switched on.

Always remove the battery before disassembling the model.

Keep moving parts clean and dry at all times.

Always allow the parts to cool before touching them.

Always remove the battery after use.

Make sure that the Failsafe is properly set before the flight.

Never operate the model with damaged wiring.

Never touch moving parts.

We develop our models to the best of our knowledge and belief. We accept no liability for consequential damage and injuries caused by improper use or incorrectly printed parts. **Please be careful when handling motors, batteries and propellers** and only move your model with insurance and in approved places!

**PLANE  
PRINT.com**

© PLANEPRINT.com, A-6021 Innsbruck, Conradstraße 6, info@planeprint.com

© Design STL files by René Marschall • Layout: marschall designlab, marschall.cc

All STL are subject to the copyright of René Marschall. It is not allowed to mold and rebuild Planeprint models with other materials (carbon, wood ...).