

# EAGLE



**NOTE:** Slicing only works with CURA!



You can find the STL data at [www.planeprint.com](http://www.planeprint.com)

# PRINTING THE PARTS – PRINTING PROFILES

You may wonder why this 3D model is suitable exclusively for CURA right?

The most important thing about small RC model airplanes is always the ratio of size to weight. The lighter a model is, the better its flight characteristics and also the flight time is significantly increased.

With our unique design process, we manage to make Weights relevant items in a **true 1-wall printing process** for the outer skin but also for the filling offer. So we save weight while maintaining the necessary stability.

Here we show you how to get started from a standard CURA profile Make settings. For this model we only need 4, easy to create profiles.

It is **absolutely necessary** to observe the information provided by **PLANEPRINT.com** in order: to slice the component correctly. However, it may make sense to perfect your 3D printing by additionally performing several hiring activities depending on your printer and the filament used.

For slicing all Planeprint models, four profiles have to be created in Cura:

PROFILE P1\_fullbody  
PROFILE P2\_hollowbody  
PROFILE P3\_surface  
PROFILE P4\_flex

You can find the description at  
[www.planeprint.com/print](http://www.planeprint.com/print)

## IMPORTANT FOR THE 1-WALL-PRINT!

In order to print airfoils of the lowest possible weight with high stability, it is necessary to print with only one wall line (Nozzle 0.4 mm). Decisive here is the adhesion between the layers! To achieve this, you must print at a much higher temperature than normal. As a **guideline**, 230 ° C is a good starting point. The parts-cooling fan should be set to 0% or a maximum of 20%. Since not every printer works the same, it may be necessary to make small adjustments to these settings.



The development of a complex, airworthy RC flight model to express on any standard 3D printer is a very complex and extensive process. Therefore, we appeal to your fairness not to forward the STL data you have acquired to third parties. Our STL files are provided with indelible copyright watermarks that can be verified at any time.

**Thank you for your understanding and have fun with your PLANEPRINT MODEL!**

# PROFILE P1\_FULLBODY

The following parts must be sliced with the PROFILE P1\_FULLBODY.  
Please note the additional settings for the individual parts!

## eagle-Motormount-profile1.stl

**MATERIAL** PLA, Weight: ~ 2 g

### ADDITIONAL SETTINGS

None required



## eagle-Servomount-profile1.stl

**MATERIAL** PLA, ~ 2 g

### ADDITIONAL SETTINGS

None required

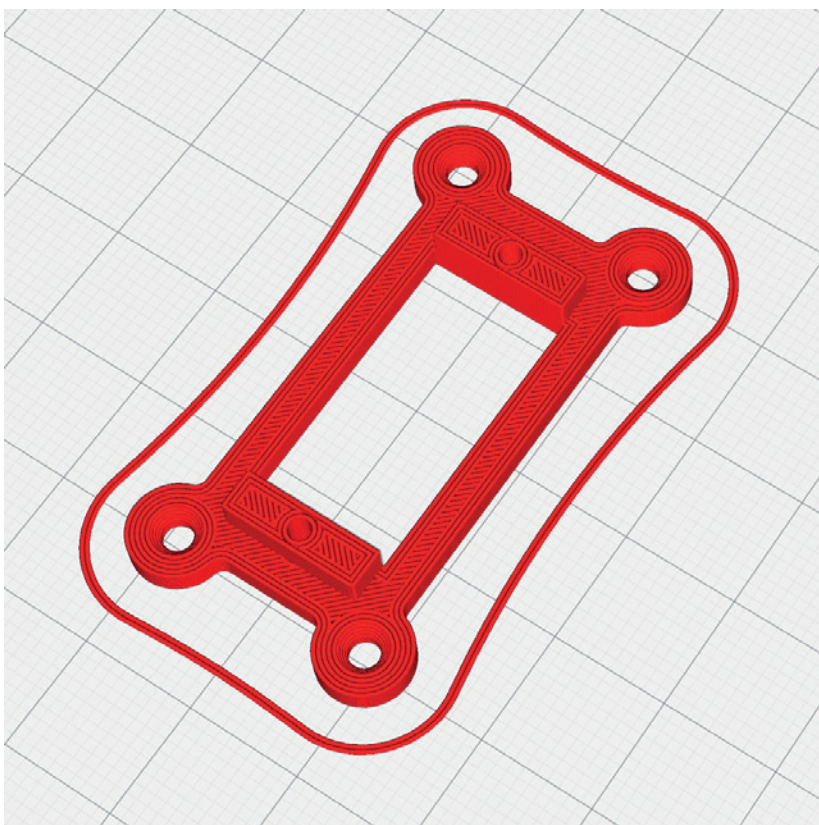

# PROFILE P1\_FULLBODY

The following parts must be sliced with the PROFILE P1\_FULLBODY.  
Please note the additional settings for the individual parts!

## eagle-Tail hinge-profile1.stl

**MATERIAL** PLA, ~ 7 g

### ADDITIONAL SETTINGS

None required

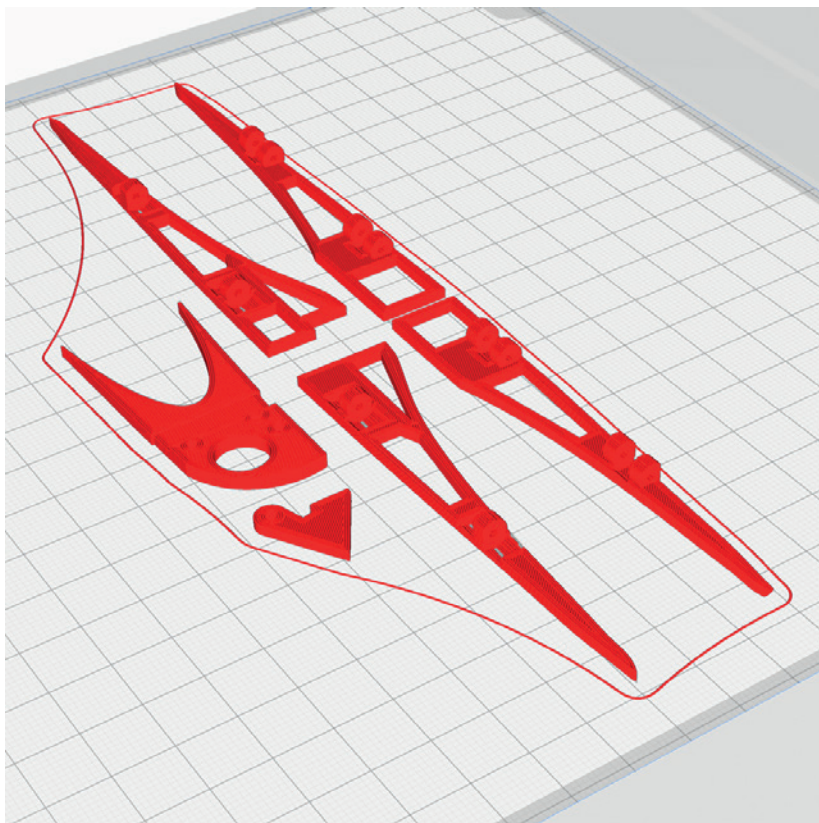

## eagle-wingservo\_xxx-profile1.stl

**MATERIAL** PLA, ~ 2 g

### ADDITIONAL SETTINGS

None required

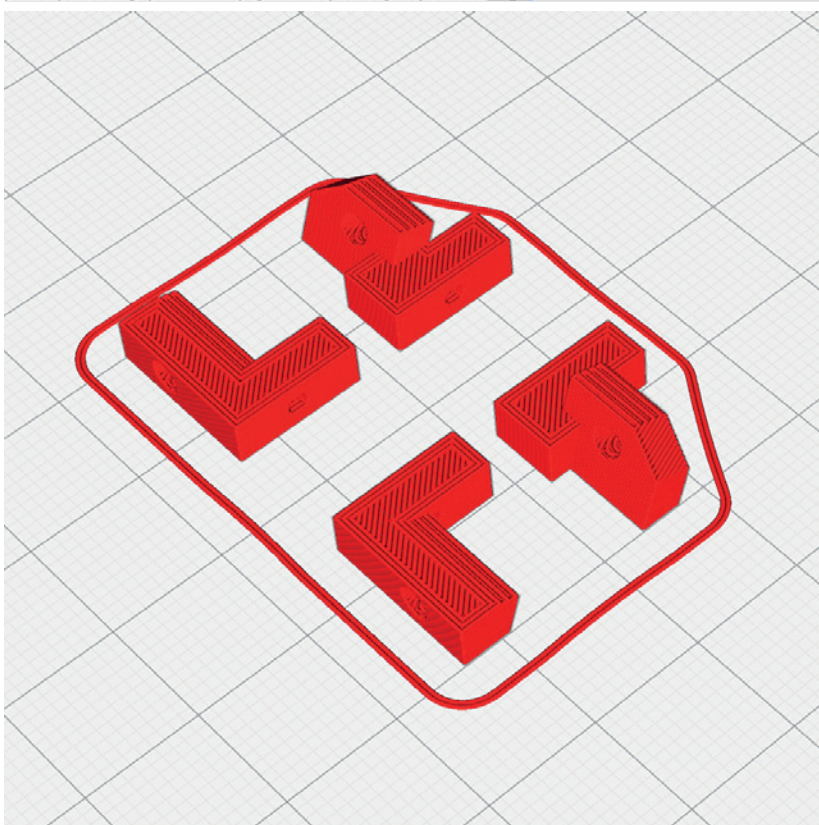

# PROFILE P1\_FULLBODY

The following parts must be sliced with the PROFILE P1\_FULLBODY.  
Please note the additional settings for the individual parts!

eagle-Parts-profile1.stl

**MATERIAL** PLA, ~ 5 g

**ADDITIONAL SETTINGS**

None required

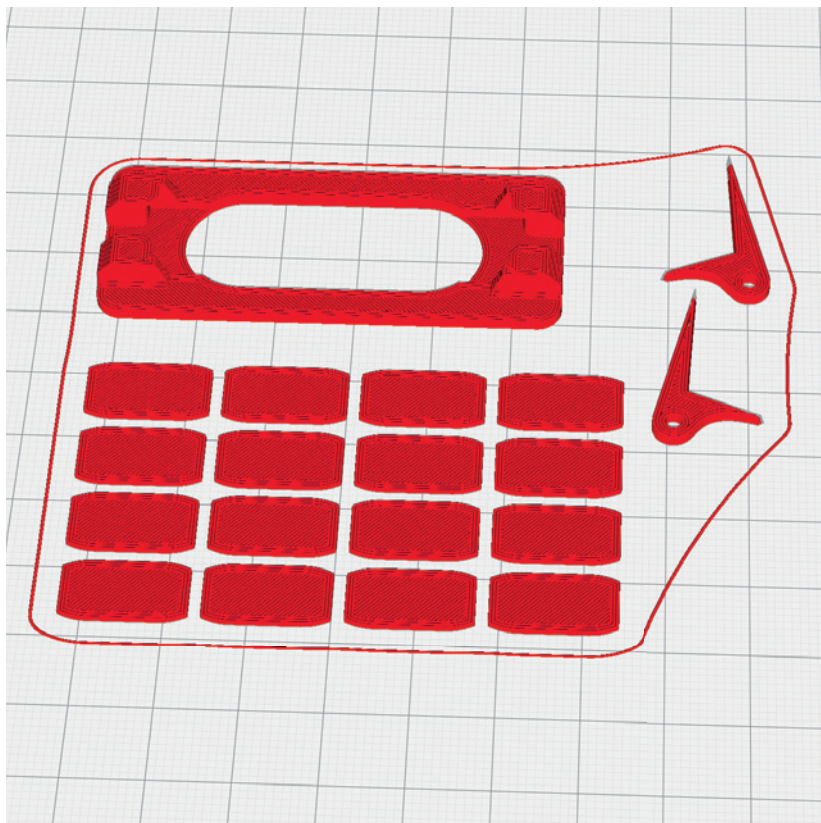

# PROFILE P3\_SURFACE normal PLA

The following parts must be sliced with the PROFILE P3\_SURFACE (1-wall-print).

**Please note the additional settings for the individual parts!**

**PLEASE NOTE** In profile P3\_SURFACE, there should not be more than one STL on the buildplate at the same time, otherwise slicing errors can occur! Depending on your printer, a brim may not be required.

## eagle-Head-profile3.stl

**MATERIAL** PLA, ~ 28 g

### ADDITIONAL SETTINGS

None required

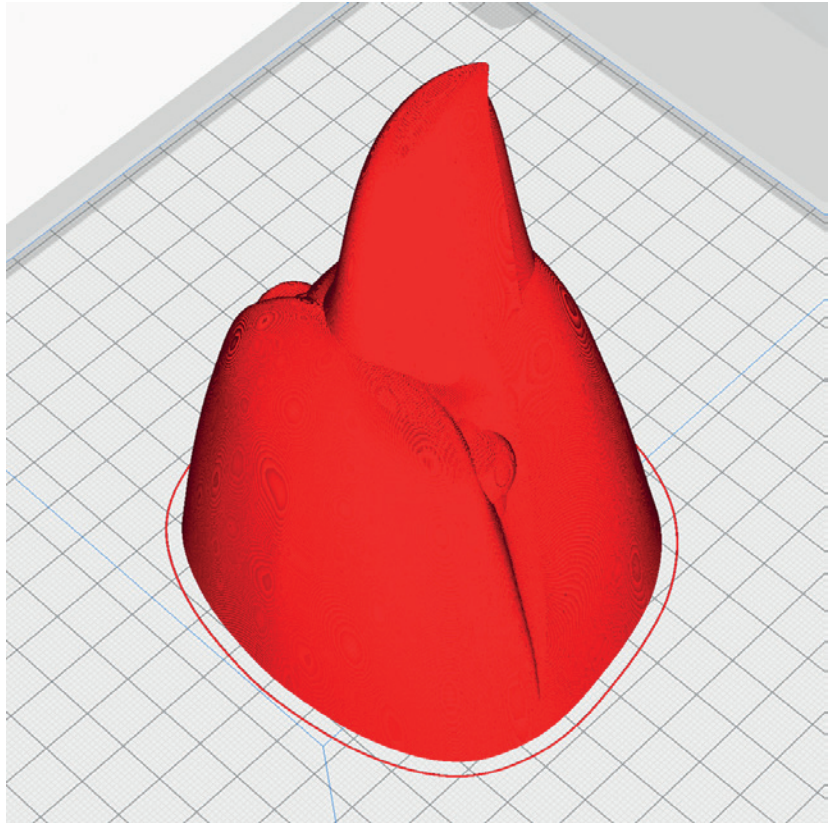

## eagle-Motorhead-profile3.stl

**MATERIAL** PLA, ~ 28 g

### ADDITIONAL SETTINGS

None required

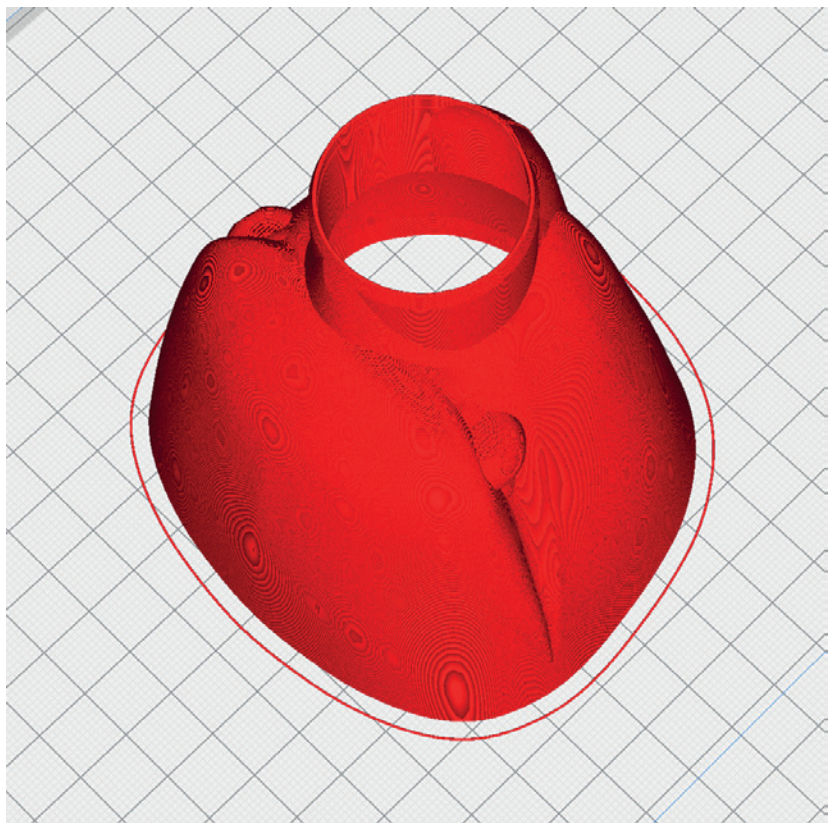

# PROFILE P3\_SURFACE normal PLA

The following parts must be sliced with the PROFILE P3\_SURFACE (1-wall-print).

**Please note the additional settings for the individual parts!**

**PLEASE NOTE** In profile P3\_SURFACE, there should not be more than one STL on the buildplate at the same time, otherwise slicing errors can occur! Depending on your printer, a brim may not be required.

## eagle-Body1-profile3.stl

**MATERIAL** PLA, ~ 88 g

### ADDITIONAL SETTINGS

None required

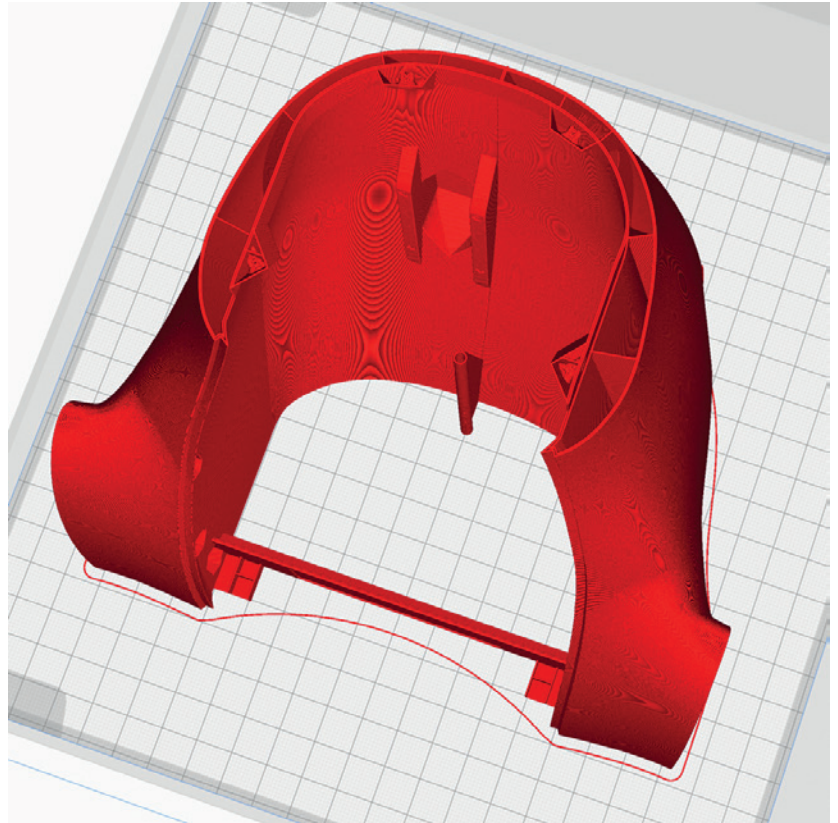

## eagle-Wing1-left/right-profile3.stl

**MATERIAL** PLA, ~ 37 g

### ADDITIONAL SETTINGS

None required

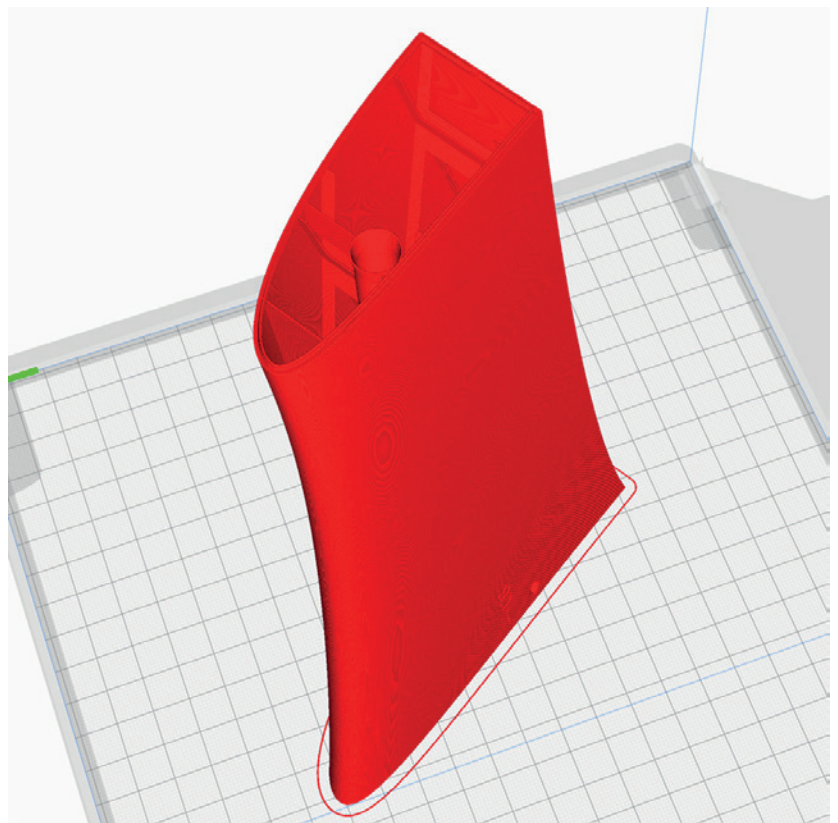

# PROFILE P3\_SURFACE normal PLA

The following parts must be sliced with the PROFILE P3\_SURFACE (1-wall-print).

**Please note the additional settings for the individual parts!**

**PLEASE NOTE** In profile P3\_SURFACE, there should not be more than one STL on the buildplate at the same time, otherwise slicing errors can occur! Depending on your printer, a brim may not be required.

## eagle-Wing2-left/right-profile3.stl

**MATERIAL** PLA, ~ 33 g

### ADDITIONAL SETTINGS

None required

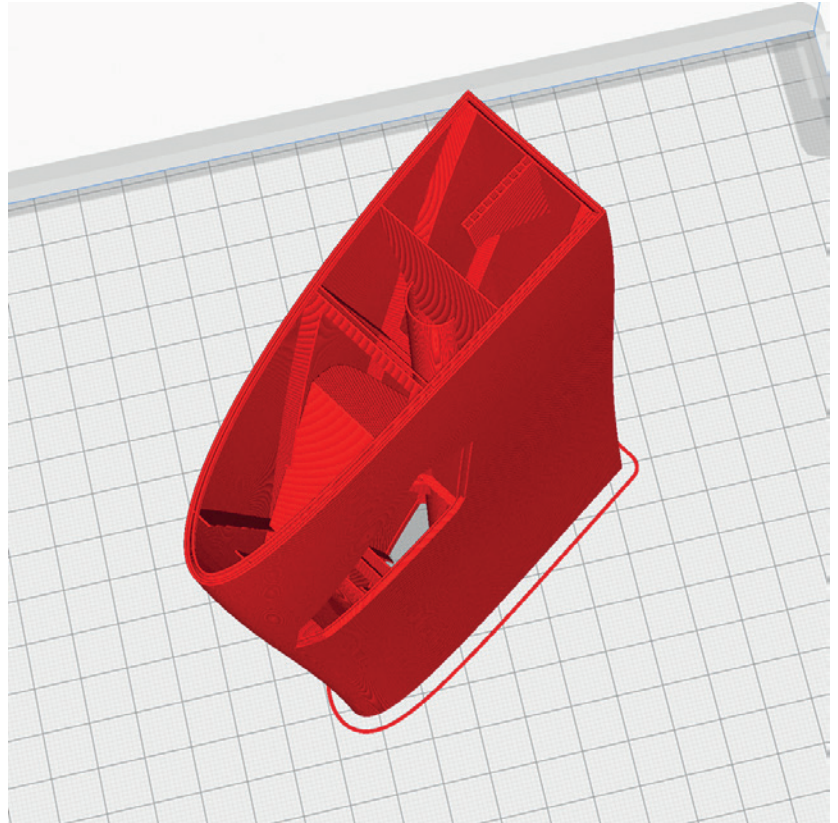

## eagle-Wing3-both-profile3.stl

**MATERIAL** PLA, ~ 33 g

### ADDITIONAL SETTINGS

None required

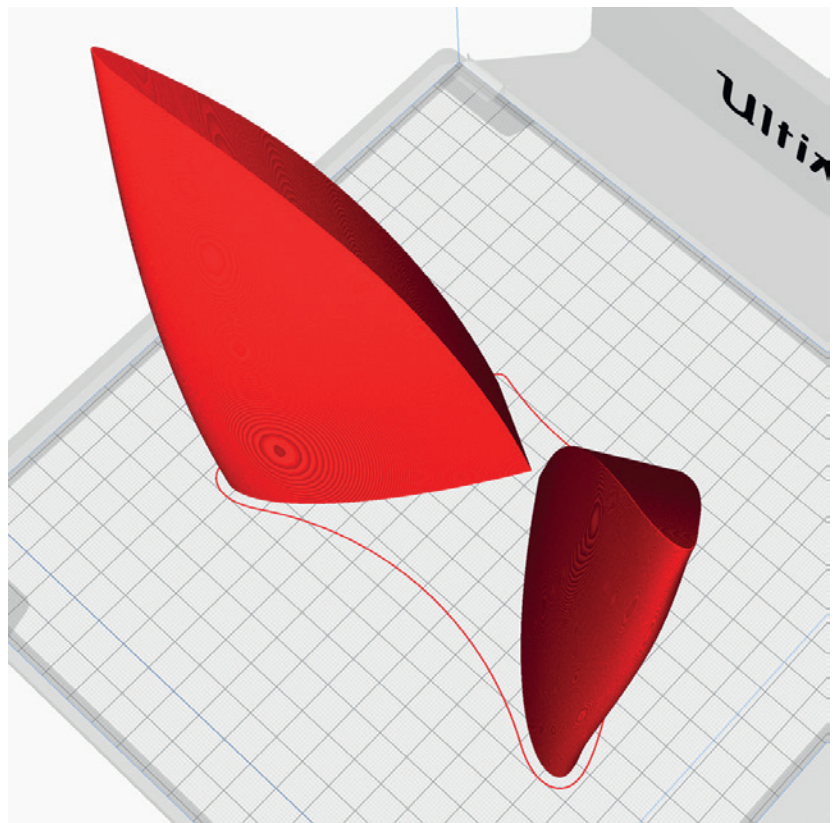



# PROFILE P3\_SURFACE normal PLA

The following parts must be sliced with the PROFILE P3\_SURFACE (1-wall-print).

**Please note the additional settings for the individual parts!**

**PLEASE NOTE** In profile P3\_SURFACE, there should not be more than one STL on the buildplate at the same time, otherwise slicing errors can occur! Depending on your printer, a brim may not be required.

**eagle-Servocovers-profile3.stl**

**MATERIAL** PLA, ~ 2 g

**ADDITIONAL SETTINGS**

None required

If you have problems with printing, there is a combined version in the Individual parts folder.

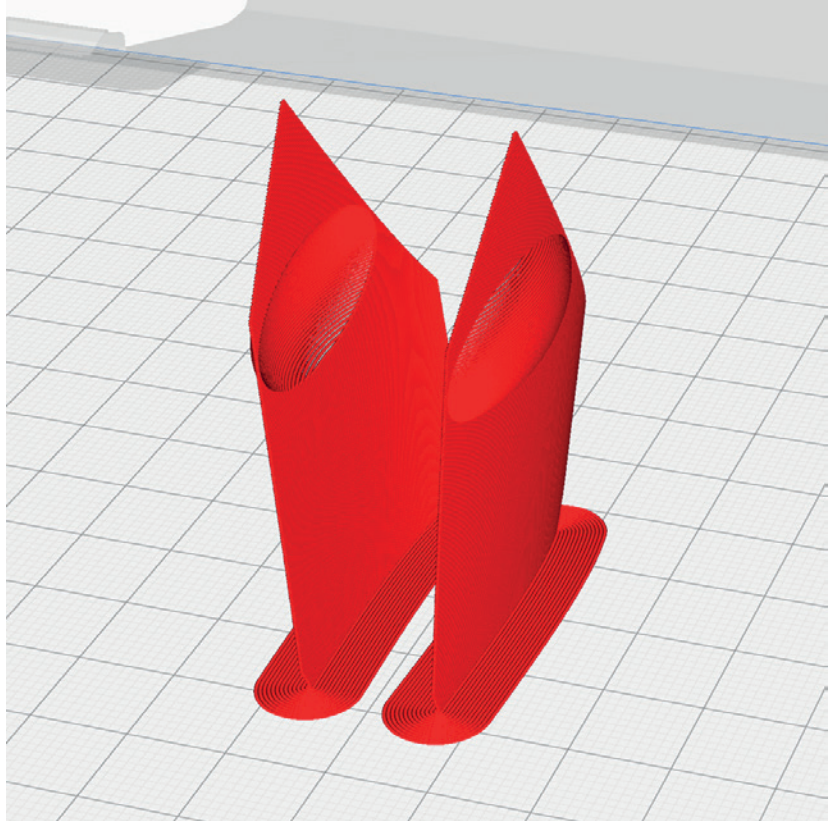

# PROFILE P3\_SURFACE Light-Weight LW-PLA

The following parts must be sliced with the PROFILE P3\_SURFACE (1-wall-print).

**Please note the additional settings for the individual parts!**

**PLEASE NOTE** In profile P3\_SURFACE, there should not be more than one STL on the buildplate at the same time, otherwise slicing errors can occur! Depending on your printer, a brim may not be required.

## eagle-Body2\_LW-profile3.stl

**MATERIAL** LW-PLA, ~ 105 g\*

\*Display in Cura. The actual weight is then 60% of this.

### ADDITIONAL SETTINGS

- Setting Profile3\_Surface
- Flow 60 % or less
- Higher nozzle temperature

The optimal weight and sufficient strength is achieved with 60 % flow. Increase the temperature until the wall thickness is 0.4 to 0.5 mm. (We print at 235° and 60% flow).

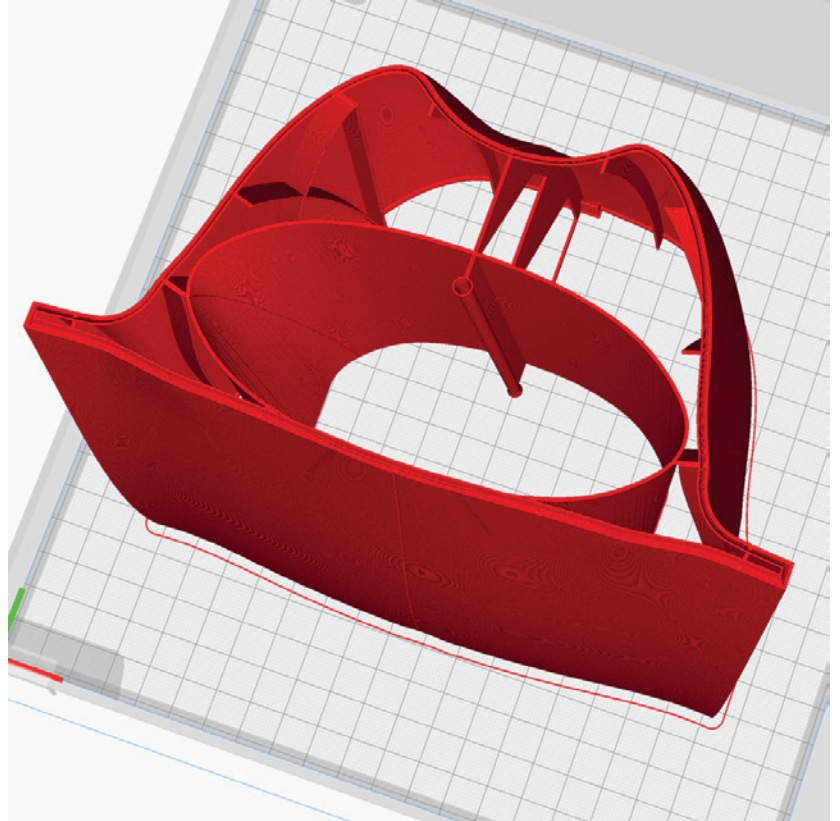

## eagle-Body3\_LW-profile3.stl

**MATERIAL** LW-PLA, ~ 38 g\*

\*Display in Cura. The actual weight is then 60% of this.

### ADDITIONAL SETTINGS

- Setting Profile3\_Surface
- Flow 60 % or less
- Higher nozzle temperature

The optimal weight and sufficient strength is achieved with 60 % flow. Increase the temperature until the wall thickness is 0.4 to 0.5 mm. (We print at 235° and 60% flow).

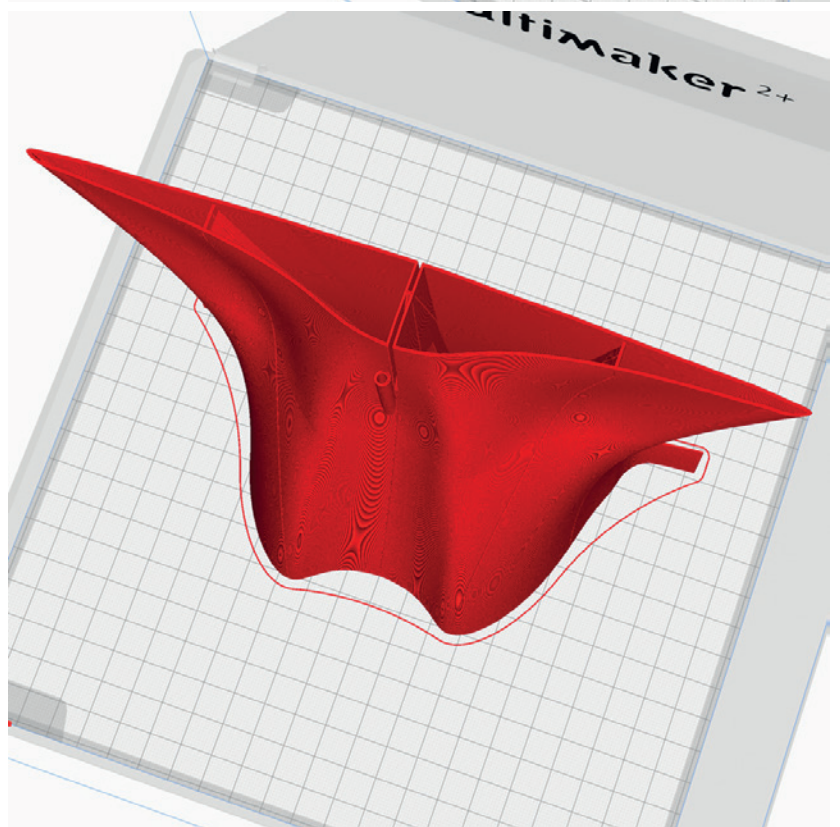

# PROFILE P3\_SURFACE Light-Weight LW-PLA

The following parts must be sliced with the PROFILE P3\_SURFACE (1-wall-print).

**Please note the additional settings for the individual parts!**

**PLEASE NOTE** In profile P3\_SURFACE, there should not be more than one STL on the buildplate at the same time, otherwise slicing errors can occur! Depending on your printer, a brim may not be required.

## eagle-Aileron1\_LW-left/right-profile3.stl

**MATERIAL** LW-PLA, ~ 18 g\*

\*Display in Cura. The actual weight is then 60% of this.

### ADDITIONAL SETTINGS

- Setting Profile3\_Surface
- Flow 60 % or less
- Higher nozzle temperature

The optimal weight and sufficient strength is achieved with 60 % flow. Increase the temperature until the wall thickness is 0.4 to 0.5 mm. (We print at 235° and 60% flow).

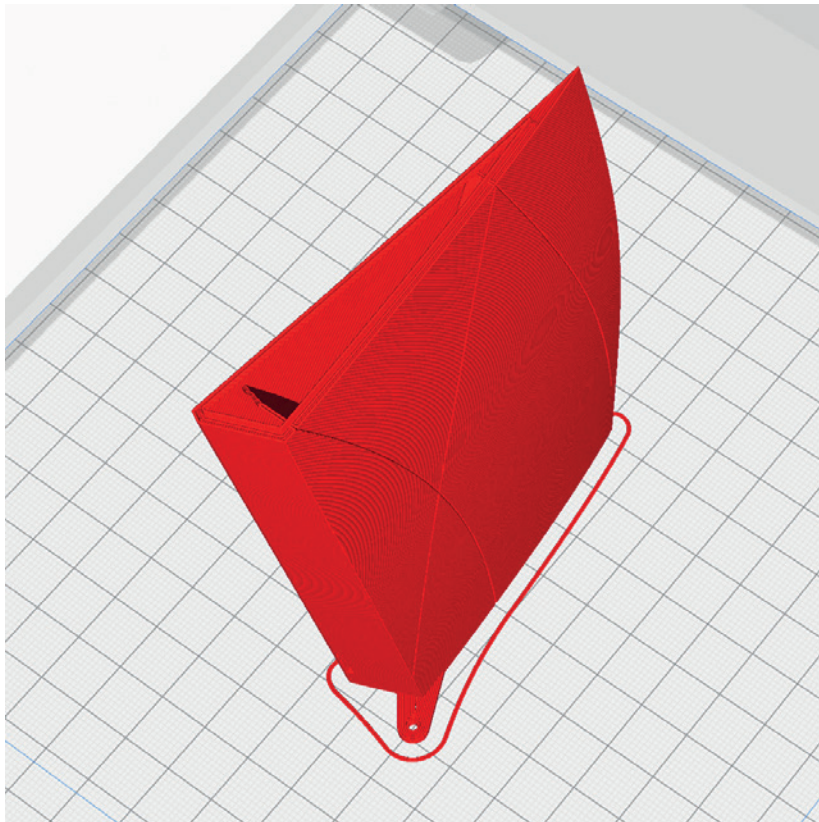

## eagle-Aileron2\_LW-left/right-profile3.stl

**MATERIAL** LW-PLA, ~ 15 g\*

\*Display in Cura. The actual weight is then 60% of this.

### ADDITIONAL SETTINGS

- Setting Profile3\_Surface
- Flow 60 % or less
- Higher nozzle temperature

The optimal weight and sufficient strength is achieved with 60 % flow. Increase the temperature until the wall thickness is 0.4 to 0.5 mm. (We print at 235° and 60% flow).

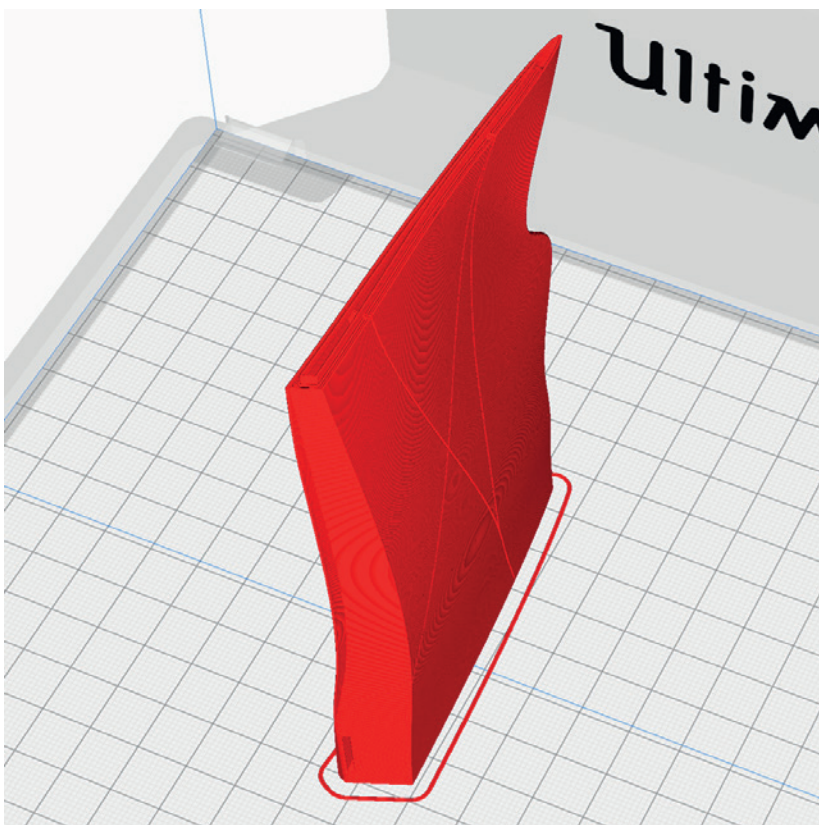

# PROFILE P3\_SURFACE Light-Weight LW-PLA

The following parts must be sliced with the PROFILE P3\_SURFACE (1-wall-print).

**Please note the additional settings for the individual parts!**

**PLEASE NOTE** In profile P3\_SURFACE, there should not be more than one STL on the buildplate at the same time, otherwise slicing errors can occur! Depending on your printer, a brim may not be required.

## eagle-Aileron3\_LW-left/right-profile3.stl

**MATERIAL** LW-PLA, ~ 10 g\*

\*Display in Cura. The actual weight is then 60% of this.

### ADDITIONAL SETTINGS

- Setting Profile3\_Surface
- Flow 60 % or less
- Higher nozzle temperature

The optimal weight and sufficient strength is achieved with 60 % flow. Increase the temperature until the wall thickness is 0.4 to 0.5 mm. (We print at 235° and 60% flow).

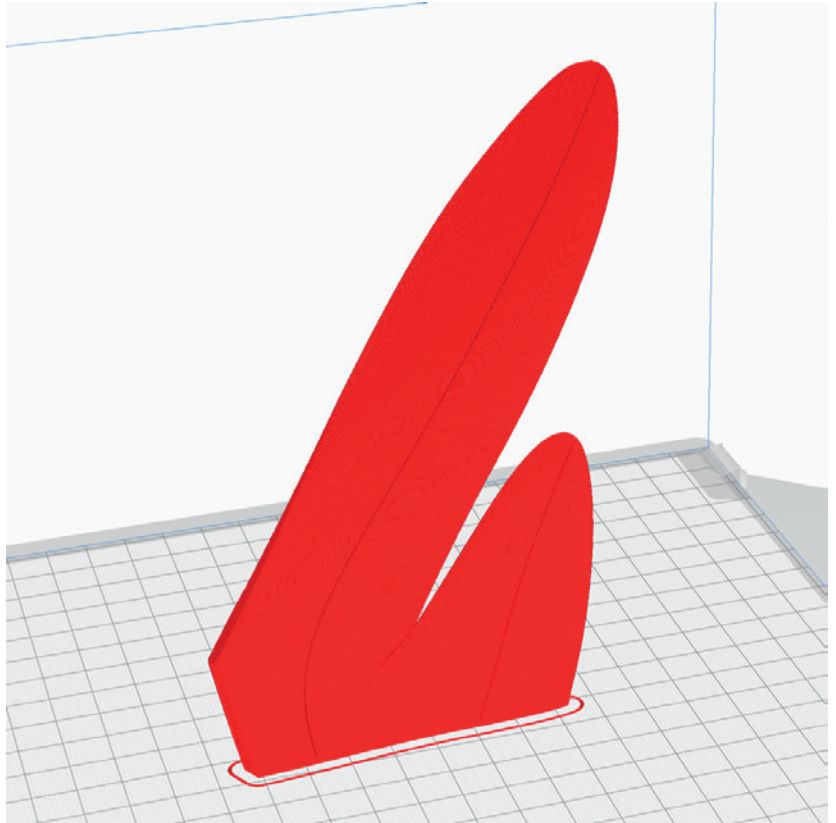

## eagle-Cover\_LW-profile3.stl

**MATERIAL** LW-PLA, ~ 21 g\*

\*Display in Cura. The actual weight is then 60% of this.

### ADDITIONAL SETTINGS

- Setting Profile3\_Surface
- Flow 60 % or less
- Higher nozzle temperature

The optimal weight and sufficient strength is achieved with 60 % flow. Increase the temperature until the wall thickness is 0.4 to 0.5 mm. (We print at 235° and 60% flow).

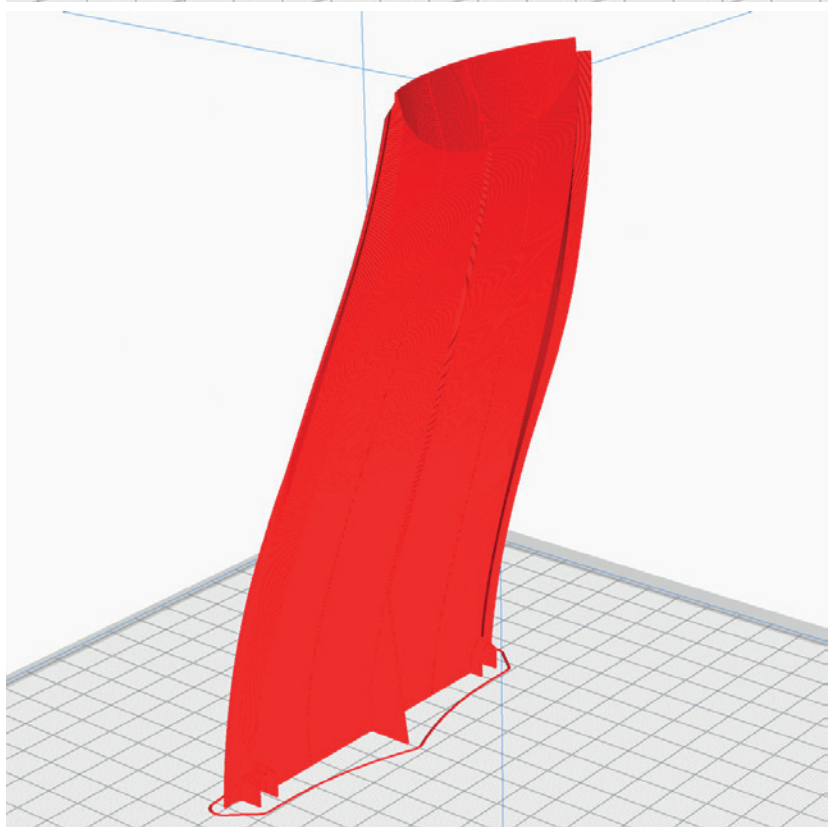

# PROFILE P3\_SURFACE Light-Weight LW-PLA

The following parts must be sliced with the PROFILE P3\_SURFACE (1-wall-print).

**Please note the additional settings for the individual parts!**

**PLEASE NOTE** In profile P3\_SURFACE, there should not be more than one STL on the buildplate at the same time, otherwise slicing errors can occur! Depending on your printer, a brim may not be required.

## eagle-Tail-left/right\_LW-profile3.stl

**MATERIAL** LW-PLA, ~ 23 g\*

\*Display in Cura. The actual weight is then 60% of this.

### ADDITIONAL SETTINGS

- Setting Profile3\_Surface
- Flow 60 % or less
- Higher nozzle temperature

The optimal weight and sufficient strength is achieved with 60 % flow. Increase the temperature until the wall thickness is 0.4 to 0.5 mm. (We print at 235° and 60% flow).

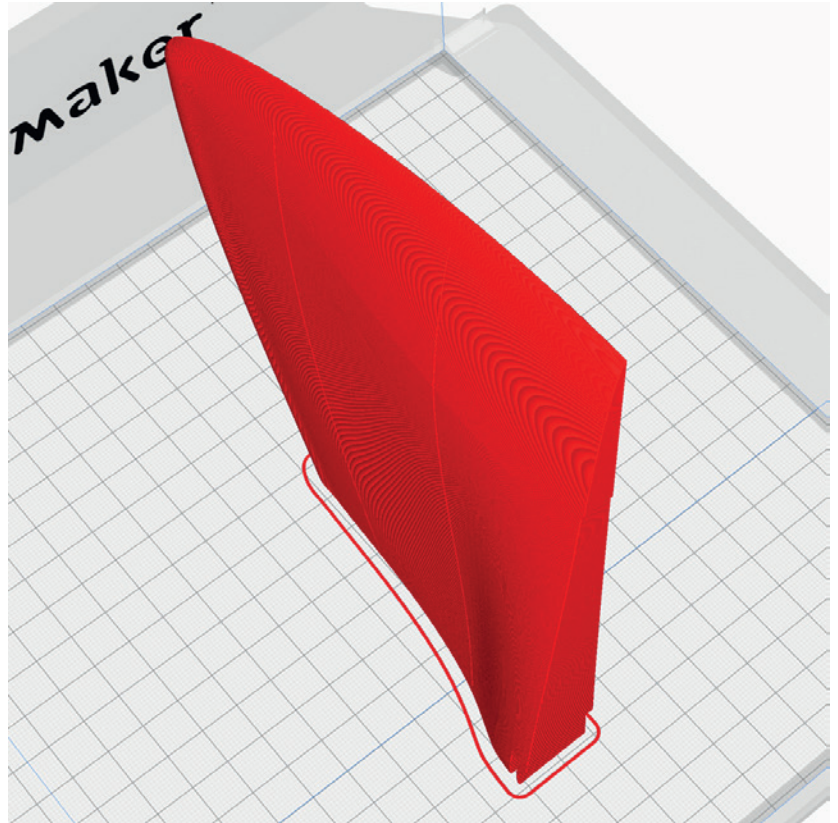

## eagle-Wing4\_LW-left/right-profile3.stl

**MATERIAL** LW-PLA, ~ 74 g\*

\*Display in Cura. The actual weight is then 60% of this.

### ADDITIONAL SETTINGS

- Setting Profile3\_Surface
- Flow 60 % or less
- Higher nozzle temperature

The optimal weight and sufficient strength is achieved with 60 % flow. Increase the temperature until the wall thickness is 0.4 to 0.5 mm. (We print at 235° and 60% flow).

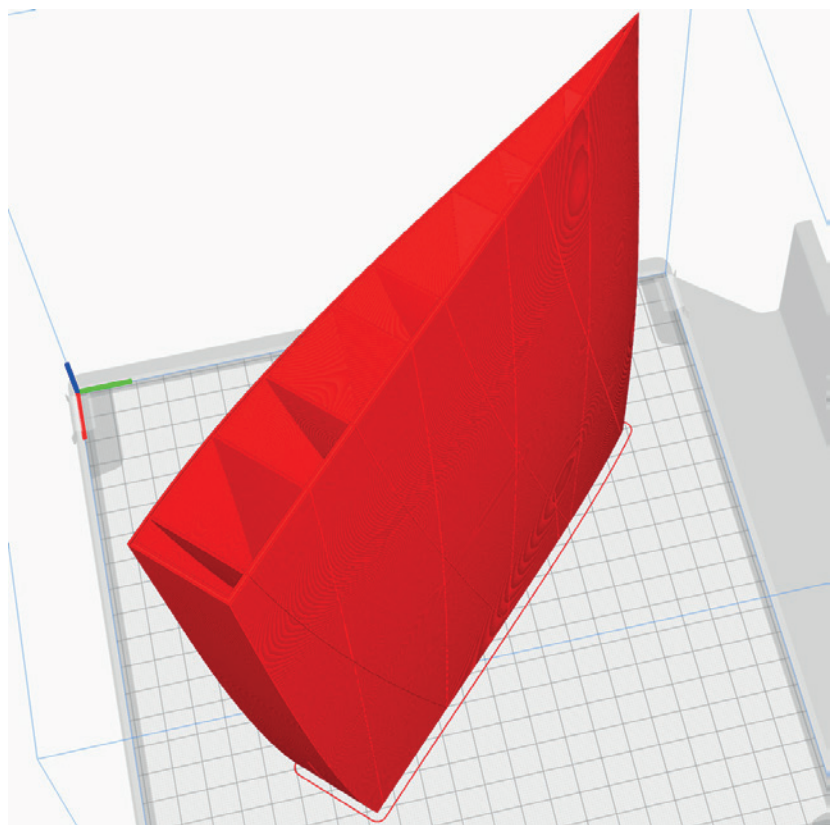

# PROFILE P3\_SURFACE Light-Weight LW-PLA

The following parts must be sliced with the PROFILE P3\_SURFACE (1-wall-print).

**Please note the additional settings for the individual parts!**

**PLEASE NOTE** In profile P3\_SURFACE, there should not be more than one STL on the buildplate at the same time, otherwise slicing errors can occur! Depending on your printer, a brim may not be required.

## eagle-Wing5\_LW-left/right-profile3.stl

**MATERIAL** LW-PLA, ~ 78 g\*

\*Display in Cura. The actual weight is then 60% of this.

### ADDITIONAL SETTINGS

- Setting Profile3\_Surface
- Flow 60 % or less
- Higher nozzle temperature

The optimal weight and sufficient strength is achieved with 60 % flow. Increase the temperature until the wall thickness is 0.4 to 0.5 mm. (We print at 235° and 60% flow).

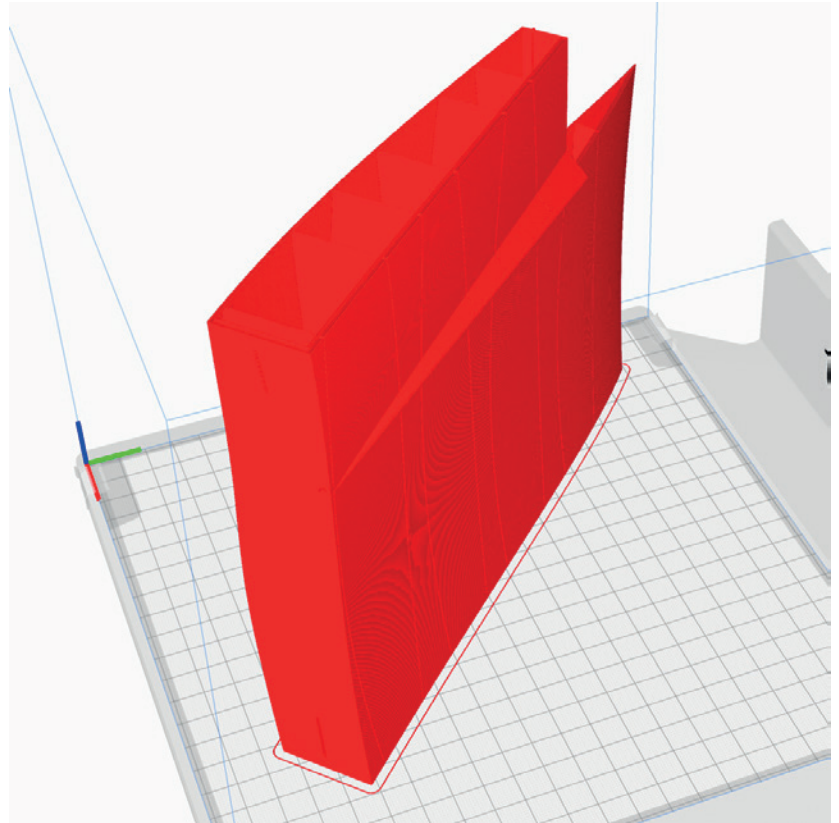

## eagle-Wing6\_LW-left/right-profile3.stl

**MATERIAL** LW-PLA, ~ 63 g\*

\*Display in Cura. The actual weight is then 60% of this.

### ADDITIONAL SETTINGS

- Setting Profile3\_Surface
- Flow 60 % or less
- Higher nozzle temperature

The optimal weight and sufficient strength is achieved with 60 % flow. Increase the temperature until the wall thickness is 0.4 to 0.5 mm. (We print at 235° and 60% flow).

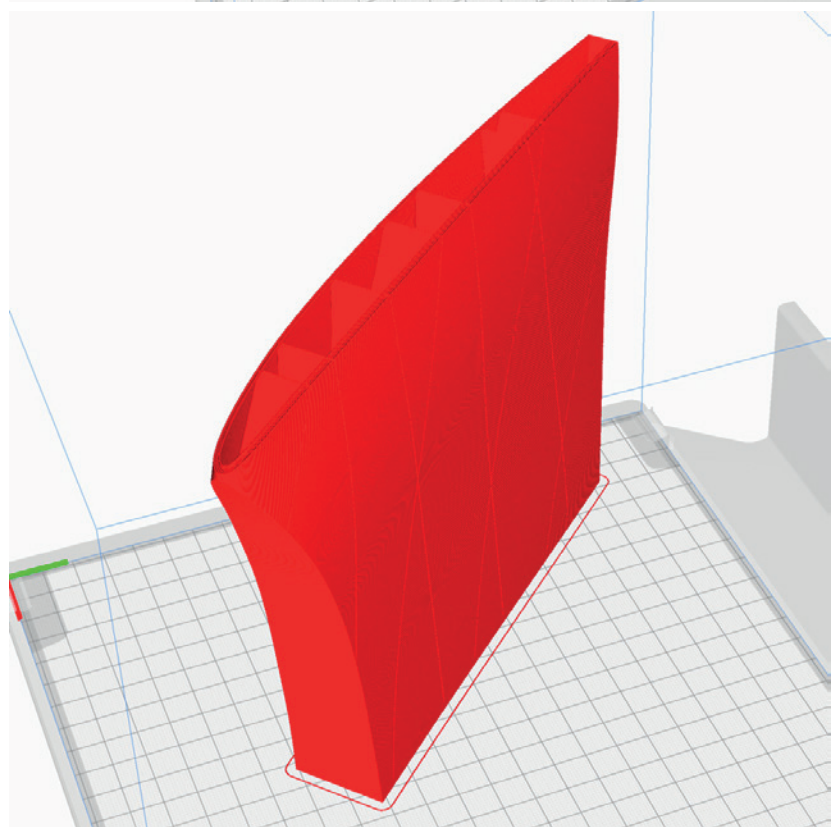

# PROFILE P3\_SURFACE Light-Weight LW-PLA

The following parts must be sliced with the PROFILE P3\_SURFACE (1-wall-print).

**Please note the additional settings for the individual parts!**

**PLEASE NOTE** In profile P3\_SURFACE, there should not be more than one STL on the buildplate at the same time, otherwise slicing errors can occur! Depending on your printer, a brim may not be required.

## eagle-Wing7\_LW-left/right-profile3.stl

**MATERIAL** LW-PLA, ~ 37 g\*

\*Display in Cura. The actual weight is then 60% of this.

### ADDITIONAL SETTINGS

- Wing7-left: Z Seam Position Back left
- Wing7-right: Z Seam Position Back right

- Setting Profile3\_Surface
- Flow 60 % or less
- Higher nozzle temperature

The optimal weight and sufficient strength is achieved with 60 % flow. Increase the temperature until the wall thickness is 0.4 to 0.5 mm. (We print at 235° and 60% flow).

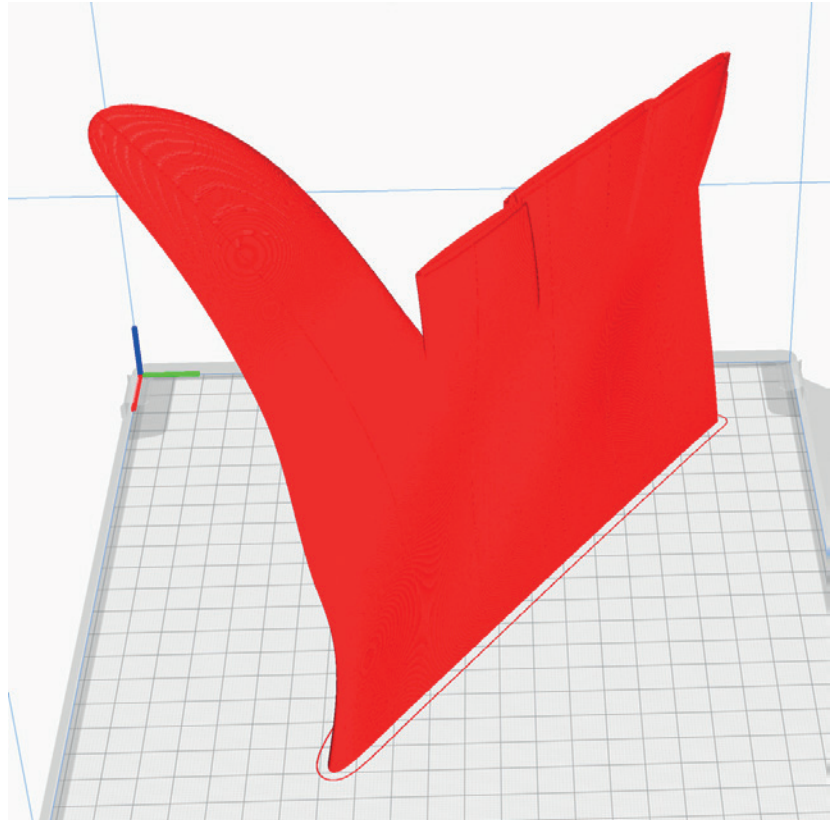

## eagle-Wing8\_LW-left/right-profile3.stl

**MATERIAL** LW-PLA, ~ 30 g\*

\*Display in Cura. The actual weight is then 60% of this.

### ADDITIONAL SETTINGS

- Setting Profile3\_Surface
- Flow 60 % or less
- Higher nozzle temperature

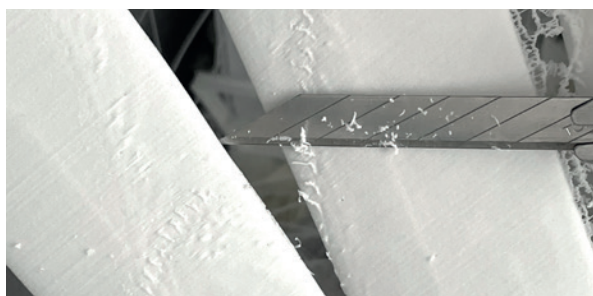
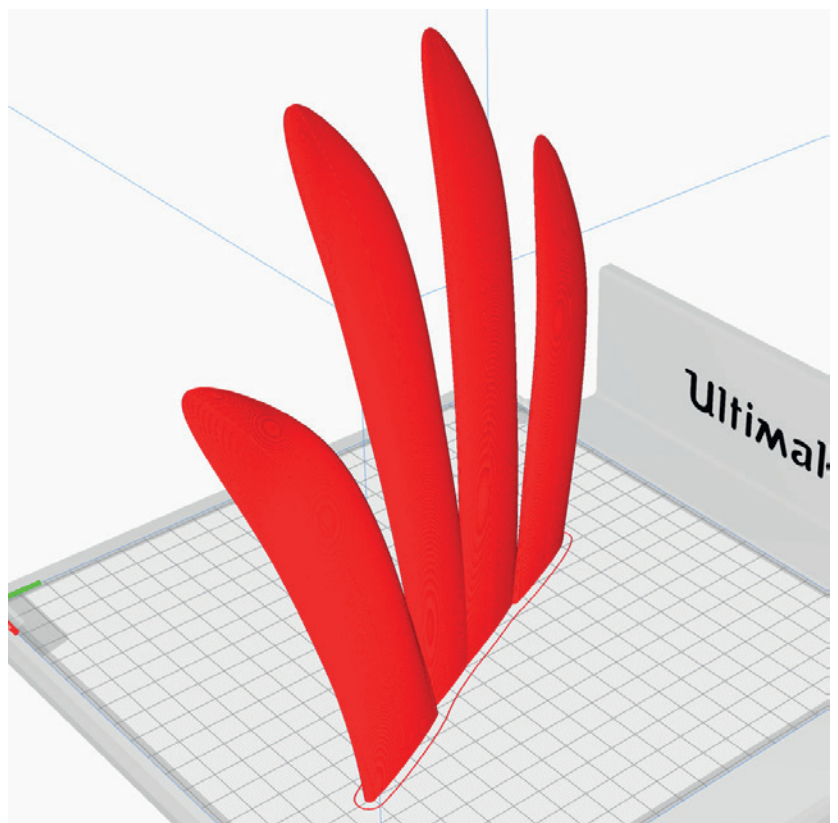

### LW PLA

Since stringing is unfortunately unavoidable when printing LW-PLA, this part have to be cleaned up with the cutter.

# PROFILE P4\_FLEX

The following parts must be sliced with the PROFILE P4\_FLEX.  
Please note the additional settings for the individual parts!

## eagle-Parts-flex-profile4.stl

**MATERIAL** TPU ~ A95, Weight: ~ 4 g

### ADDITIONAL SETTINGS

- Wall Line Count: 10

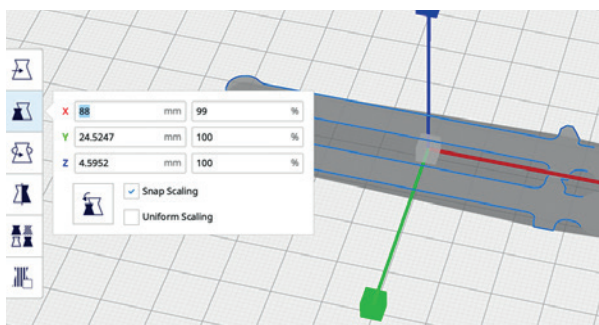

### Tension belt length

In the folder Individual parts you will find the tension belts also as a single file. If you want to change them slightly in length, you can simply change the dimension of the X-axis in Cura (Uniform scaling must NOT be selected).

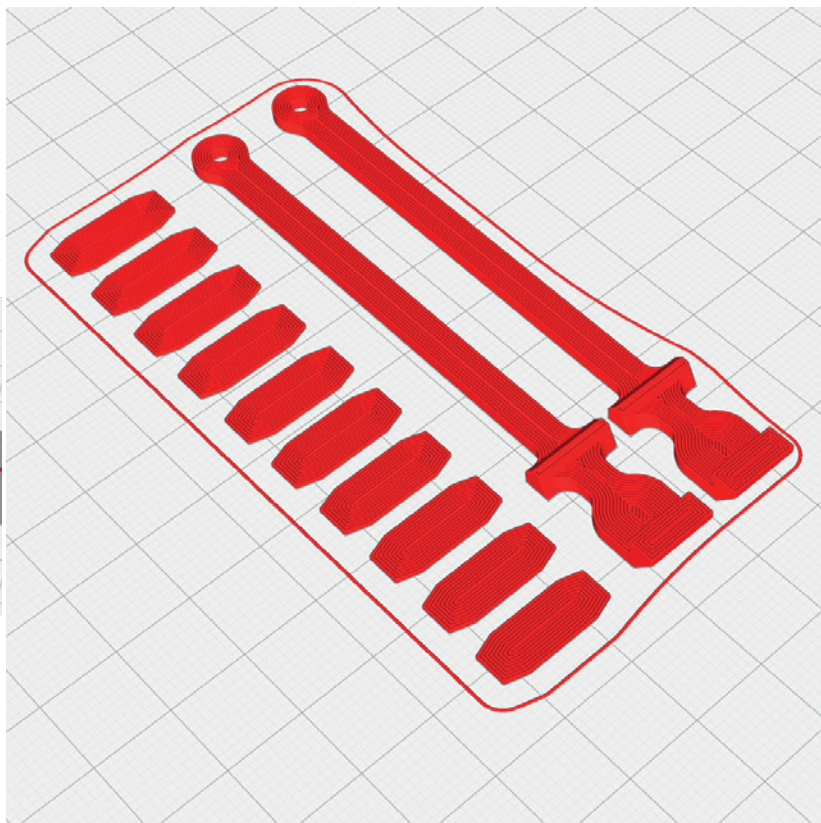



# REQUIRED ACCESSOIRES

## Filament

- normal PLA about 400 grams
- LW-PLA about 500 grams (**Absolutely necessary**)
- TPU (A95) about 10 grams

## Materials

- some tapping screws  $\text{\O}2*8$  mm  
(**simply search for: M2 flat head tapping screw assortment**) →
- CA super glue (liquid and liquid medium)
- CA activator
- Servo extension cable 300mm, 2 pieces
- Carbon tube  $\text{\O}8*1000$ mm, 1 piece
- Steel wire  $\text{\O}1$ mm
- Neodym-Super-Magnet  $5*5*5$ mm, 4 pieces
- Rod connection, 3 pieces
- Foil **0,5mm/0.020inches** Din A4 (PVC, PET-G, Polycarbonate or Lexan), 1 piece

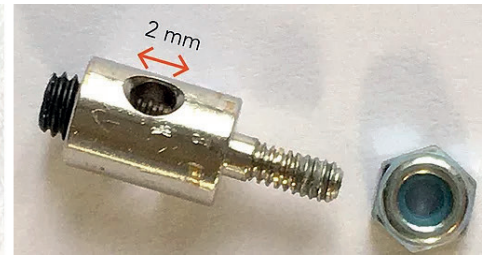

## Tools

- Cutter knife
- small Philips screwdriver
- Drill  $\text{\O}2,5$ mm,  $\text{\O}1,5$ mm

# RC Components

The Notos allows the installation of a wide variety of drives.  
We have good experience with this version:

**ENGINE** RAY G3 C2836/1120 or comparable motors

**FOLDING PROP** 11x5 (2S), 10x5 (3S) with a spinner Ø32mm or Ø30mm

**BEC-CONTROLLER** 30-50 A (must fit the engine!)

**RECEIVER** 4 Channel

**BATTERY** 2S or 3S Lipo, about 1000-2200 MaH

**SERVOS** Hitec HS-55 or EMAX ES08(A or D), 3 pieces

Pay attention to the position of the motor shaft

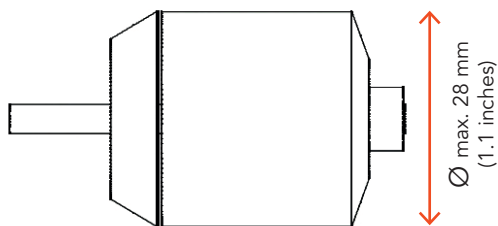
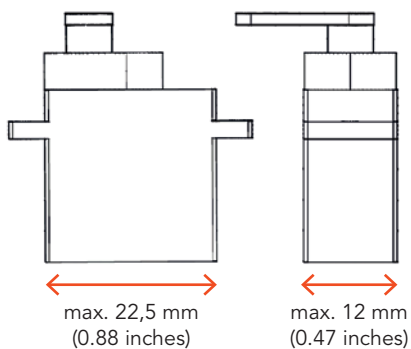
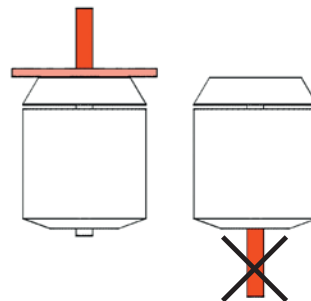

# ASSEMBLING MANUAL

## Basic information

### Gluing the parts

To glue the fuselage and wing parts well, **use medium-liquid CA** adhesive.

First check whether the parts go well together. Then apply a lot of CA glue to the part with the connections and all surfaces that will touch later (except the bowden tubes). Put the parts together and align the parts perfectly. If glue comes out, wipe with a cloth. Then spray activator spray on the glue points.

**IMPORTANT** For a strong connection, the adhesive surfaces should be sanded. Please only use fresh CA glue and activator spray for curing! The adhesive connections must hold perfectly!

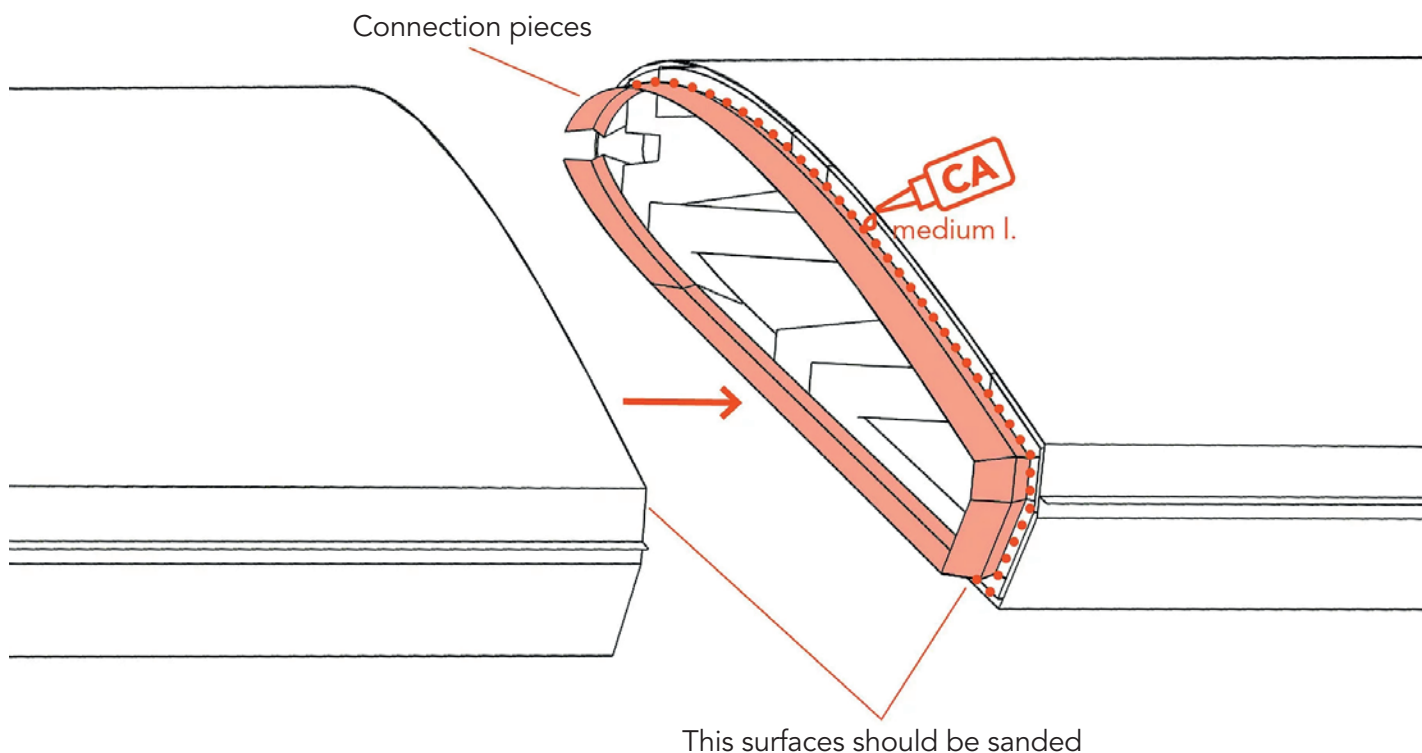

## Basic information

### Installation of the TPU hinges

First insert the hinge into the movable flap and add a drop of liquid CA adhesive into the gap. Wait for the glue to drain completely, then spray the activator on it.

Then put the flap in the wing until the flap touches the spacers and put a drop of CA glue on the hinge. Wait again for the glue to run in, and then spray the activator on it.

**Do not use too much glue, the flap must move easily!**

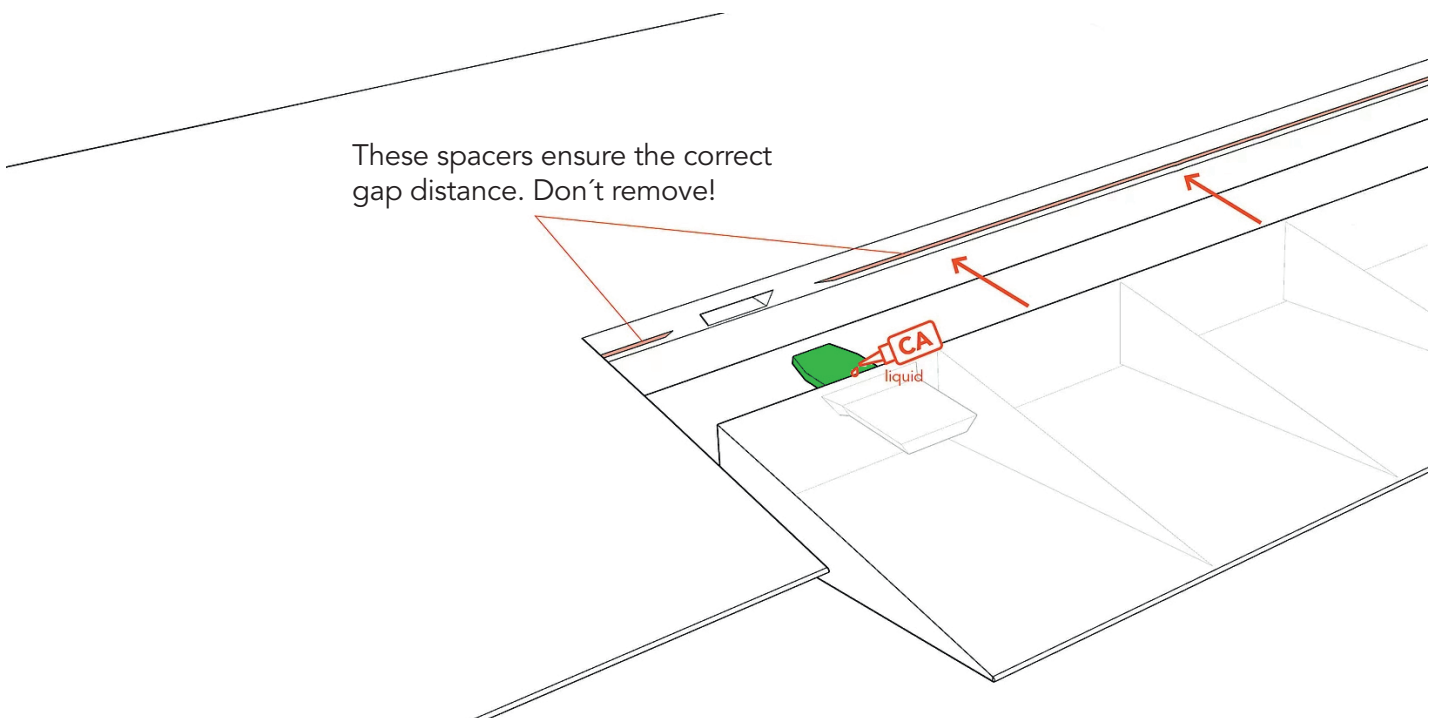

# Wings assembly 1

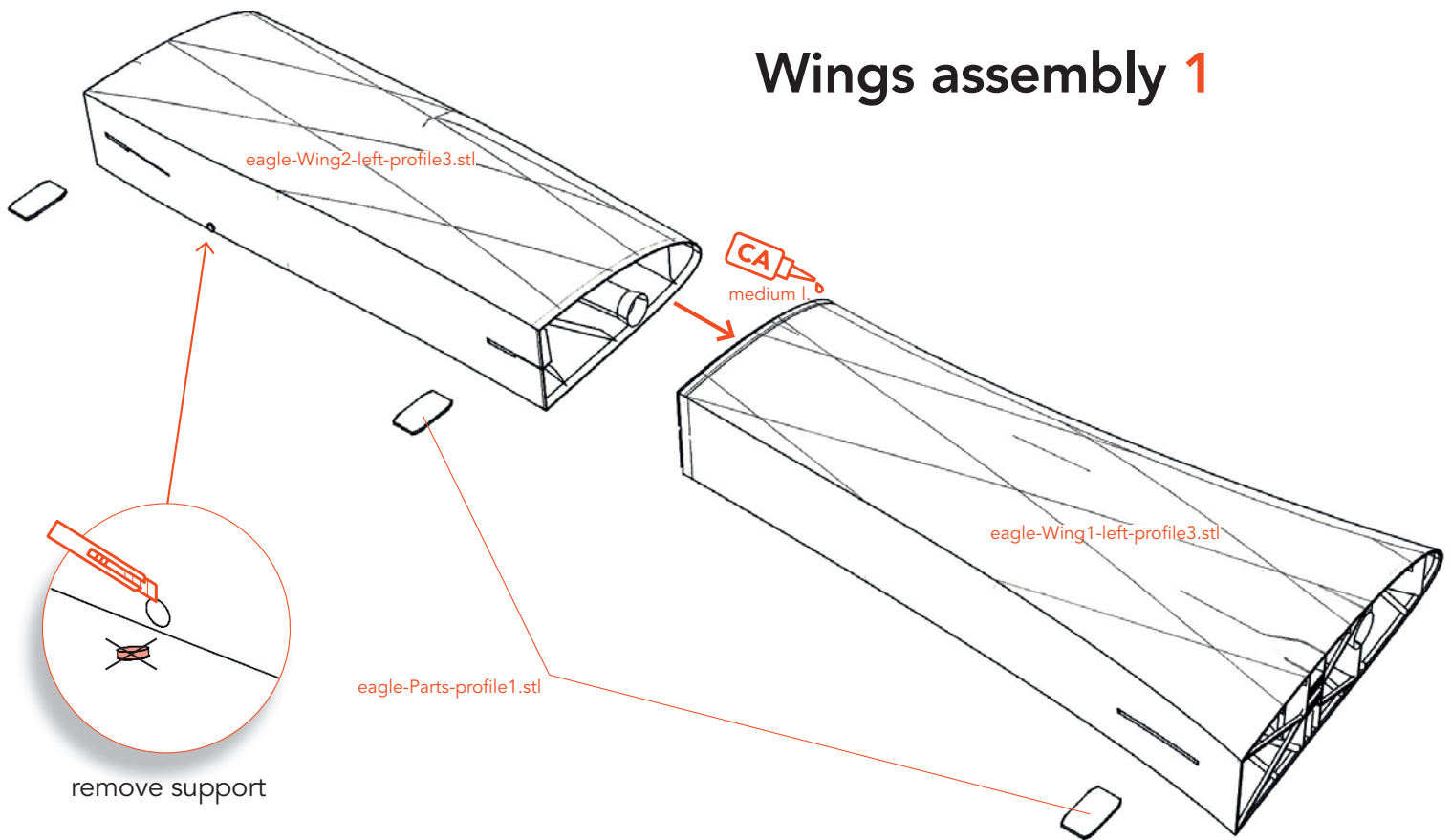

# Wings assembly 2

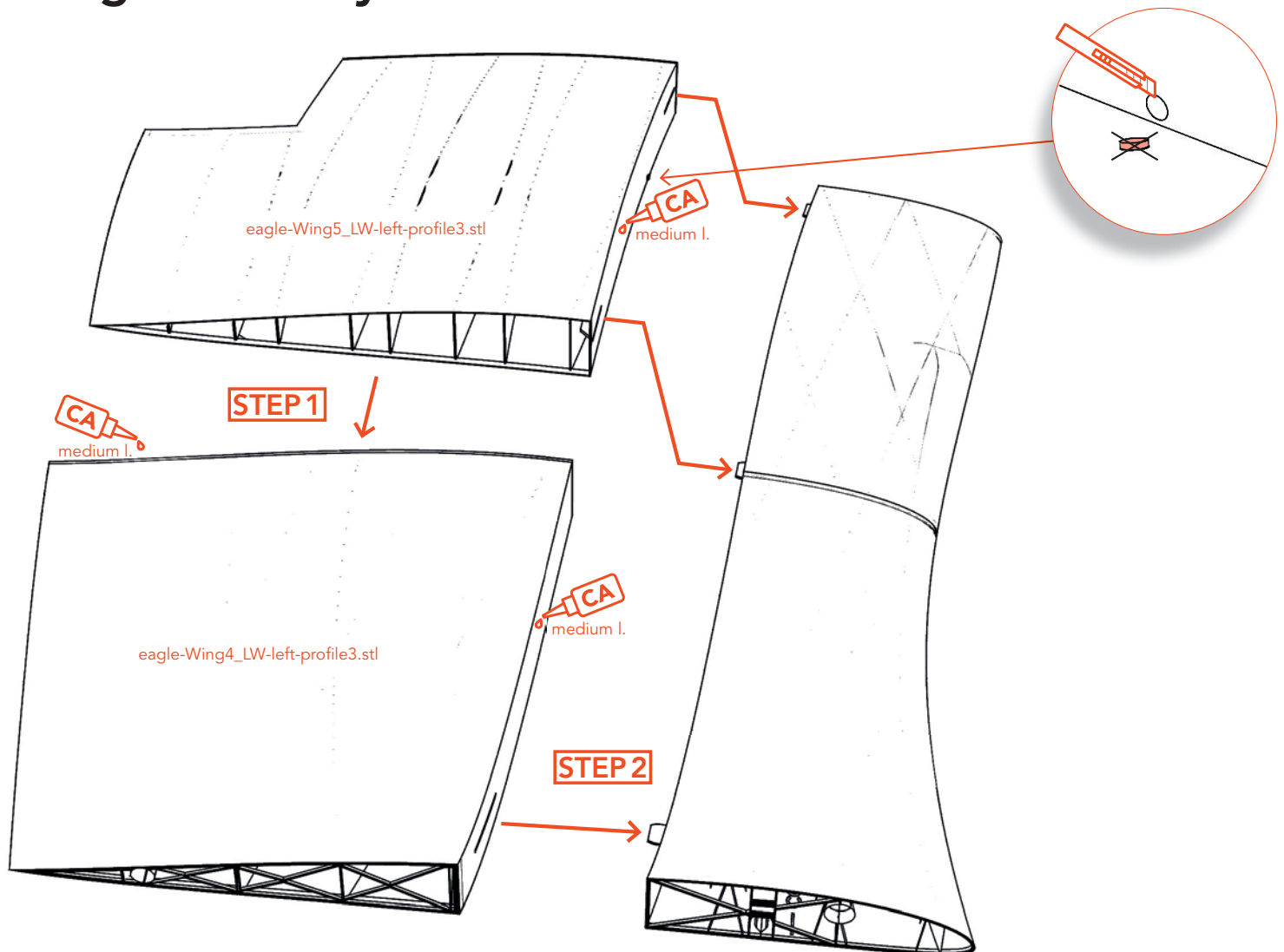

# Wings assembly 3

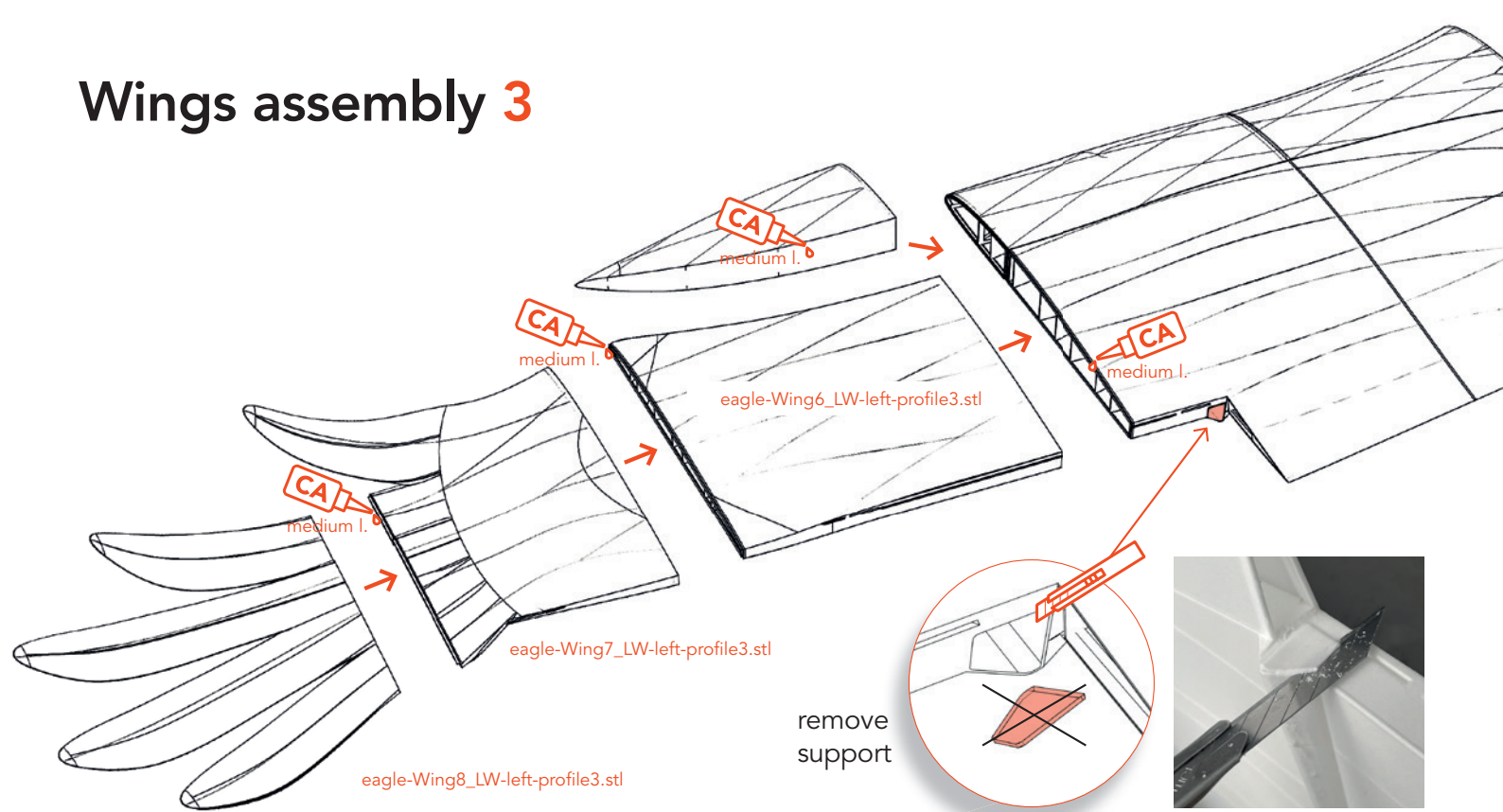

# Fuselage assembly

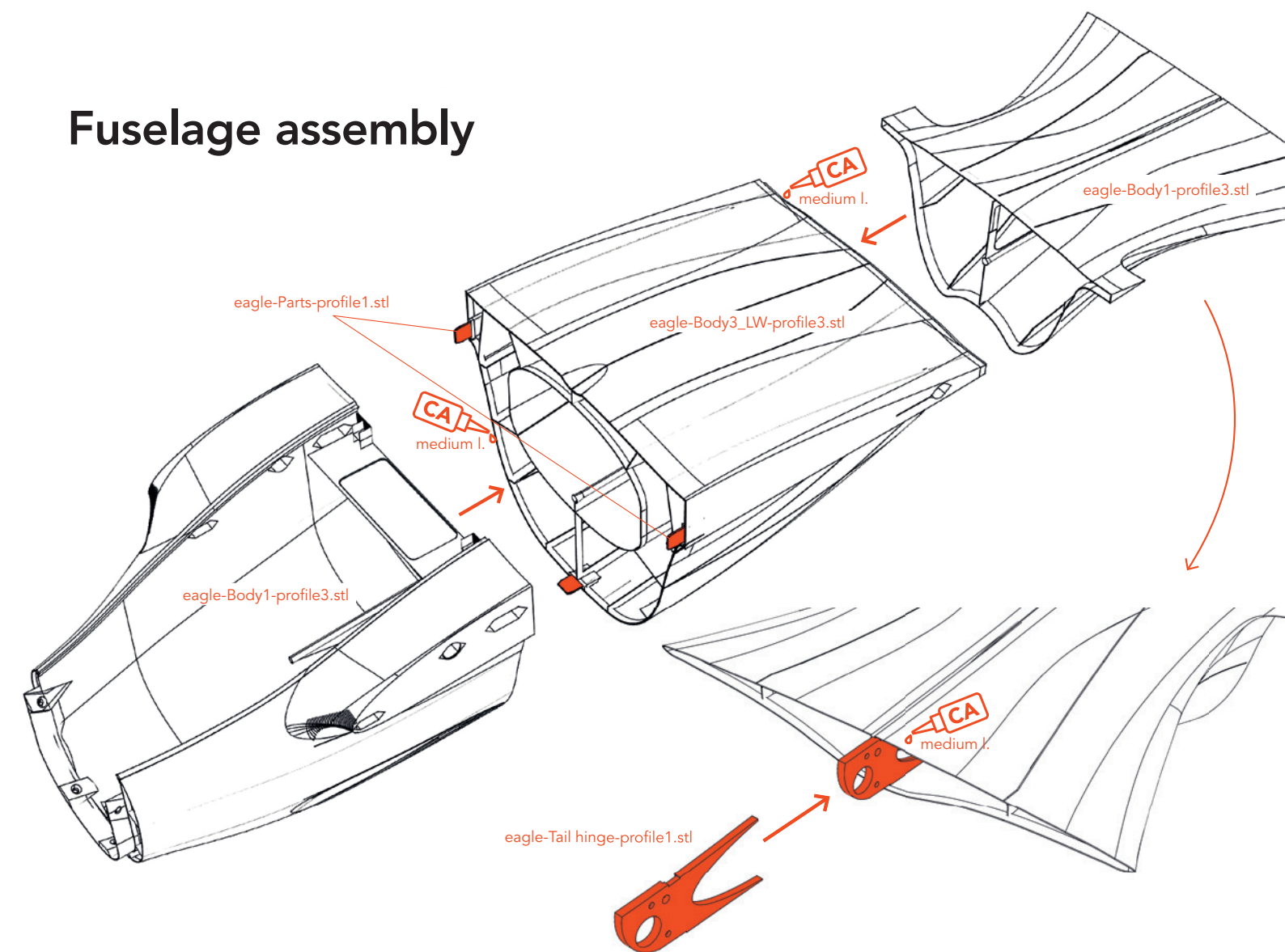

# Tailplane assembly – step 1

First check that the steel wire fits into the tail hinge and that it moves easily and accurately.

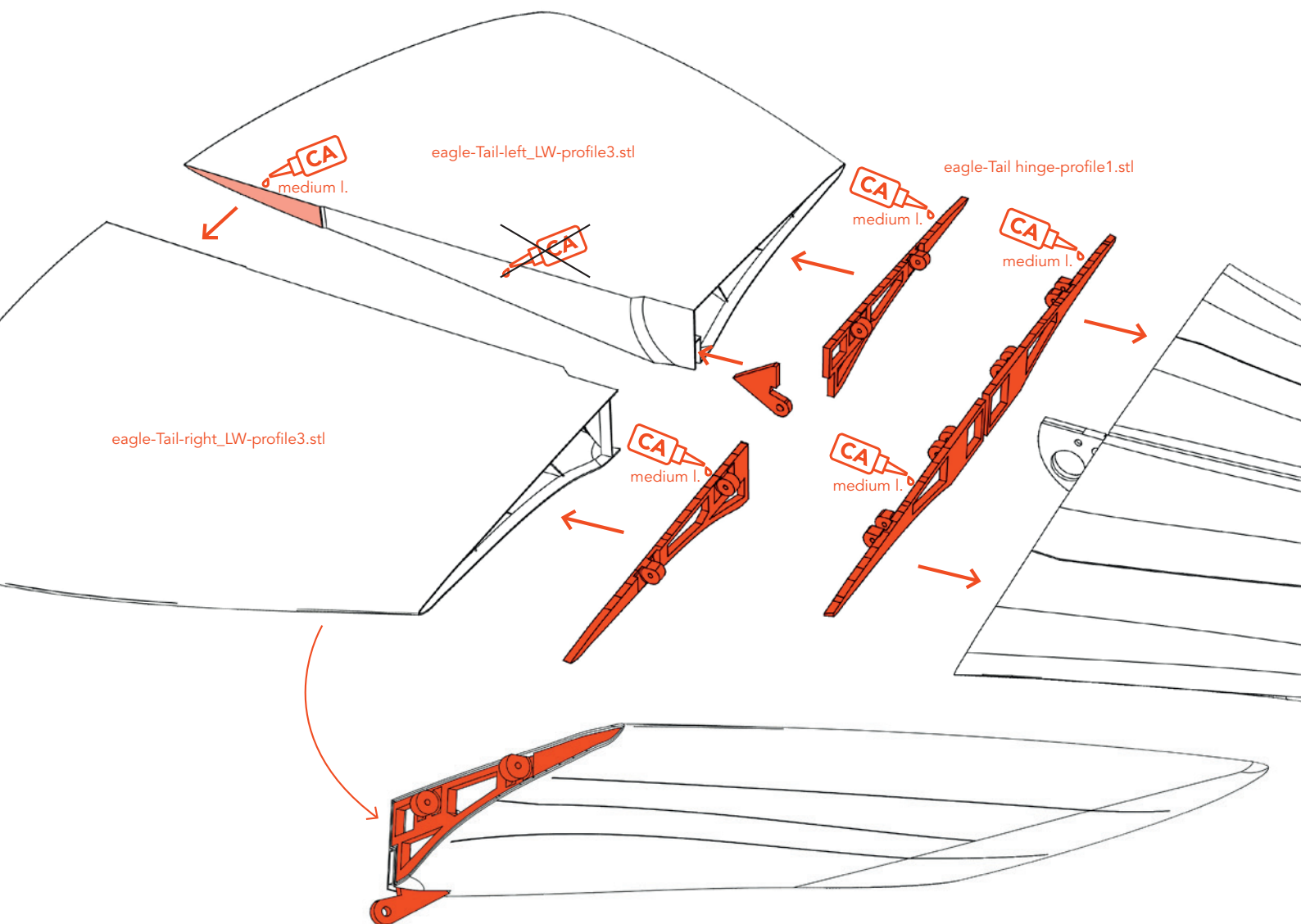
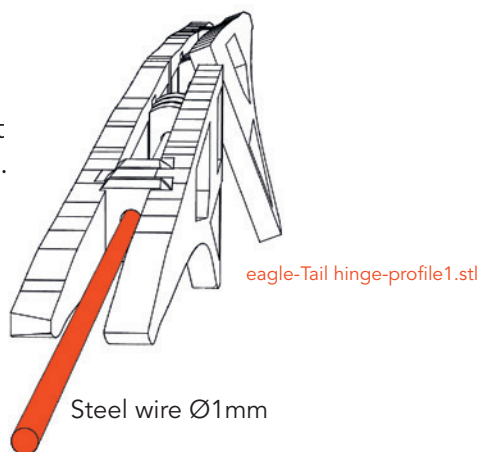

# Tailplane assembly – step 1

**IMPORTANT** The rudder is enormously important for a safe flight and must not be smaller!

First, please print the file **Rudder template.pdf** from the download folder.

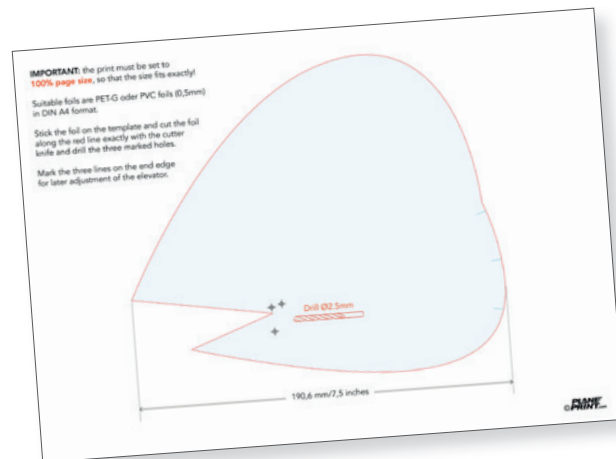

Insert the rudder into the slot of the fuselage and tighten it with two short tapping screws.

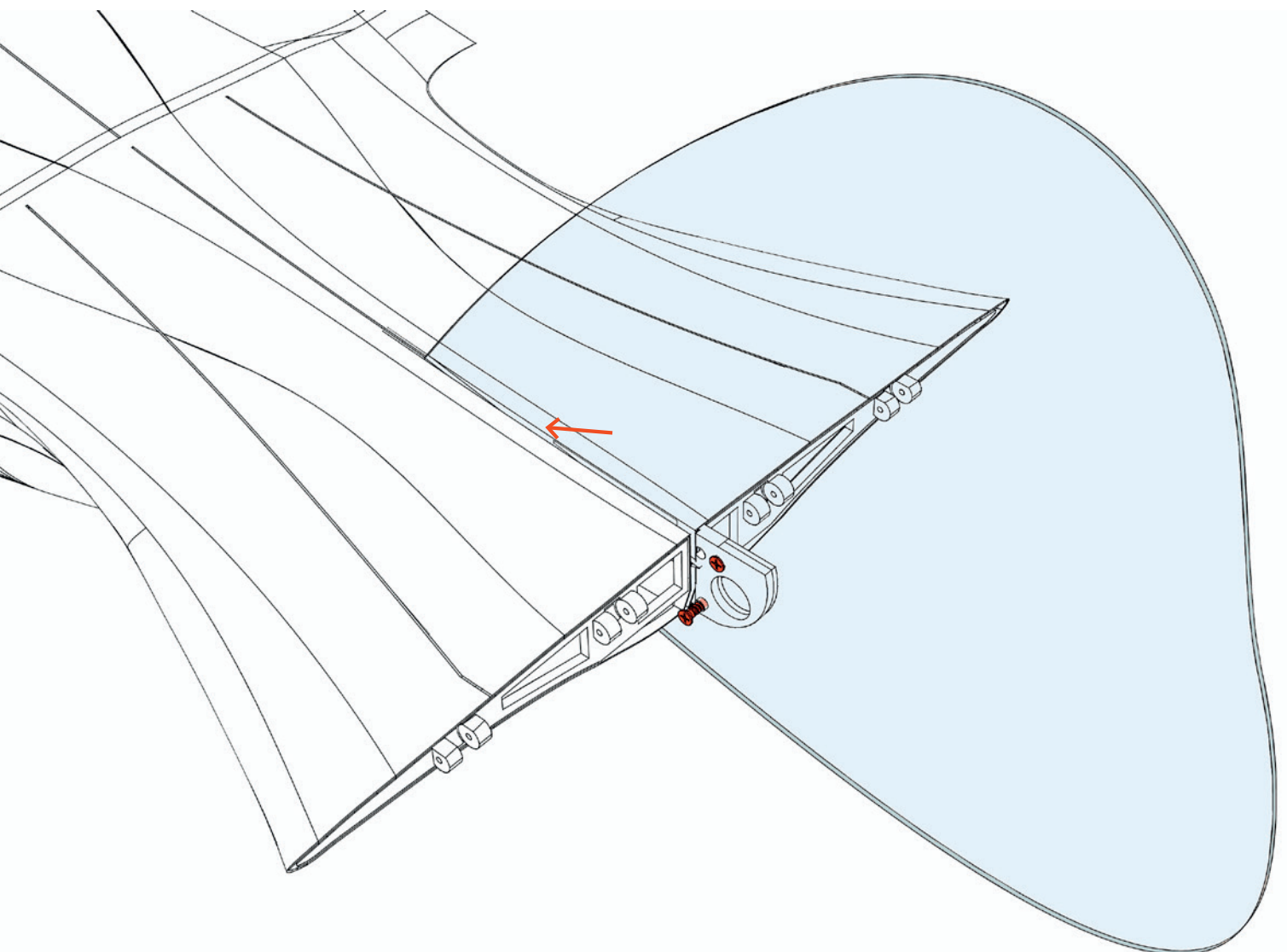



Fix the steel wire to the fuselage with a drop of CA glue.

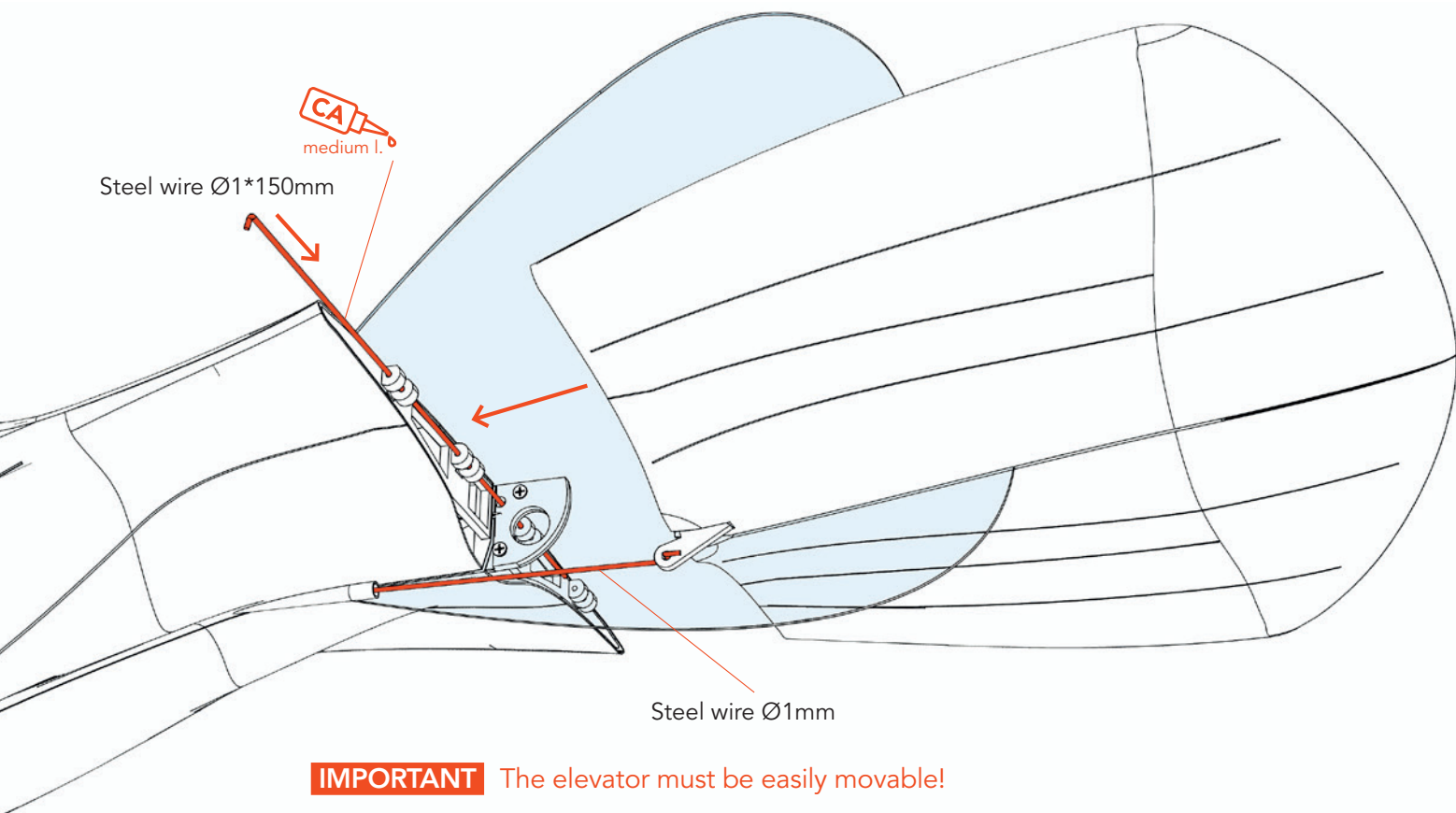

## Magnetic cover fastener

Stick the four 5\*5\*5mm neodymium magnets into the holes provided.

**IMPORTANT** Make sure that the magnets are in the correct orientation to each other and do not repel each other!

The cover is inserted into the opening at the head and fixed with the magnets at the back.

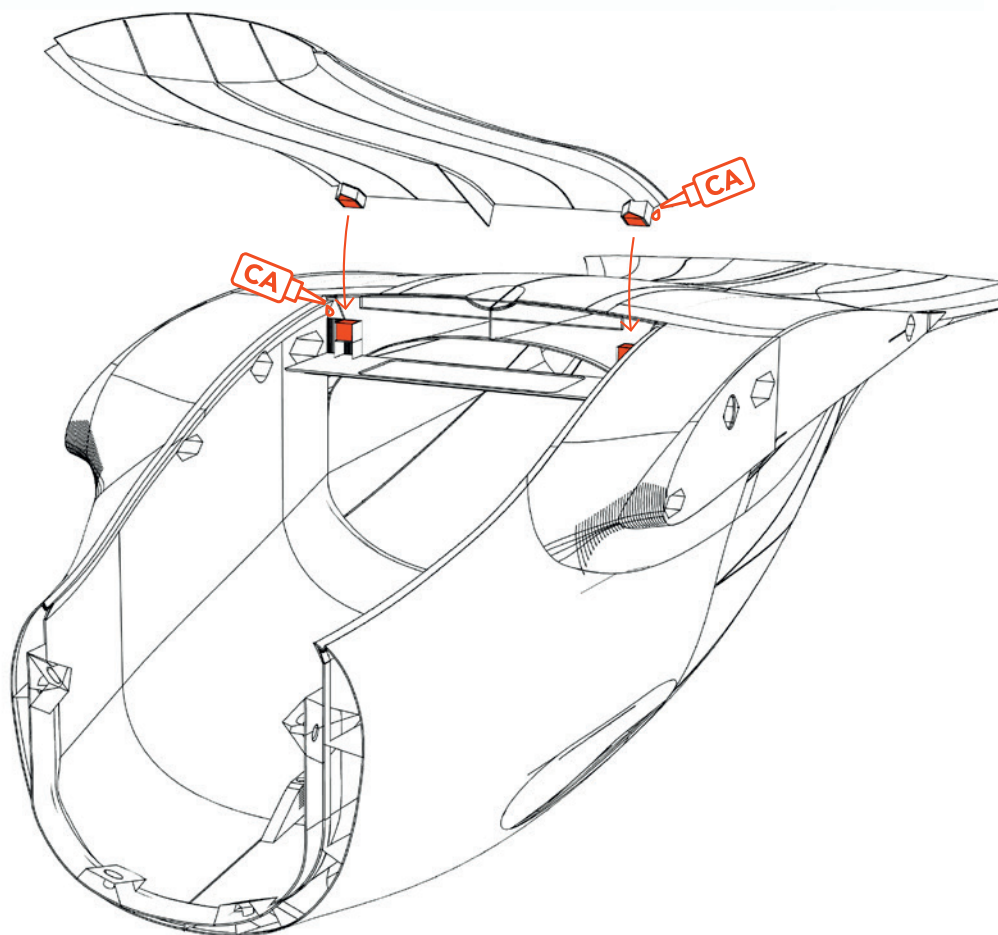

# Wing fastening

Screw the TPU tensioners into the wings, attach the wings to the fuselage and clip the tensioners into the frame.

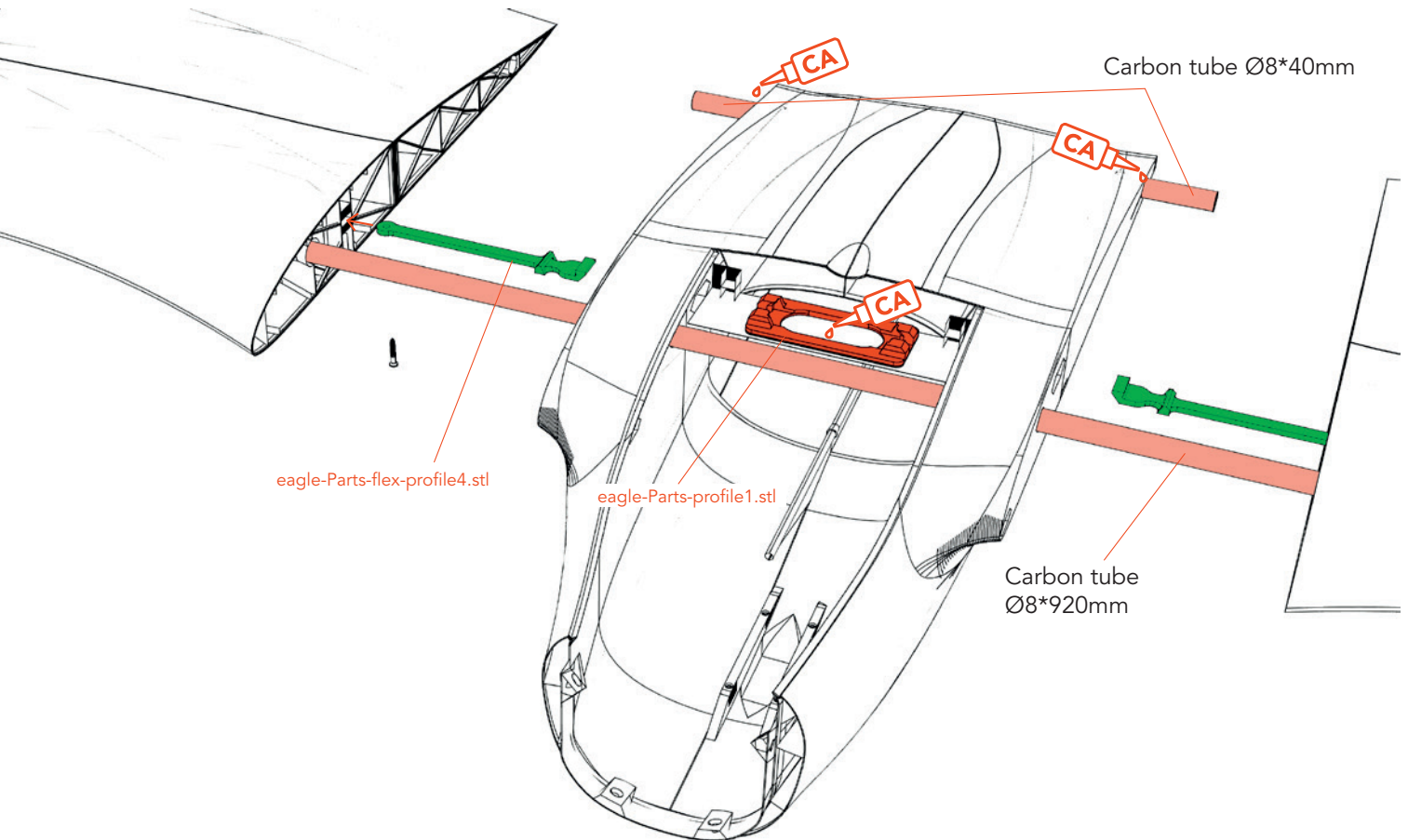
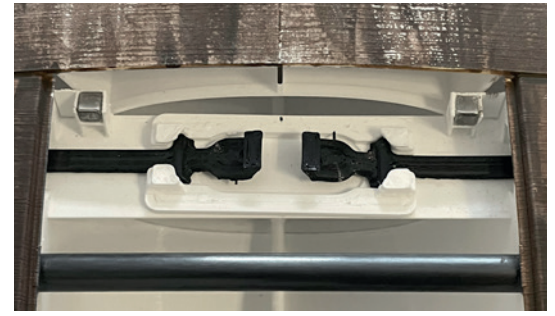

# Head attachment

The head is screwed on from the inside with four tapping screws 2\*8mm and can be exchanged for the motor head.

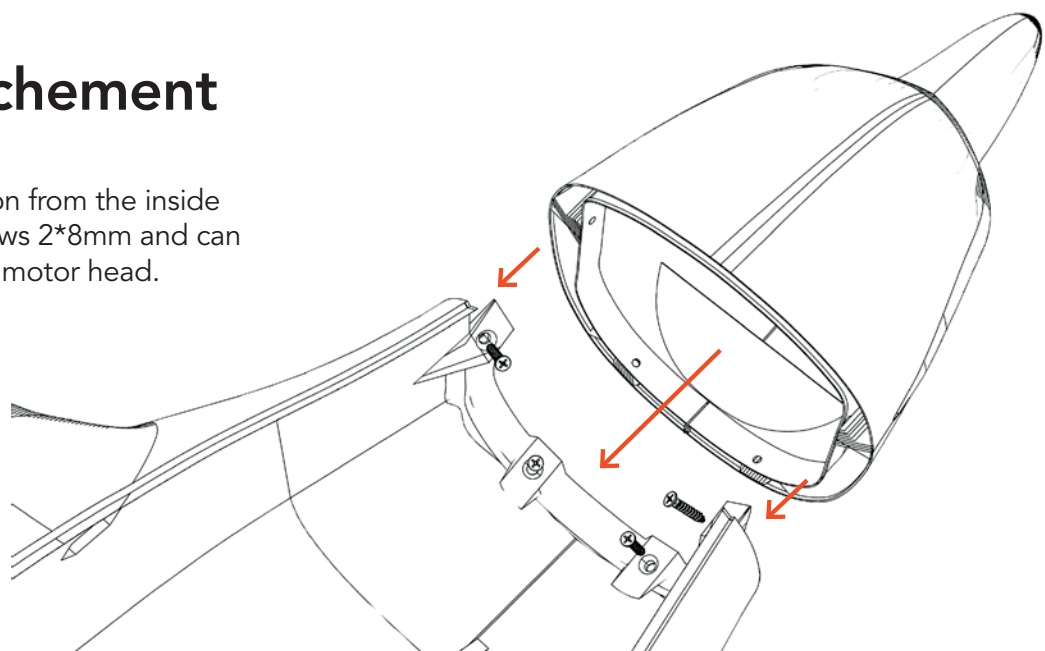

# Motor mounting

**SAFETY FIRST** Use appropriate screws for motor mounting to ensure safe operation! Make sure the prop runs smoothly and does not generate vibrations. **Check regularly that the motor mounting is absolutely tight!**

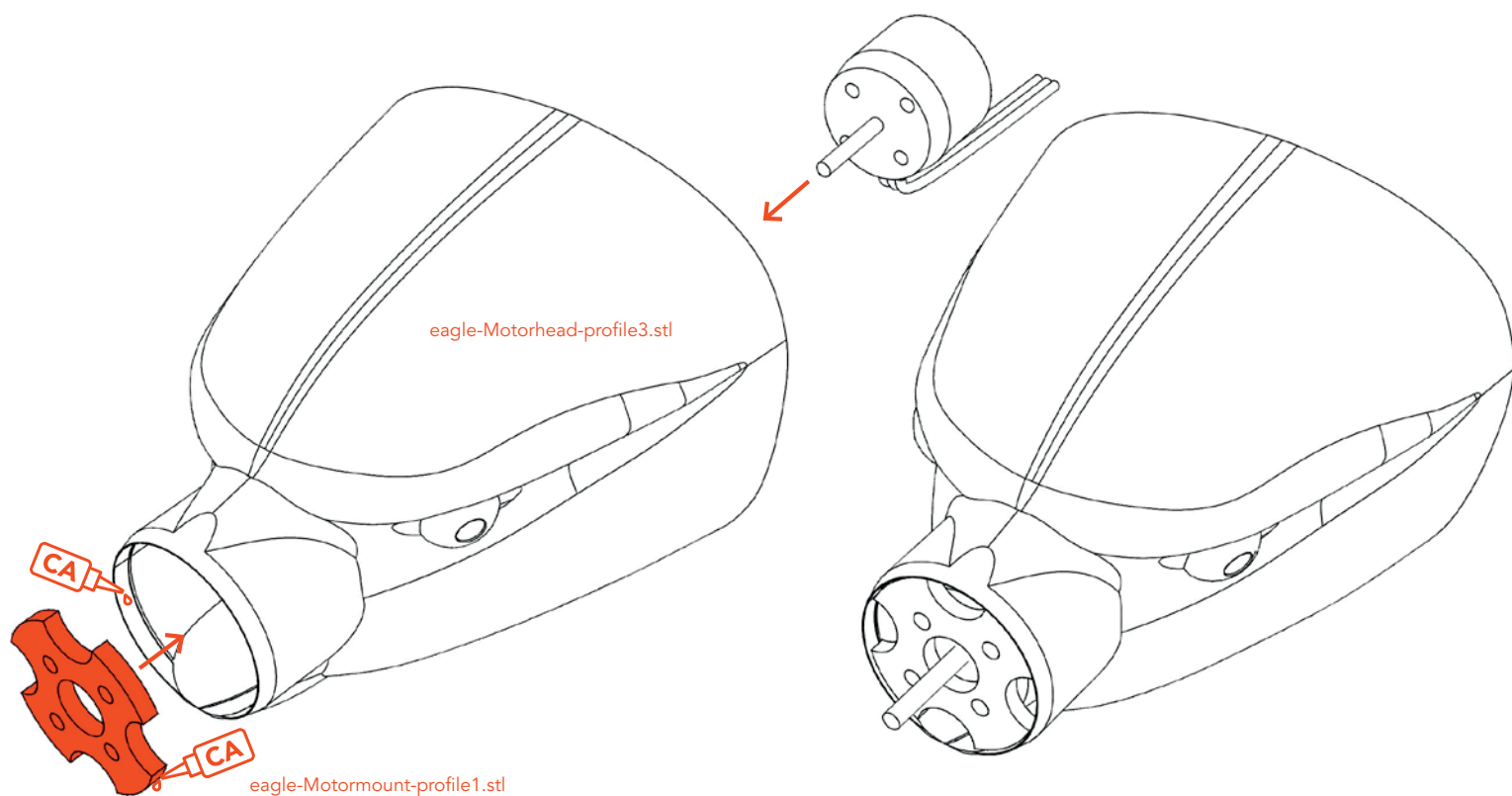

# Servo Elevator

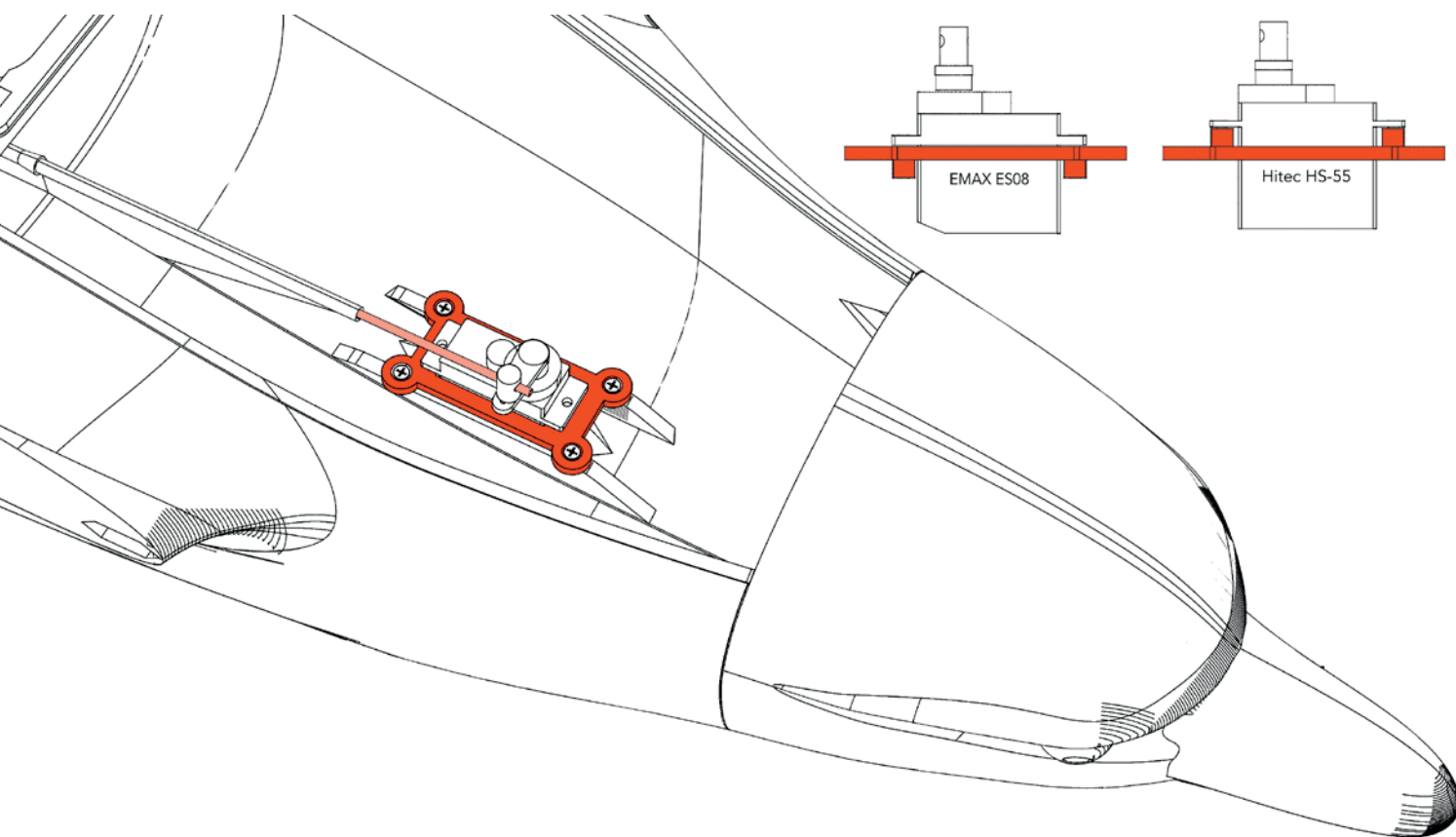

# Aileron/Servo mounting – Example left side

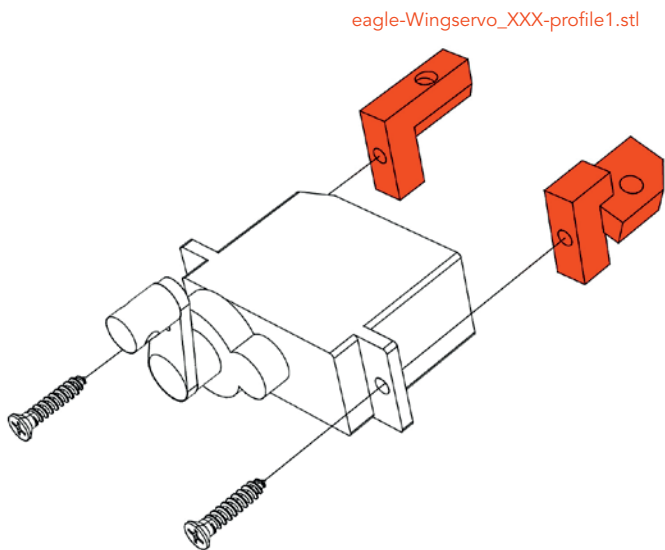
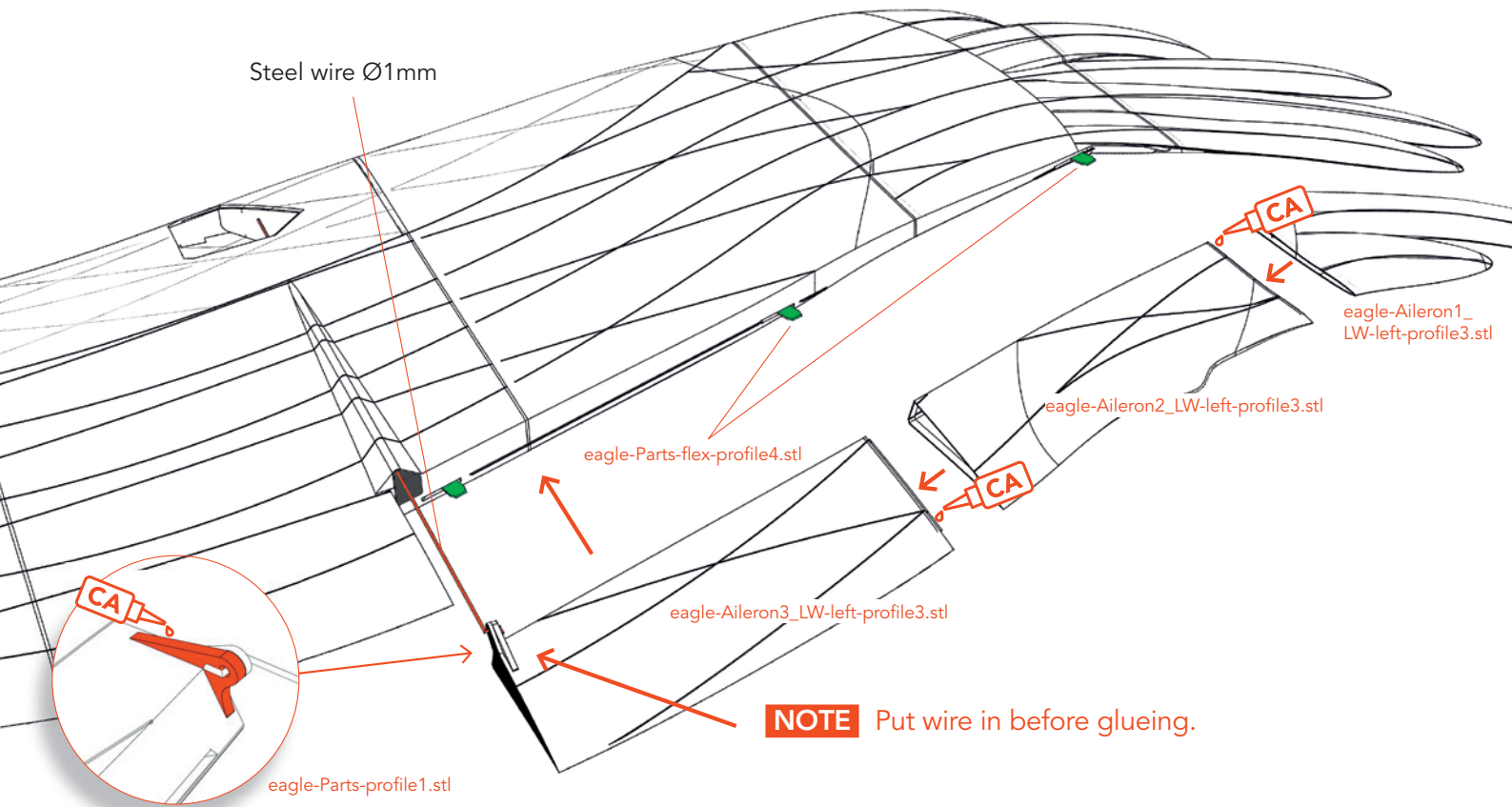

When the servo is installed, fix the cover (eagle-Servocovers-profile3.stl) with a tape.

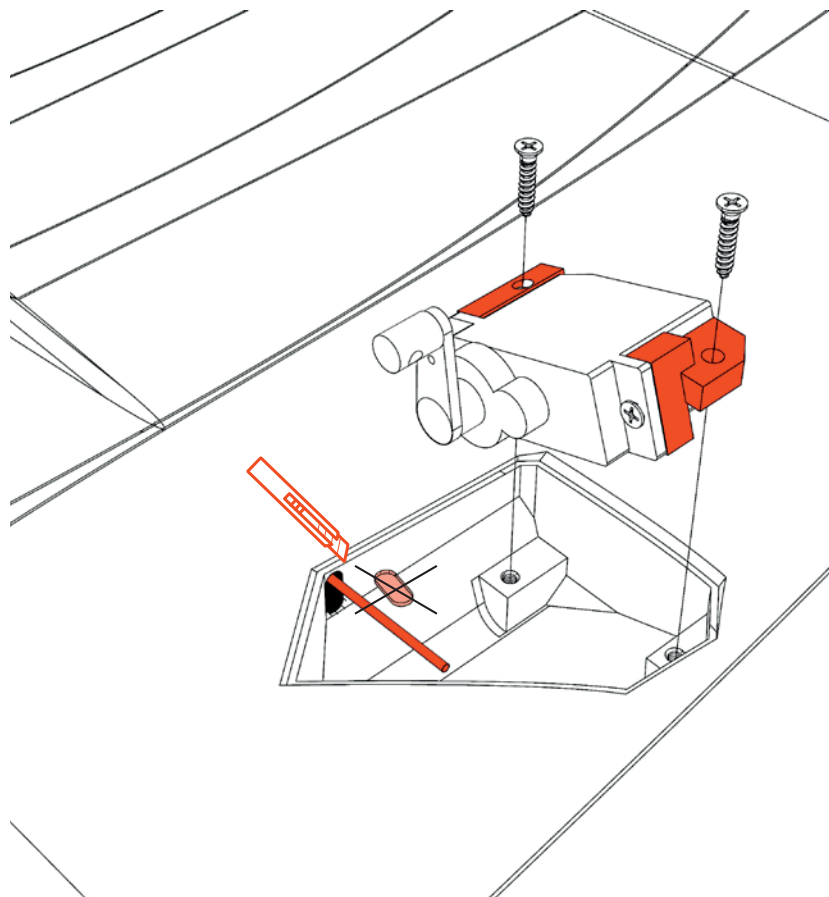

# RC components

Attach the Controller, receiver and battery with self-adhesive Velcro.

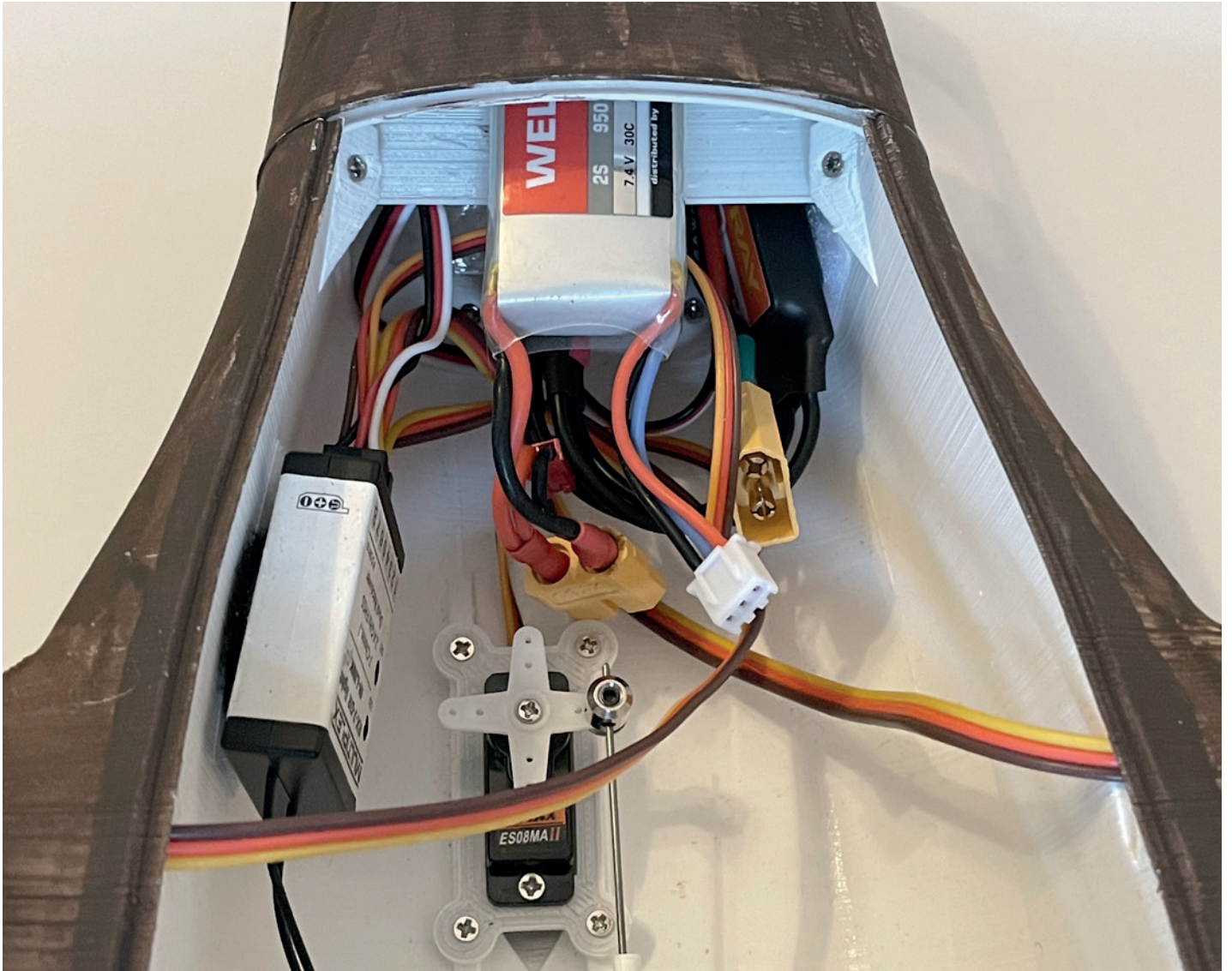

# SETTINGS FOR FLYING

After installing the electronics and setting up the transmitter, check that the control surfaces are aligned correctly. Set the transmitter trim to zero. The ailerons should be aligned with the trailing edge of the wing tip. Then align the flaps with the ailerons. The elevator should be aligned with the horizontal stabilizer and the rudder to the vertical stabilizer. Change the position of the moving parts by changing the length of the linkage from the servo arm to the control horn. In-flight adjustments can be made later with the trim.

**IMPORTANT** The eagle is programmed like a flying wing! This means that the ailerons also take over the function of the elevator. In addition, the tail must be mixed with the elevator function.

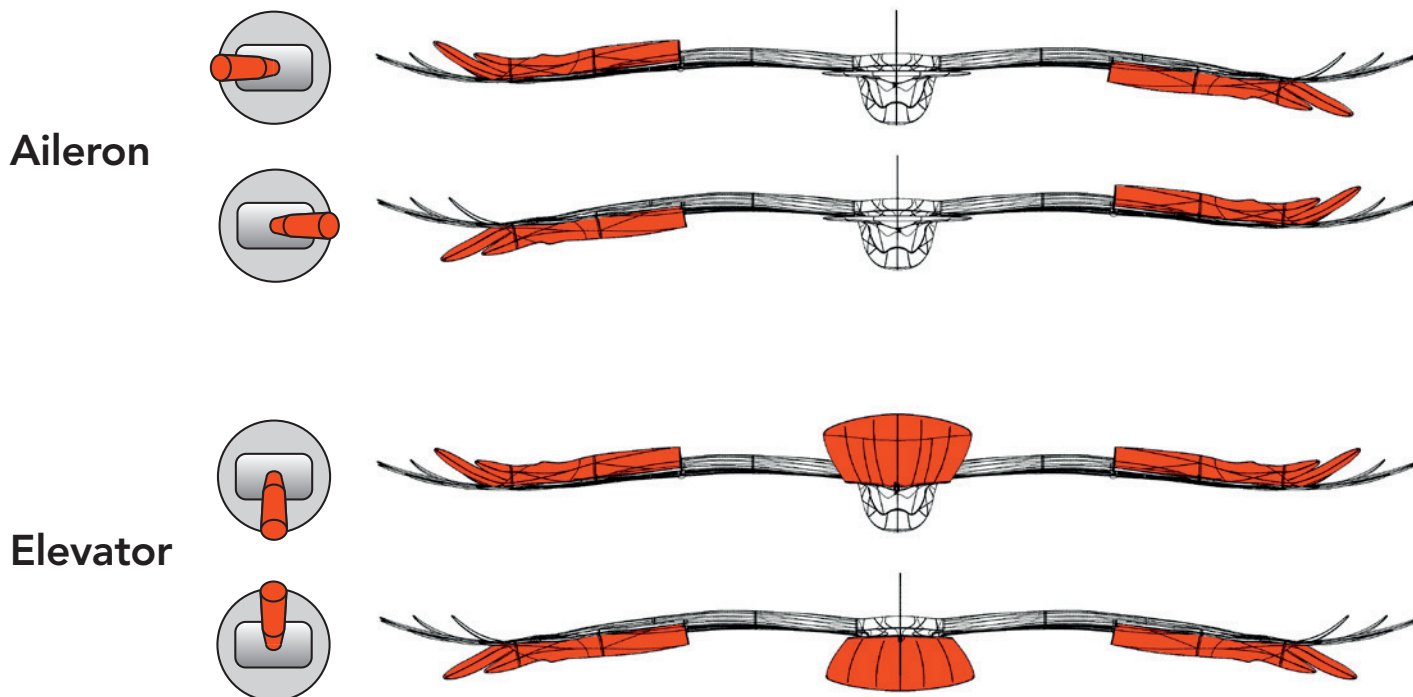

## Setting the servo travel

**AILERON** In the basic setting, the ailerons must point 2 mm upwards! up: 20 mm, down: 15 mm

**ELEVATOR** Ailerons: up 15 mm, down: 15 mm – Tail (see picture on the next page)

**MOTOR** At full throttle the elevator has to be corrected a little bit down with a mixer. Try it carefully and be prepared for the eagle to pull up at full throttle!

## Expo setting

**AILERON** 20 %

**ELEVATOR** 20 %

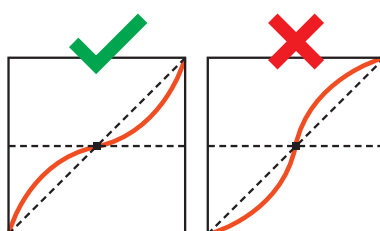

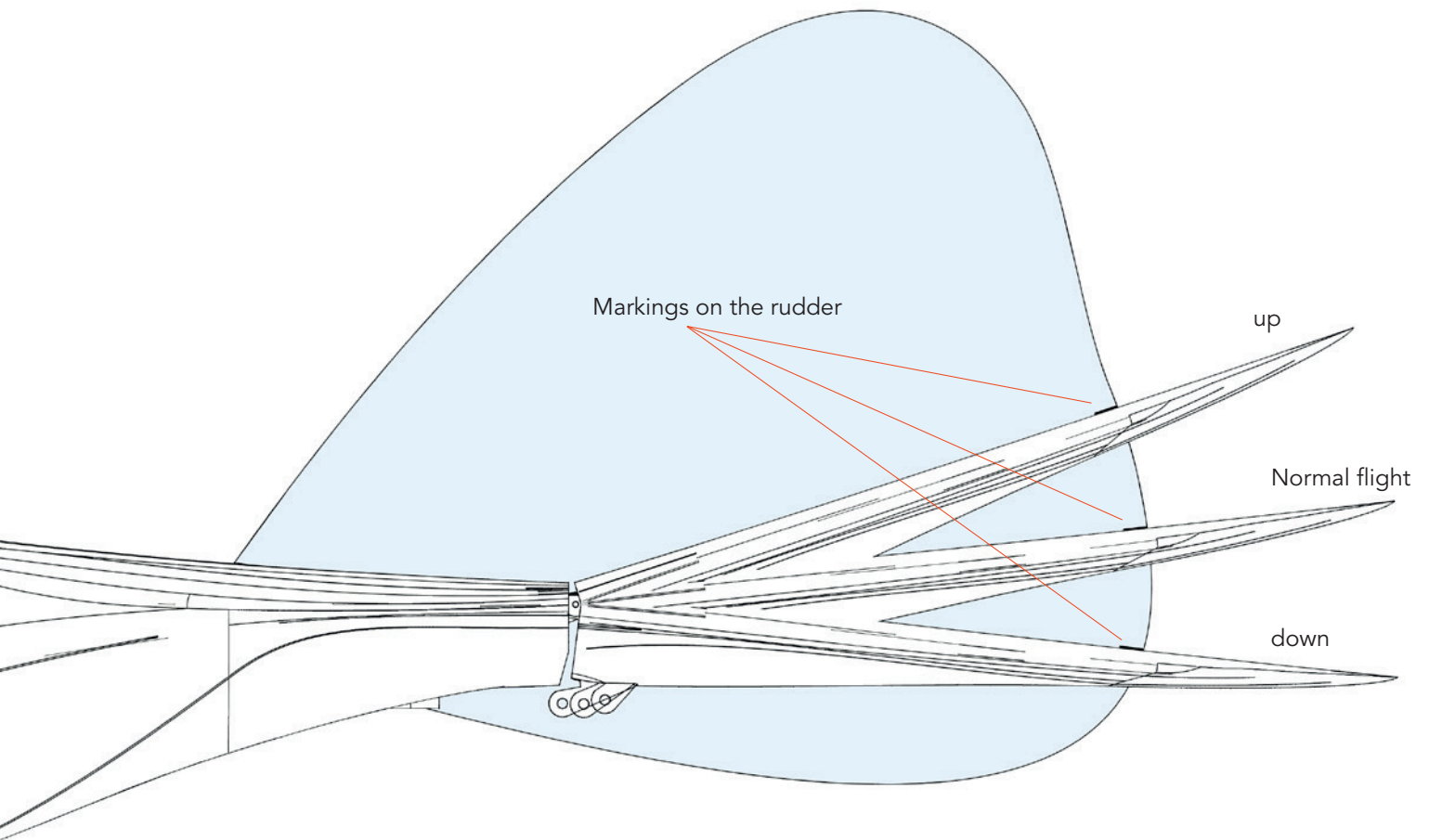

## Center of Gravity (CG)

The aircraft must balance precisely 66 mm/2.59 inches behind the leading edge (see markings on the fuselage). For the first flight we recommend to move the center of gravity about 5 mm/0.2 inches further forward.

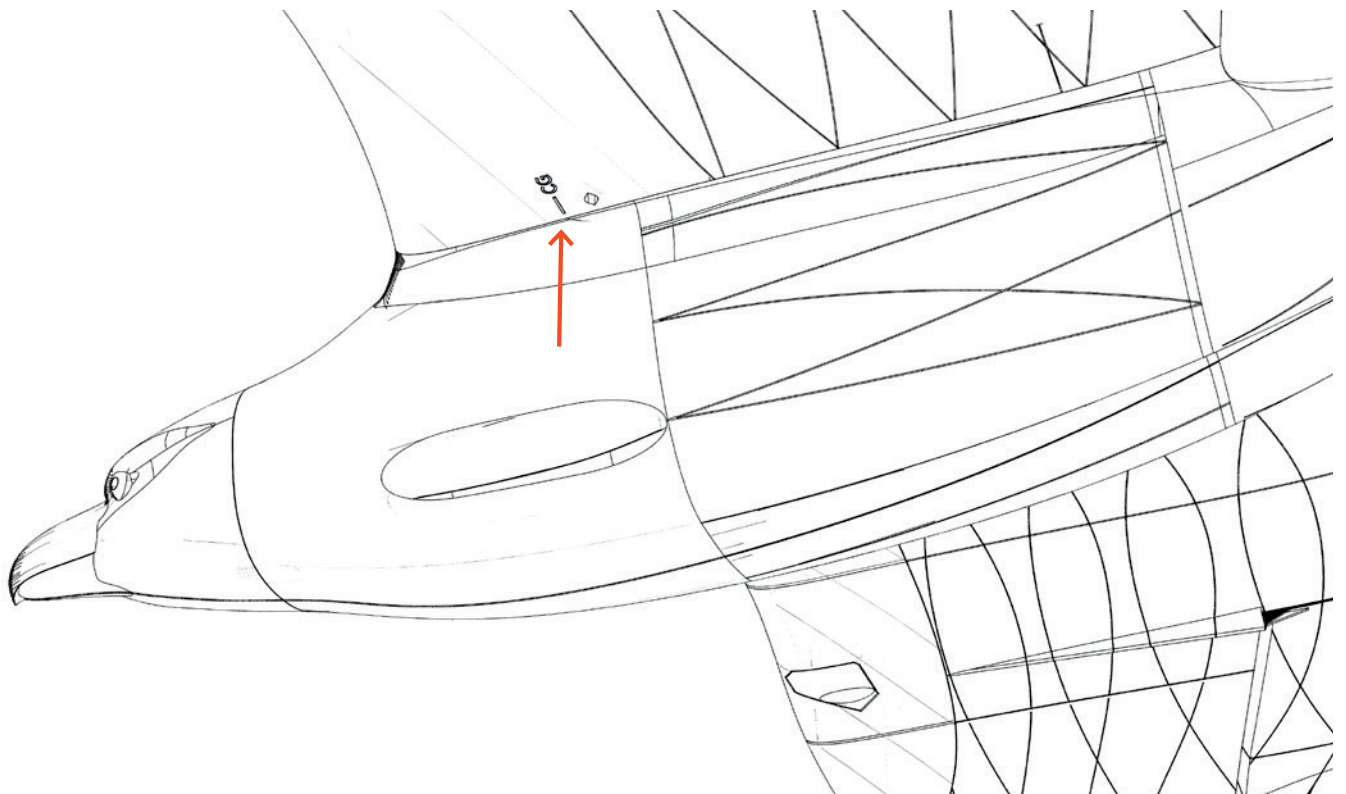

## Flight timer

Flight time will vary depending on the battery size. Expect 5 minutes under normal circumstances; however, it may be possible to fly for much longer. It is a good idea to be conservative with the flight timer until you gain experience with your airplane.

# TECHNICAL SPECIFICATIONS

**WINGSPAN** 2000 mm/78.7 inches

**LENGHT** 806 mm/31.7 inches

**FLIGHT WEIGHT** 1160 grams (Motor version)

**Please be aware of wildlife and fly the eagle only in areas where it is allowed!**



# AGE RECOMMENDATION 14+

## NOT FOR CHILDREN UNDER 14 YEARS. THIS IS NOT A TOY!

By using the download data, an RC model airplane, called „model“ for short, can be manufactured using a 3D printer. As a user of this model, only you are responsible for safe operation that does not endanger you or others, or that does not damage the model or property of others.

PLANEPRINT.com assumes no responsibility for damage to persons and property caused by pressure, transport or use of the product. Filaments, printing supplies, hardware or consumables that can not be used after faulty 3D printing will not be replaced by PLANEPRINT.com in any way.

When operating, always keep a safe distance from your model in all directions to avoid collisions and injuries.

This model is controlled by a radio signal. Radio signals can be disturbed from outside without being able to influence it. Interference can lead to a temporary loss of control.

Always operate your model on open terrains, far from cars, traffic and people.

Always follow the instructions and warnings for this product and any optional accessories (servos, receivers, motors, propellers, chargers, rechargeable batteries, etc.) carefully.

Keep all chemicals, small parts and electrical components out of the reach of children.

Avoid water contact with all components that are not specially designed and protected. Moisture damages the electronics.

Never take an item of the model or accessory in your mouth as this can lead to severe injuries or even death.

Never operate your model with low batteries in the transmitter or model.

Always keep the model in view and under control. Use only fully charged batteries.

Always keep the transmitter switched on when the model is switched on.

Always remove the battery before disassembling the model.

Keep moving parts clean and dry at all times.

Always allow the parts to cool before touching them.

Always remove the battery after use.

Make sure that the Failsafe is properly set before the flight.

Never operate the model with damaged wiring.

Never touch moving parts.

We develop our models to the best of our knowledge and belief. We accept no liability for consequential damage and injuries caused by improper use. **Please be careful when handling motors, batteries and propellers** and only move your model with insurance and in approved places!

**PLANE  
PRINT.com**

*very light 3d printable rc planes*